

# IKA

designed for scientists

**PT wireless**

ENGLISH

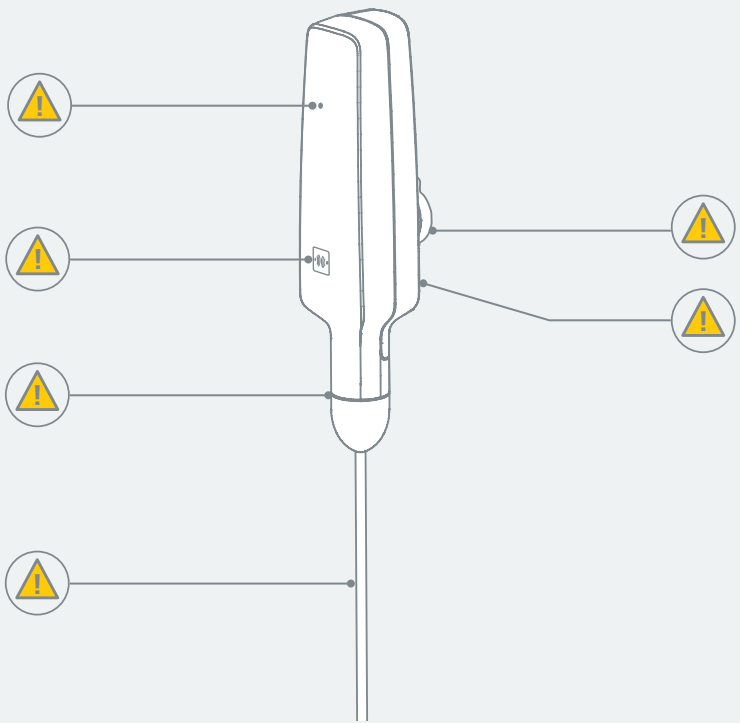











Fig. 1

	EU Declaration of conformity .....	6
	Note for USA (FCC) .....	6
	Note for Canada (IC) .....	6
	Explication of warning symbols .....	7
	Safety instructions .....	8
	Intended use .....	10
	Unpacking .....	11
	Operator panel and display .....	12
	Installation .....	13
	Operation .....	14
	Interfaces and outputs .....	16
	Maintenance and cleaning .....	18
	Accessories .....	19
	Technical Data .....	20
	Warranty .....	21



## EU Declaration of conformity

We declare under our sole responsibility that this product corresponds to the directives 2014/35/EU, 2014/30/EU and 2011/65/EU and conforms with the following standards or normative documents: EN 61010-1, EN 61326-1, EN 60529 and EN ISO 12100.

Wireless module:

Directive: 2014/53/EU

Standards: EN 60950-1, EN 300328, EN 301489-1, EN 301489-17

A copy of the complete Declaration of Conformity or further declarations of conformity can be requested at [sales@ika.com](mailto:sales@ika.com).



## Note for USA (FCC)

This equipment complies with Part 15 of the FCC rules. Any changes or modifications not expressly approved by the Manufacturer could void the user's authority to operate the equipment. This device complies with Part 15 of the FCC rules subject to the following two conditions:

- (1) This device may not cause harmful interference, and
- (2) This device must accept all interference received, including interference that may cause undesired operation.

### NOTE:

This equipment has been tested and found to comply with the limits for a Class B digital device, pursuant to part 15 of the FCC Rules.

These limits are designed to provide reasonable protection against harmful interference when the equipment is operated in a commercial environment.

This equipment generates, uses, and can radiate radio frequency energy and, if not installed and used in accordance with the instruction manual, may cause harmful interference to radio communications. Operation of this equipment in a residential area is likely to cause harmful interference in which case the user will be required to correct the interference at his own expense.



## Note for Canada (IC)

This device complies with Industry Canada license-exempt RSS standard(s). Operation is subject to the following two conditions:





- (1) This device may not cause interference
- (2) This device must accept any interference, including interference that may cause undesired operation of the device.

This device complies with Health Canada's Safety Code 6 / IC RSS-210. The installer of this device should ensure that RF radiation is not emitted in excess of the Health Canada's requirement.





## Explication of warning symbols



### /// Warning symbols

-  **Danger!** Indicates an (extremely) hazardous situation, which, if not avoided, will result in death, serious injury.
-  **Warning!** Indicates a hazardous situation, which, if not avoided, can result in death, serious injury.
-  **Caution!** Indicates a potentially hazardous situation, which, if not avoided, can result in injury.
-  **Notice!** Indicates practices which, if not avoided, can result in equipment damage.
-  **Danger!** Indicates the exposure to a hot surface.

### /// General Symbols

-  **A** Position number  
Indicates device components relevant to actions.
-  **✓** Correct / result  
Indicates the correct execution or the result of an action step.
-  **✗** Wrong  
Indicates the incorrect execution of an action step.
-  **👁** Note  
Indicates steps of actions that require particular attention.
-  **👂** Beep  
Indicates action steps, for which beep sounds are to be heard.



## Safety instructions

### /// General information

- › **Read the operating instructions in its entirety before using the device and follow the safety instructions. If this accessory is used with another device, observe also its operating instructions.**
- › Keep the operating instructions in a place where it can be accessed by everyone.
- › Ensure that only trained staff work with the device.
- › Follow the safety instructions, guidelines, occupational health and safety and accident prevention regulations.
- › The device must only be used in a technically perfect condition.

#### **Notice!**

- › Pay attention to the marked sites in **Fig. 1**.

### /// Device design

#### **Notice!**

- › The tip of the temperature sensor must be immersed at least 20 mm deep into the medium.
- › The stainless steel temperature sensor must not be used with aggressive media such as acids, caustic solutions or distilled water, due to the risk of corrosion. The H 66 glass sensor should be used in such cases.
- › Only use glass encapsulated temperature sensors for electrolysis procedures.
- › Always use the extension cable H 70 when the media being processed produces vapour. This ensures that the control unit does not come into contact with the vapour.

### /// Working with the device

#### **Danger!**

- › Do not use the device in explosive atmospheres, it is not EX-protected.
- › With substances capable of forming an explosive mixture, appropriate safety measures must be applied, e.g. working under a fume hood.
- › To avoid body injury and property damage, observe the relevant safety and accident prevention measures when processing hazardous materials.

#### **Danger!**

- › Exercise caution when touching the temperature sensor!
- › The temperature sensor can reach dangerous temperatures. Pay attention to the residual heat on the temperature sensor after removing from the media.

#### **Warning!**

- › Only process media that will not react dangerously to the extra energy produced through processing. This also applies to any extra energy produced in other ways, e.g. through light irradiation.
- › Beware of hazards due to:
  - flammable materials,
  - combustible media with a low boiling temperature.
- › Process pathogenic materials only in closed vessels under a suitable fume hood.

- › The safety temperature must be set in accordance with EN 61010-2-010 Chapter "Requirements for devices containing or using flammable liquids".
    - The surface temperature of the flammable medium that is exposed to air may not exceed its flash point.  
A danger usually arises if a medium is heated in open vessels.
    - The surface temperature of the heating device may not exceed the value of  $(t - 25) \text{ }^\circ\text{C}$  (= set value of the safety circuit) on the surface of the flammable medium and in contact with air, whereby  $t$  is the fire point of the liquid.  
A danger usually arises if a medium is heated in glass vessels (glass breakage).
- If a setting made by the user (medium temperature or safety temperature) could bring a flammable medium into a state in which the conditions mentioned above could be exceeded, additional measures must be introduced that will protect the user from this danger.

#### **Caution!**

- › Wear your personal protective equipment in accordance with the hazard category of the media to be processed. There may be a risk from:
  - splashing and evaporation of liquids,
  - ejection of parts,
  - release of toxic or combustible gases.
- › Do not touch the temperature sensor while measurements are being taken. This will prevent incorrect results.

### /// Accessories

- › Protect the device and accessories from bumps and impacts.
- › Check the device and accessories for damage before each use. Do not use damaged components.
- › Safe operation is guaranteed only with the use of original IKA accessories.

### /// Power supply / Switching off the device

- › The voltage stated on the type plate must correspond to the power voltage.
- › Do not remove the device battery.
- › For transport purposes, the device must be switched off completely by pressing and holding the touch button for about 10 seconds.

### /// Maintenance

- › The device must only be opened by trained specialists, even during repair.

### /// Disposal instructions

- › The device, accessories and packaging must be disposed of in accordance with local and national regulations.
- ›  Do not throw used battery into your household waste. Dispose of them properly in accordance with statutory regulations.
- End users are obliged by law to return all used disposable and rechargeable batteries. Throwing them into the household waste is prohibited. Disposable / rechargeable batteries containing harmful substances are marked with this symbol to indicate that they may not be disposed of as household waste.



### Intended use

#### /// Use

- › The “PT wireless” device can be used to measure temperature or pH value. To do this, a wireless or USB cable connection to a compatible end device must be established.
- › The built-in battery provides up to 150 hours of operation.

#### /// Area of use

- › Indoor environments similar to that a laboratory of research, teaching, trade or industry area.
- › The safety of the user cannot be guaranteed:
  - if the device is operated with accessories that are not supplied or recommended by the manufacturer,
  - if the device is operated improperly or contrary to the manufacture’s specifications,
  - if the device or the printed circuit board are modified by third parties.

## Unpacking



### /// Unpacking

- › Unpack the device carefully. Any damage should immediately be reported to the carrier (mail, rail or freight forwarding company).

### /// Scope of delivery

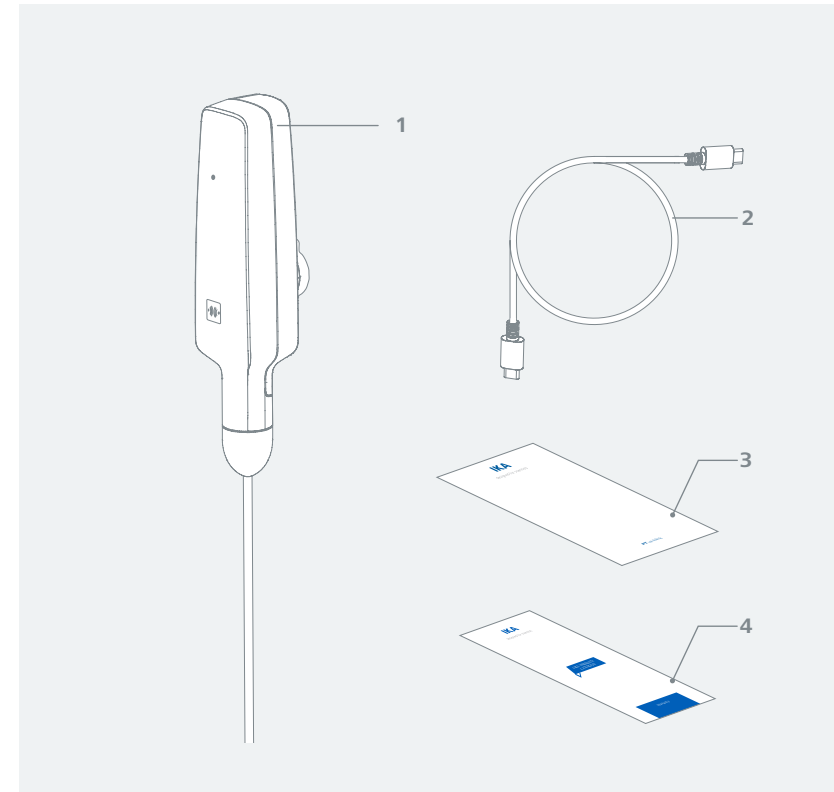

<b>1</b>	PT wireless
<b>2</b>	USB-C to USB-C cable
<b>3</b>	User guide
<b>4</b>	Warranty card

## Operator panel and display

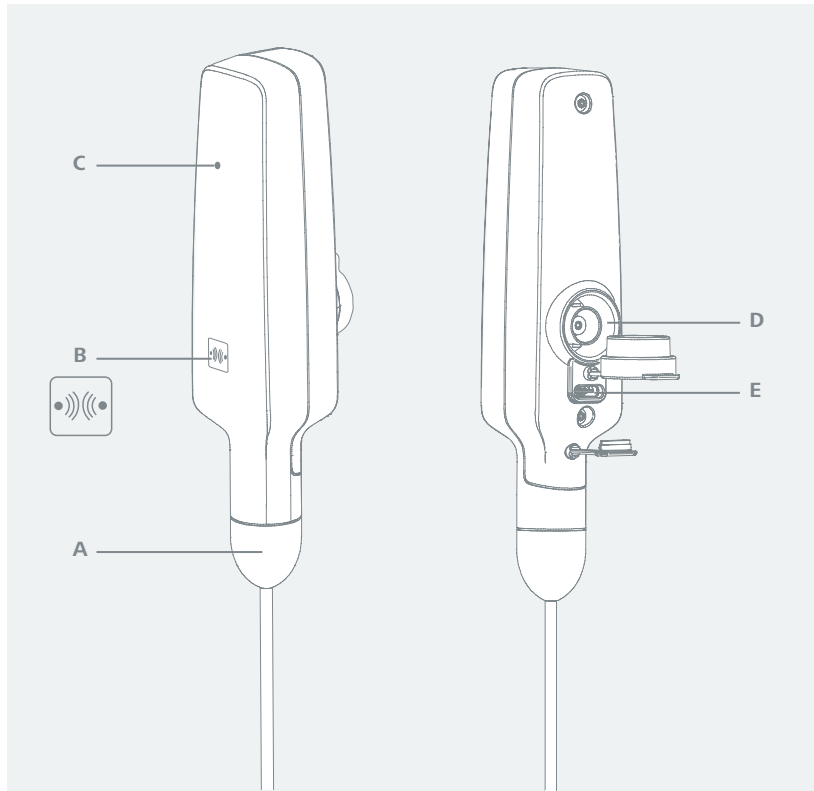

A	Replaceable temperature sensor H 62.51
B	Touch button
C	Status LED
D	BNC port (pH)
E	USB-C port

## Installation



### /// Power on and secure

- › The device must be charged before it is used for the first time. To do this, connect the device to a computer or a suitable power supply (5 V) via the USB-C port. The status LED blinks green during charging. Once charging is complete, the USB-C cable can be disconnected from the device.

**Note:** If the connection between the temperature sensor and the device is faulty, the status LED will light up red continuously and an acoustic signal will be heard. You can stop the acoustic signal by pressing the touch button.

- › Securely attach the device to a stand (e.g., using the H 38 holding rod). Ensure that the temperature sensor is immersed at least 20 mm deep into the medium.

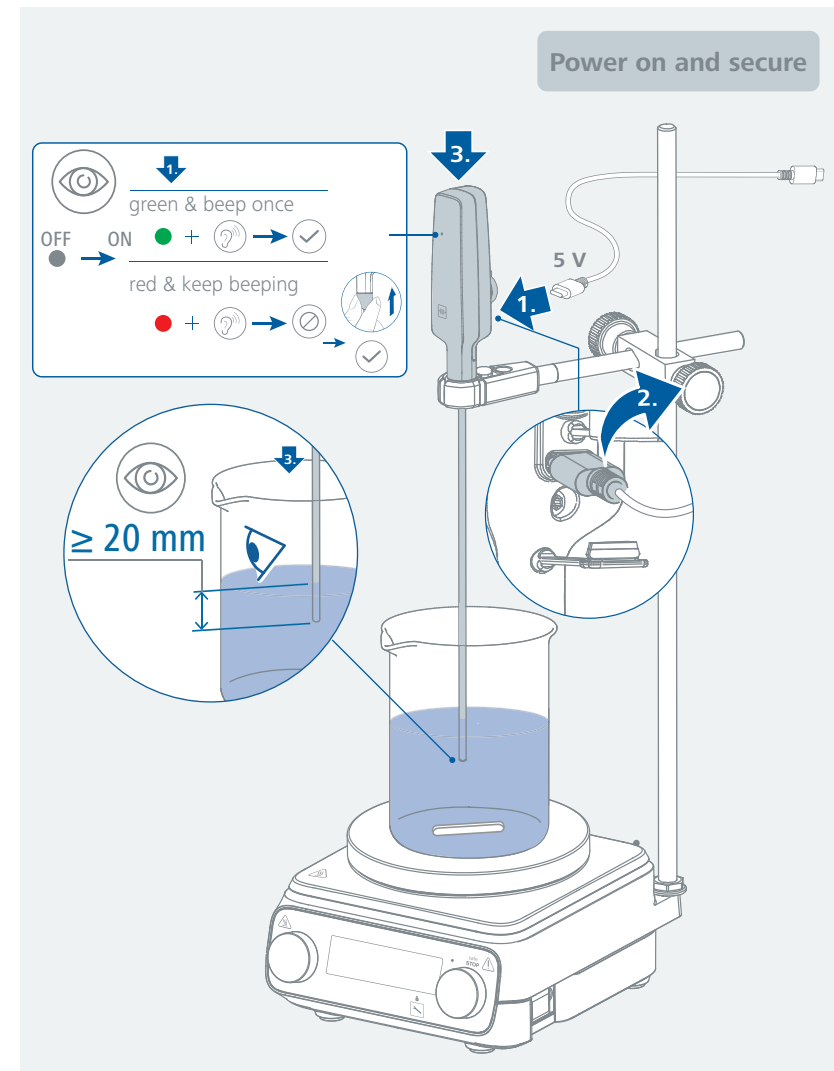



# Operation

## Establishing a wireless connection (Pair)

Press and hold the touch button for 3 seconds to start the connection process. The status LED blinks blue slowly during the search process (30 seconds) and lights up blue continuously when pairing is successful.

## Identify

Briefly press the touch button to identify the terminal connected to the device. The terminal emits an acoustic signal and the display (status LED) blinks. When the device (PT wireless) is identified via the connected terminal device, it emits an acoustic signal and the status LED blinks.

## Disconnect wireless connection (Unpair)

Press and hold the touch button for 3 seconds. The connection will be disconnected and the Status LED color will change from blue to green.

**Warning:** Do not disconnect during an active heating process!

## Standby mode

The device switches to standby mode after 5 minutes of inactivity. The status LED goes out.

**Note:** Standby mode is only activated if there is no connection to a terminal device.

To exit standby mode, briefly press the touch button.

## Switching off / on

To switch off the device completely, press and hold the touch button for about 10 seconds. To switch the device back on, briefly connect it to a power source via the USB-C port.

## Battery charging

The status LED will blink yellow slowly when the battery working time is below 20 hours. Charge the battery via the USB-C port in good time.

During charging, the status LED blinks green slowly and will become green continuously when fully charged.

## pH connection

A pH sensor can be connected via the BNC port on the rear of the device. The measured pH values are shown on the display of the connected terminal device.

## Device error

The status LED lights up red continuously and an acoustic signal is heard when:

- the device itself is damaged,
- the replaceable temperature sensor (H 62.51) has not been assembled in position or connected correctly,
- the measuring range of the device has been exceeded.

Operation

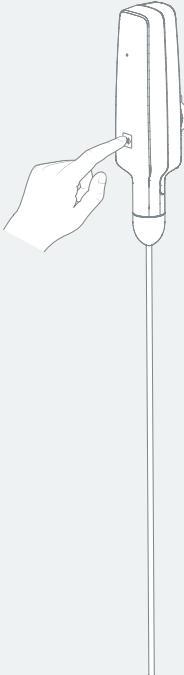

### Pair

Green → 3 sec → Blue: slow blinking → 30 sec → Blue → ✓

### Identify

1 sec → Blue: fast blinking & beeping → ✓

### Unpair

Blue → 3 sec → Green → ✓



### Standby mode

Green → Inactivity No connection 5 min → OFF → 1 sec → Green

### Switching off / on

Green / Blue → 10 sec → OFF → 1 sec → Green

### Battery charging

Yellow: slow blinking (Battery < 20 hours) → Green: slow blinking (50% at 60 minutes, 75% at 90 minutes) → Green

### pH connection

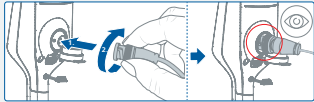

### Device error

Steady red & beep → Replace sensor, Assemble or connect sensor correctly, Switch off sensor

### Behavior of the status LED when the battery working time is below 70 hours (designed for over-weekend application)

#### No wireless connection:

The status LED will blink green for 3 seconds and then yellow for 1 second, in an infinite loop.

#### Wirelessly connected but without heating process:

The status LED will blink blue for 3 seconds and then yellow for 1 second, in an infinite loop.

#### Wirelessly connected with heating process:

The status LED will pulse blue once and then yellow once, in an infinite loop.

### Behavior of the status LED during the heating process (wireless connection)

The status LED blinks blue during the heating process.

The status LED blinks blue rapidly and an acoustic signal sounds when the set temperature is changed on the terminal device.

The status LED blinks yellow slowly when the battery working time is below 20 hours.

The status LED lights up red continuously and an acoustic signal is heard when the device is damaged.

### Behavior of the status LED during the heating process (USB-C to USB-C connection)

The status LED blinks green during the heating process.

The status LED lights up red continuously and an acoustic signal is heard when the device is damaged.

**Note:** When the device is connected to the terminal via the USB-C cable, any existing wireless connection will be disconnected.

## Interfaces and outputs

The device software can be updated with a PC via the USB port.

#### **Notice!**

Please comply with the system requirements together with the operating instructions and help section included with the software.

### /// USB interface

The Universal Serial Bus (USB) is a serial bus for connecting the device to the PC. Equipped with USB devices can be connected to a PC during operation (hot plugging). Connected devices and their properties are automatically recognized.

### /// USB device drivers

Connect the IKA device through the USB data cable to the PC. The data communication is via a virtual COM port.

From Windows 10 and onwards the standard Windows USB driver is automatically loaded and a COM port number is assigned (find details in Windows Device Manager: "USB Serial Port

(COMxx)"). If you have problems with USB communication, first ask your IT system administrator whether access to the USB interface is restricted for data security reasons.

### /// Command syntax and format

The following applies to the command set:

- > Commands are generally sent from the computer (Leader) to the device (Follower).
- > The device sends only at the computer's request. Even fault indications cannot be sent spontaneously from the device to the computer (automation system).
- > Commands are transmitted in capital letters.
- > Commands and parameters including successive parameters are separated by at least one space (Code: hex 0x20).
- > Each individual command (incl. parameters and data) and each response are terminated with Blank CR LF (Code: hex 0x20 hex 0x0d hex 0x20 hex 0x0A) and have a maximum length of 80 characters.
- > The decimal separator in a number is a dot (Code: hex 0x2E).

The above details correspond as far as possible to the recommendations of the NAMUR working party (NAMUR recommendations for the design of electrical plug connections for analogue and digital signal transmission on individual items of laboratory control equipment, rev. 1.1).

The NAMUR commands and the additional specific IKA commands commissioning serve only as low level commands for communication between the device and the PC. With a suitable terminal or communications program these commands can be transmitted directly to the device. The IKA software package, *labworldsoft®*, provides a convenient tool for controlling device and collecting data under MS Windows, and includes graphical entry features.

NAMUR Commands	Function
IN_NAME	Read the device name
IN_PV_1	Read medium actual temperature
IN_PV_80	Read pH value

### /// Connections between device and external devices

#### USB-A to USB-C cable:

This cable is required to connect the USB port to a PC or terminal device.

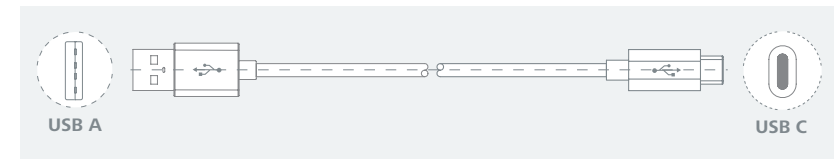

#### USB-C to USB-C cable:

This cable is required to connect the USB port to a PC or terminal device.

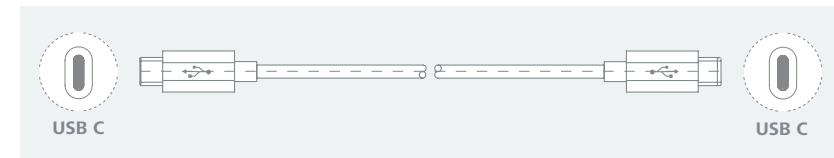

## Maintenance and cleaning

- › The device is maintenance-free. It is only subject to the natural wear and tear of components and their statistical failure rate.

### /// Cleaning

- › For cleaning disconnect the device from the power supply.
- › Use only cleaning agents which have been approved by IKA to clean the devices:  
Water containing surfactant / isopropyl alcohol.
- › Wear protective gloves during cleaning the devices.
- › Electrical devices may not be placed in the cleansing agent for the purpose of cleaning.
- › Do not allow moisture to get into the device when cleaning.
- › Before using another than the recommended method for cleaning or decontamination, the user must ascertain with IKA that this method does not destroy the device.

### /// Replacing extension cable / sensor

- › Pull the temperature sensor downwards with the cover cap until the plastic snap connection has been released.
- › Slide the temperature sensor or extension cable back over the attachment on the device with the cover cap. Ensure that the new accessory is correctly installed and connected.

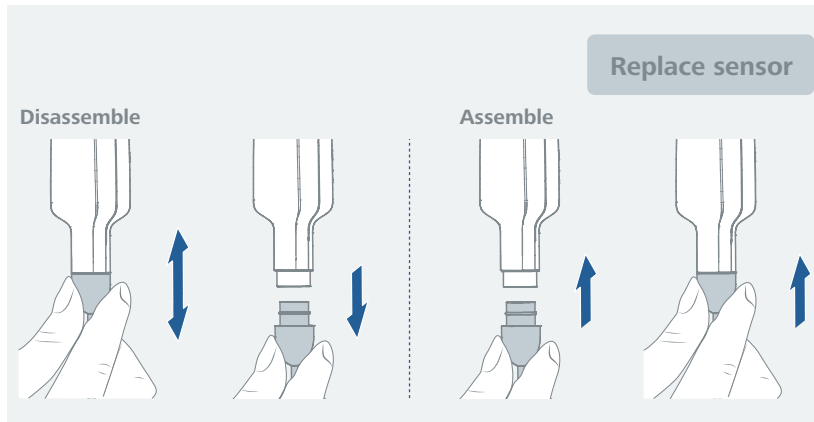

### /// Calibration

- › Temperature calibration can be performed via the connected terminal device (RCT basic / RET basic). It is also possible to perform temperature calibration using the IKA Lab Assistant app.
- › pH calibration can be performed using the IKA Lab Assistant app.

### /// Ordering spare parts

- › When ordering spare parts, please give:
  - device type.
  - serial number, see type plate.
  - position number and description of spare part, see [www.ika.com](http://www.ika.com).
  - software version.

### /// Repairs

- › Please only send in devices for repair that have been cleaned and are free of materials which might present health hazards.
- › For repair, please request the "**Safety Declaration (Decontamination Certificate)**" from IKA or use the downloaded printout of it from IKA website at [www.ika.com](http://www.ika.com).
- › If your appliance requires repair, return it in its original packaging. Storage packaging is not sufficient when sending the device - also use appropriate transport packaging.

## Accessories

- › For accessories see [www.ika.com](http://www.ika.com).



## Technical data

General data	
DC Voltage	5 V
Replaceable temperature sensor	H 62.51
Capacitive touch button	yes
Acoustic warning	yes
Status LED	yes
Permissible ambient temperature	+5 ... +40 °C
Permissible relative humidity	80 %
Protection class according to DIN EN 60529	IP 54
Dimensions (W x D x H)	30 x 380 x 38 mm
Weight	90 g
Operation at a terrestrial altitude	max. 2000 m
Battery	
Rechargeable battery	yes
Battery type	Lithium-ion RCR123A 16340
Battery voltage	3.7 V
Battery capacity	700 mAh
Permissible duration of operation (battery)	max. 150 hours
Battery charging time	50% at 60 minutes 75% at 90 minutes
Battery charging current max.	500 mA
Interface	
USB-C	yes
pH connection (BNC)	yes
WPAN (Wireless Personal Area Network)	yes
Max. communication distance (depends on the building)	15 m
Temperature measurement	
Temperature measuring range (with H 62 sensor)	-20 ... 400 °C
Temperature sensor type	PT 1000 DIN IEC 751 Class A
Temperature measurement resolution (with H 62 sensor)	0.1 K
Temperature sensor measuring accuracy	±0.2 K + Tolerance PT 1000
Immersion depth min.	20 mm
pH measurement	
pH measurement range	0 ... 14
pH measurement accuracy	± 0.1
pH measurement resolution	± 0.01

*Subject to technical changes!*

## Warranty

- › In accordance with IKA Terms and Conditions of Sale, the warranty period is 24 months. For claims under the warranty please contact your local dealer. You may also send the device direct to our factory, enclosing the delivery invoice and giving reasons for the claim. You will be liable for freight costs.
- › The warranty does not cover worn out parts, nor does it apply to faults resulting from improper use, insufficient care or maintenance not carried out in accordance with the instructions in this operating instructions.



designed for scientists

#### **IKA-Werke GmbH & Co. KG**

Janke & Kunkel-Straße 10,  
79219 Staufen, Germany  
Phone: +49 7633 831-0  
eMail: sales@ika.de

#### **USA**

**IKA Works, Inc.**  
Phone: +1 910 452-7059  
eMail: sales@ika.net

#### **KOREA**

**IKA Korea Ltd.**  
Phone: +82 2 2136 6800  
eMail: sales-lab@ika.kr

#### **BRAZIL**

**IKA Brasil**  
Phone: +55 19 3772 9600  
eMail: sales@ika.net.br

#### **MALAYSIA**

**IKA Works (Asia) Sdn Bhd**  
Phone: +60 3 6099-5666  
eMail: sales.lab@ika.my

#### **CHINA**

**IKA Works Guangzhou**  
Phone: +86 20 8222 6771  
eMail: info@ika.cn

#### **POLAND**

**IKA Poland Sp. z o.o.**  
Phone: +48 22 201 99 79  
eMail: sales.poland@ika.com

#### **JAPAN**

**IKA Japan K.K.**  
Phone: +81 6 6730 6781  
eMail: info\_japan@ika.ne.jp

#### **INDIA**

**IKA India Private Limited**  
Phone: +91 80 26253 900  
eMail: info@ika.in

#### **UNITED KINGDOM**

**IKA England LTD.**  
Phone: +44 1865 986 162  
eMail: sales.England@ika.com

#### **VIETNAM**

**IKA Vietnam Company Limited**  
Phone: +84 28 38202142  
eMail: sales.lab-vietnam@ika.com

#### **THAILAND**

**IKA Works (Thailand) Co. Ltd.**  
Phone: +66 2059 4693  
eMail: sales-lab.thailand@ika.com

#### **TURKEY**

**IKA Turkey A.Ş.**  
Phone: +90 216 394 43 43  
eMail: sales.turkey@ika.com

#### **KENYA**

**IKA Works Kenya Ltd.**  
Phone: +254 112 323 745  
eMail: sales.kenya@ika.com

#### **UGANDA**

**IKA Works Kampala Limited**  
Phone: +254 112 323 745  
eMail: sales.uganda@ika.com

#### **SPAIN**

**IKA Works Spain, S. L.**  
**Barcelona**  
eMail: sales.spain@ika.com

Register now: [www.ika.com/register](http://www.ika.com/register)



[www.ika.com](http://www.ika.com)



IKAworlwide // #lookattheblue

Technical specifications may be changed without prior notice.