

IKA

designed for scientists

EUROSTAR 60 control
EUROSTAR 100 control
EUROSTAR 20 high speed control

ENGLISH

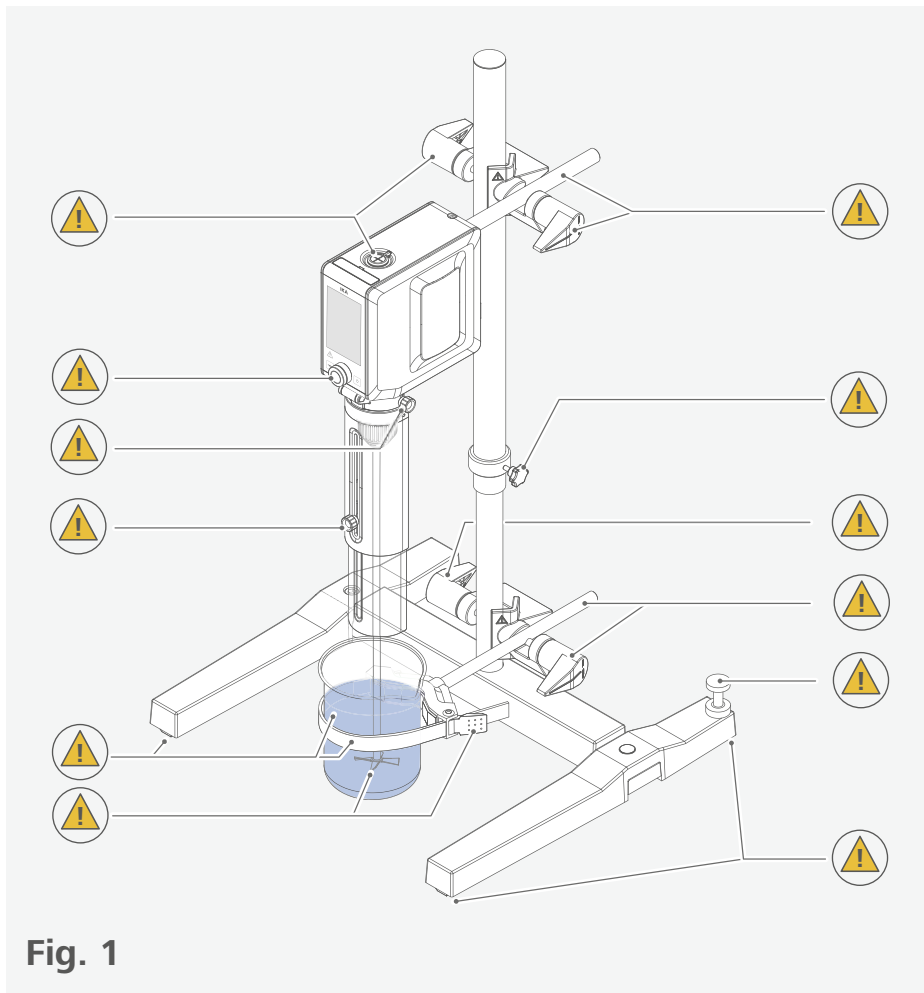











Fig. 1

	EU Declaration of conformity	6
	Note for USA (FCC)	6
	Note for Canada (IC)	6
	Explication of warning symbols	7
	Safety instructions.....	8
	Intended use.....	11
	Useful information	11
	Speed	12
	Output shaft	13
	Unpacking	14
	Installation	16
	Operator panel and display	22
	Operation	24
	Menu navigation and structure	36
	Interfaces and outputs	50
	Maintenance and cleaning	54
	Troubleshooting (EUROSTAR 60/100 control)	55
	Error codes	58
	Accessories	61
	Permitted IKA stirrer tools	61
	Technical data.....	62
	Warranty	64
	Torque graph	64



EU Declaration of conformity

We declare under our sole responsibility that this product corresponds to the directives 2014/35/EU and 2006/42/EC, 2014/30/EU and 2011/65/EU and conforms with the following standards or normative documents: EN 61010-1, EN 61010-2-051, EN 61326-1, EN 60529 and EN ISO 12100.

Wireless module:

Directive: 2014/53/EU Standards: EN 60950-1, EN 300328, EN 301489-1, EN 301489-17

A copy of the complete declaration of conformity or further declarations of conformity can be requested at sales@ika.com.



Note for USA (FCC)

This device complies with Part 15 of the FCC rules. Any changes or modifications not expressly approved by the Manufacturer could void the user's authority to operate the equipment.

This device complies with Part 15 of the FCC rules subject to the following two conditions:

- (1) This device may not cause harmful interference, and
- (2) This device must accept all interference received, including interference that may cause undesired operation.

NOTE:

This equipment has been tested and found to comply with the limits for a Class B digital device, pursuant to part 15 of the FCC Rules.

These limits are designed to provide reasonable protection against harmful interference when the equipment is operated in a commercial environment.

This equipment generates, uses, and can radiate radio frequency energy and, if not installed and used in accordance with the instruction manual, may cause harmful interference to radio communications. Operation of this equipment in a residential area is likely to cause harmful interference in which case the user will be required to correct the interference at his own expense.



Note for Canada (IC)

This device complies with Industry Canada license-exempt RSS standard(s). Operation is subject to the following two conditions:

- (1) This device may not cause interference
- (2) This device must accept any interference, including interference that may cause undesired operation of the device.

This device complies with Health Canada's Safety Code 6 / IC RSS-210. The installer of this device should ensure that RF radiation is not emitted in excess of the Health Canada's requirement.

Explication of warning symbols



/// Warning symbols



Danger!

Indicates an (extremely) hazardous situation, which, if not avoided, will result in death, serious injury.



Warning!

Indicates a hazardous situation, which, if not avoided, can result in death, serious injury.



Caution!

Indicates a potentially hazardous situation, which, if not avoided, can result in injury.



Notice!

Indicates practices which, if not avoided, can result in equipment damage.

/// General Symbols

A — Position number



Correct/Result

Shows the correct execution or the result of an action step.



Wrong

Shows the incorrect execution of an action step.



Note

Displays action steps that require particular attention to detail.



Beep

Shows action steps where audible beeps can be heard.



Closed lock!

Indicates the status of "locked".



Open lock!

Indicates the status of "Unlocked".



Safety instructions

/// General information

- › **Read the operating instructions completely before starting up and follow the safety instructions.**
- › Keep the operating instructions in a place where it can be accessed by everyone.
- › Ensure that only trained staff work with the device.
- › Follow the safety instructions, guidelines, occupational health and safety and accident prevention regulations.
- ›

Danger!

- › Pay attention to the marked sites in Fig. 1.
Beware of the risk of:
 - flammable materials
 - glass breakage as a result of mechanical stirring power

Caution!

- › Wear your personal protective equipment in accordance with the hazard category of the medium to be processed, there is a risk of:
 - splashing of liquids
 - projectile parts
 - body parts, hair, clothing and jewellery getting caught.
- › Safe operation is only guaranteed with the accessories described in the "Accessories" section. Refer to the operating instructions for the accessories.
- ›
- › The device must only be used in a technically perfect condition.

/// Device setup

Danger!

- › The power switch of the IKA device must be accessed immediately, directly and without risk at any time. If installation or positioning cannot ensure this access at all times, an additional EMERGENCY STOP switch that can be easily accessed must be installed in the work area.

Warning!

- › Ensure stable assembly. The vessel used for stirring must be secured.
- › Use stirring shaft protective equipment!

Notice!

- › Set up the stand in a spacious area on an even, stable, clean, non-slip, dry and fireproof surface.
- › Avoid knocking and impacting on the lower end of the shaft and the chuck. Even minor, invisible damage can lead to imbalance and uneven shaft action.
- › You must ensure that the stirring element is securely clamped in the chuck!
- › All screw connections must be properly tightened.
- › The high torque developed by the device requires particular care in the choice of stand, cross sleeve and anti-rotation element for the agitating vessel.

/// Viscosity (Only for EUROSTAR 60/100 control)

Notice!

- › To ensure a reliable and accurate viscosity measurement, the following preparations for commissioning must be observed:
 - Set up the device on a firm, level surface that is free from vibrations or movement.
 - Position the device vertically downwards.
 - Follow the assembly instructions / setup instructions for the respective mixing tools exactly.
- › Follow the measurement steps exactly as described in the "Viscosity" section.
- › For optimal results, we recommend using the IKA stirring tool as well as following the measurement conditions for viscosity defined by IKA.
- › If you use other stirring tools, calibrate them carefully and simulate the viscosity measurement as described in the "Viscosity" section. Define the correct setup conditions for your stirring tools. If you have any questions, please contact IKA application support.

/// Working with the device

Danger!

- › Do not use the device in explosive atmospheres, it is not EX-protected.
- › With substances capable of forming an explosive mixture, appropriate safety measures must be applied, e.g. working under a fume hood.
- › To avoid body injury and property damage, observe the relevant safety and accident prevention measures when processing hazardous materials.
- › The device is not suitable for hand-held operation.
- › Do not touch rotating parts during operation!

Warning!

- › Pathogenic materials must only be processed in closed vessels under a suitable fume hood. If you have any questions, please contact IKA application support.
- › The operation of a free rotating shaft end is prohibited. Therefore, for safety reason, only insert through the stirring tool over the upper edge of housing at standstill.

Caution!

- › Make certain that the device is set at the lowest speed before commissioning; otherwise, the device may begin running at the speed set in last operation. Gradually increase the speed. Please observe the max. permitted speed for the stirring element. Never set higher speed.

Notice!

- › Covers or parts that can be removed from the device without tools must later be refitted to ensure safe operation. This will prevent the infiltration of foreign objects, liquids and other contaminants.
- › Imbalance of the output shaft, the chuck and in particular the stirring tools can lead to uncontrolled resonant vibrational behavior of the device and the whole assembly. Glass apparatus and stirrer containers can be damaged or shattered by this. It can cause injury to the operator, also can damage the rotating stirring tool. In this case exchange the stirring tool for one without imbalance or remedy the cause of the imbalance. If there is still imbalance, return it to the dealer or the manufacturer along with a description of the fault.
- › There may be electrostatic activity between the medium and the output shaft which could cause a direct danger.

- › Never operate the device with the stirrer tools rotating freely. Ensure that parts of the body, hair, jewelry or items of clothing cannot be trapped by the rotating parts.
- › Pay attention when setting the speed to any imbalance of the stirrer tools and possible spraying of the medium to be stirred.
- › Ensure that the stand does not start to move.
- › Only process media that will not react dangerously to the extra energy produced through processing. This also applies to any extra energy produced in other ways, e.g. through light irradiation.
- › Reduce the speed if:
 - the medium splashes out of the vessel because the speed is too high,
 - the device is not running smoothly,
 - the device begins to move around because of dynamic forces,
 - an error occurs.

/// Accessories

- › Protect the device and accessories from bumping and impacting.
- › Check the device and accessories beforehand for damage each time when you use them. Do not use damaged components.

/// Power supply / switching off the device

Notice!

- › If the device is operated too long in overload or if the ambient temperature is too high, the device switches off permanently until switch on the device again.
- › The voltage stated on the type plate must correspond to the power voltage.
- › The socket for the power cord must be easily accessible.
- › Socket must be earthed (protective ground contact).
- › After an interruption in the power supply during a stirring process, the device does not restart automatically.
- › Disconnect the power plug before attaching or changing any accessories.
- › Disconnect the power plug before cleaning, maintenance and transportation of the unit.

/// Maintenance

- › The device must only be opened by trained specialists, even during repair. The device must be unplugged from the power supply before opening. Live parts inside the device may still be live for some time after unplugging from the power supply.
- › The lithium coin cell battery (BR 2032) inside the device must be replaced regularly. We recommend replacing it every five years.
- › The lithium coin cell battery in the device can be replaced by IKA service or an IKA authorized service provider.

/// Disposal instructions

- › The device, accessories, packaging and battery must be disposed of in accordance with local and national regulations.
- ›  Do not dispose of used batteries in normal household waste; dispose of them properly in accordance with legal requirements.

Intended use

/// Use

EUROSTAR 60/100 control: For stirring and mixing liquids from low to high viscosity – with different stirring tools and, if required, with adjustable rotation direction reversal.

Note: Reliable and precise measurement of dynamic viscosity is only possible under defined conditions and only with clockwise stirring.

EUROSTAR 20 high speed control: For mixing/stirring liquids from low to medium viscosities with various stirring tools.

Intended use: Stand device (chuck points down)

/// Range of use

Indoor environment similar to that a laboratory for research, teaching, trade or industry.

The safety of the user cannot be guaranteed:

- › if the device is operated with accessories that are not supplied or recommended by the manufacturer.
- › if the device is operated improperly or contrary to the manufacturer's specifications.
- › if the device or the printed circuit boards are modified by third parties.

Useful information

The stirring device is suitable for continuous operation. The motor current is limited electronically. The device has an anti-stall and anti-overload system. If a fault occurs, a safety circuit immediately switches off the motor permanently until switch on the device again. A fault occurs if the safe functioning of the device is not guaranteed.



Speed

/// Speed – normal operation

Speed - regulated (no speed deviation):

The speed is monitored and regulated by processor-controlled. The target speed is constantly compared with the actual rotation speed value of the output shaft and variations corrected. This guarantees a constant speed even if the viscosity of the substance being stirred changes. Fluctuations in mains voltage within the permitted tolerance range have no effect on the quality of regulation and constancy of speed. The speed is set using the front knob or the touch screen. During normal operation the speed value on the display corresponds to the speed of the output shaft in revolutions per minute (rpm).

/// Speed – overload operation

When solid or semi-viscous substances are added, the stirrer can be run for a brief period in overload status. When running in the overload range (for instance if the viscosity has increased at a particular stage of the process) the speed will reduce to a degree sufficient to keep the torque on the stirrer shaft within the rated torque of the device.

Overload status 1:

The machine is already running in the overload range, the target speed does not yet correspond to the actual speed. This condition is maintained as long as neither the motor current nor the temperature exceeds the permitted limit values.

Message on the display: The orange overload symbol () appears.

Overload status 2:

When the device meets a fluctuating load which is over double of the nominal torque, the actual speed of the stirrer shaft will go down quickly to stop.

Message on the display: Error code: 15240702 (see "Error codes" section).

Output shaft

/// EUROSTAR 60/100 control

The clamping chuck and output shaft permit clamping IKA recommended stirrer tools (see section "Permitted IKA Stirrer tools"). The output shaft is designed as a hollow shaft and the opening on the top side of the housing is closed with a plastic cover. When the stirrer cover is opened, it is possible for stirring shaft to be pushed out over the top edge of the housing at standstill, e.g. during changing container. For safety reasons, the stirrer cover must be pushed back into the opening of the housing so that it is properly closed. This is the only way to ensure that working with the unit is safe and that media cannot enter the device.

Notice!

Please see section "Safety instructions"!

/// EUROSTAR 20 high speed control

The output shaft has cone seat specially for precision shaft. Stirring elements can be screw-connected on the precision shaft.

Unpacking

- > Please unpack the device carefully.
- > Any damage should be notified immediately to the shipping agent (post office, railway network or logistics company).



/// EUROSTAR 60/100 control

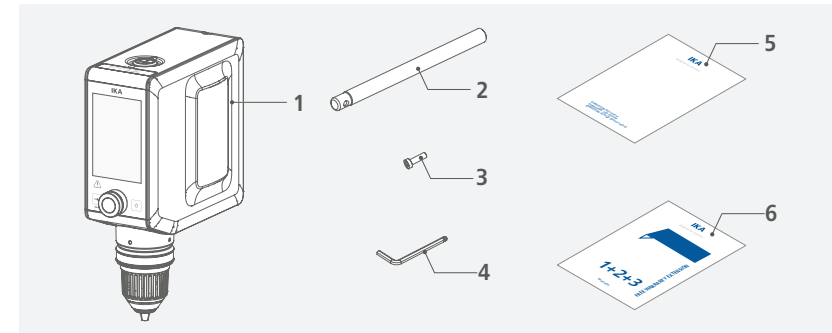

1	EUROSTAR 60/100 control	4	Hexagon socket offset screw key
2	Extension arm	5	User guide
3	Hexagonal socket screw	6	Warranty card

/// EUROSTAR 20 high speed control

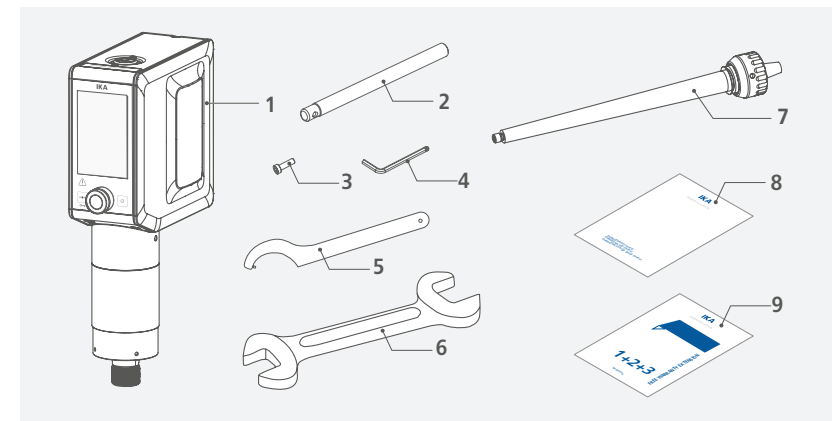

1	EUROSTAR 20 high speed control	6	Open-end wrench
2	Extension arm	7	R 6000 precision shaft
3	Hexagonal socket screw	8	User guide
4	Hexagon socket offset screw key	9	Warranty card
5	Hook spanner		

Device setup

/// EUROSTAR 60/100 control

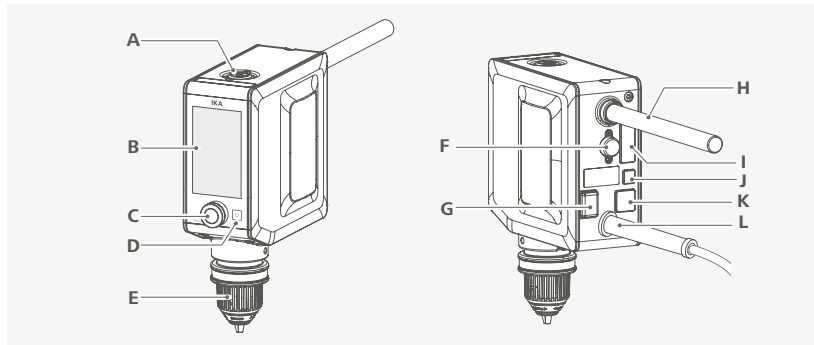

A	Stirring shaft cap	G	Power switch
B	Touch screen	H	Extension arm
C	Control knob	I	RS 232 interface
D	Standby button	J	USB interface
E	Keyless chuck	K	Ethernet interface
F	Temperature sensor interface	L	Power cord

/// EUROSTAR 20 high speed control

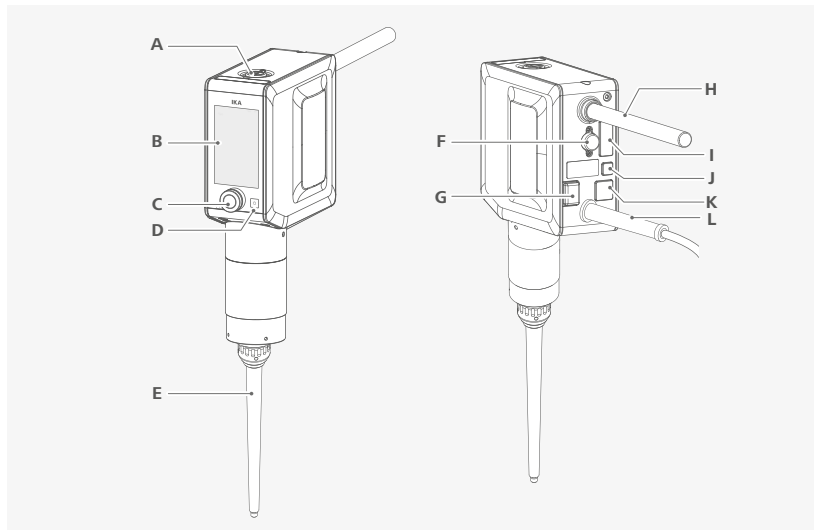

A	Stirring shaft cap	G	Power switch
B	Touch screen	H	Extension arm
C	Control knob	I	RS 232 interface
D	Standby button	J	USB interface
E	R 6000 precision shaft	K	Ethernet interface
F	Temperature sensor interface	L	Power cord

Installation

/// Assembling the extension arm to the overhead stirrer

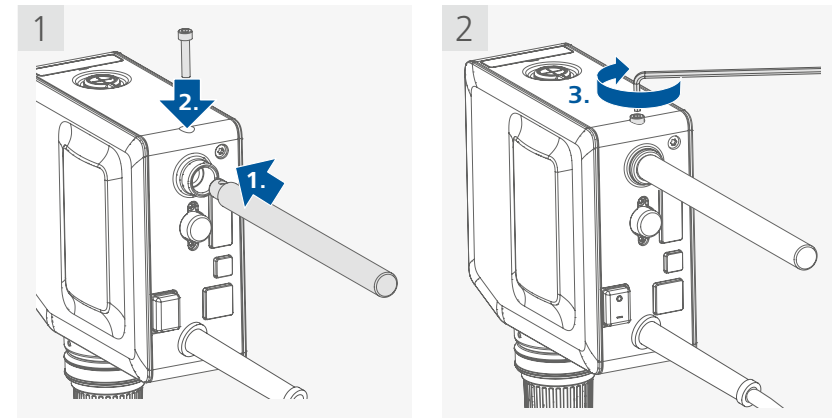

/// Assembling the overhead stirrer to the stand

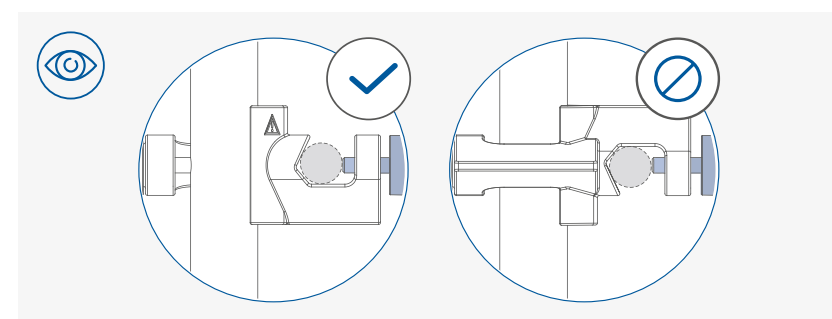
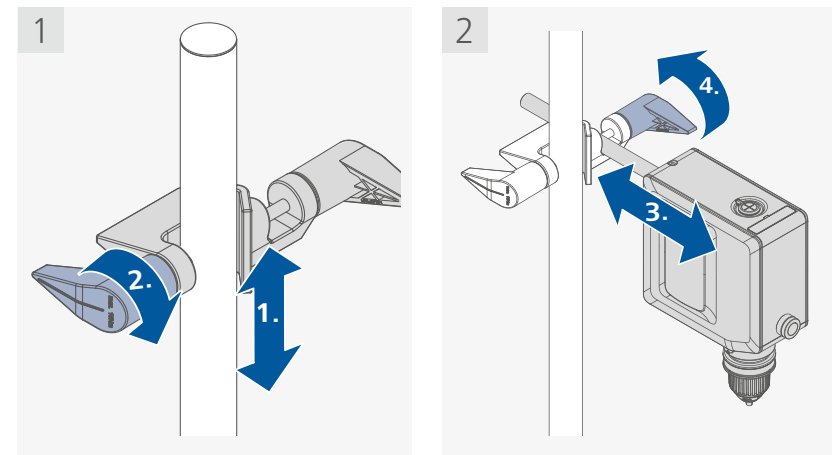

/// Assembling the stirring element using the chuck

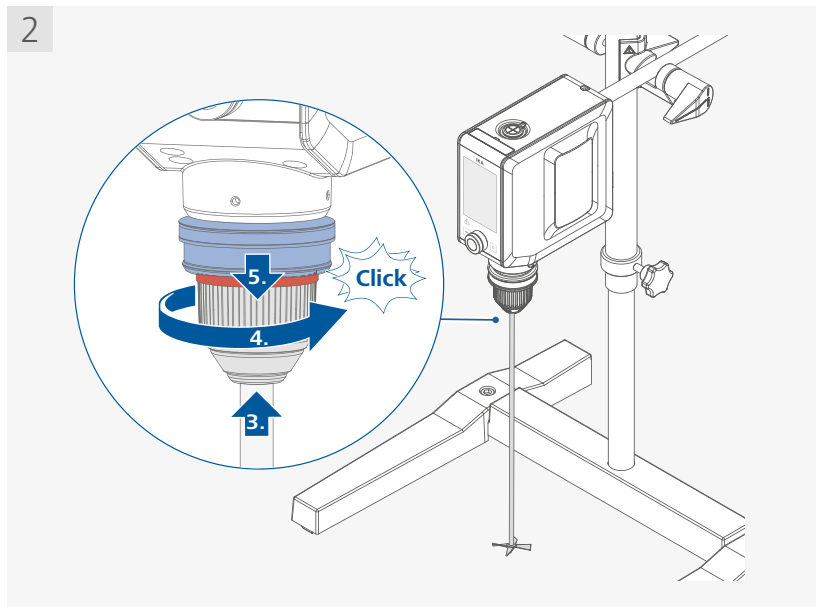
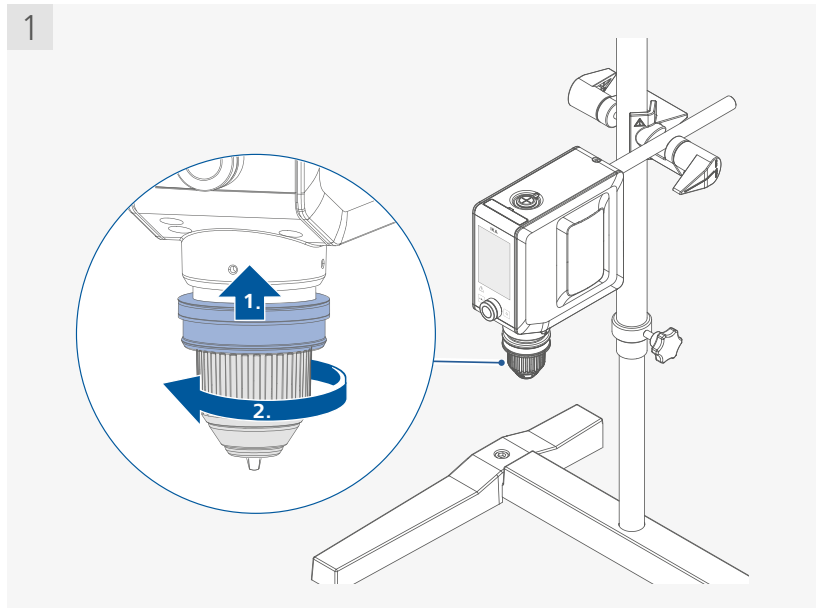

Note: Only for EUROSTAR 60/100 control.

/// Securing the mixing vessel to the stand

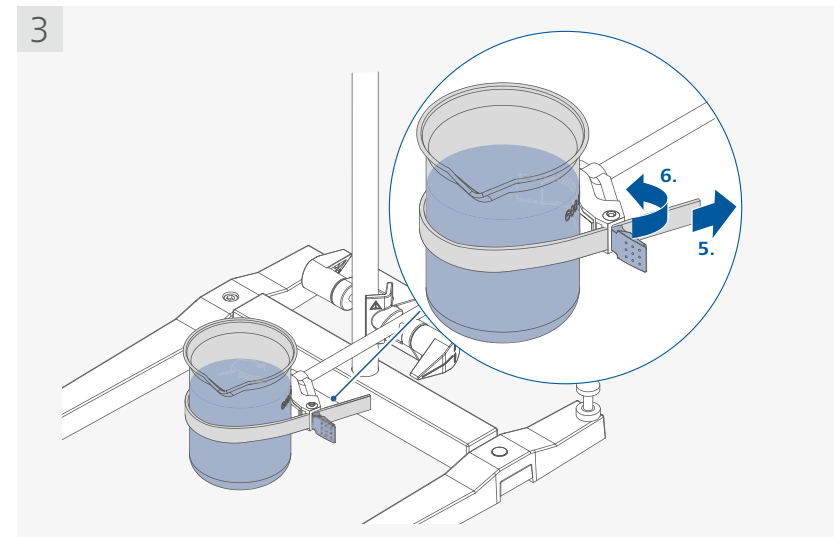
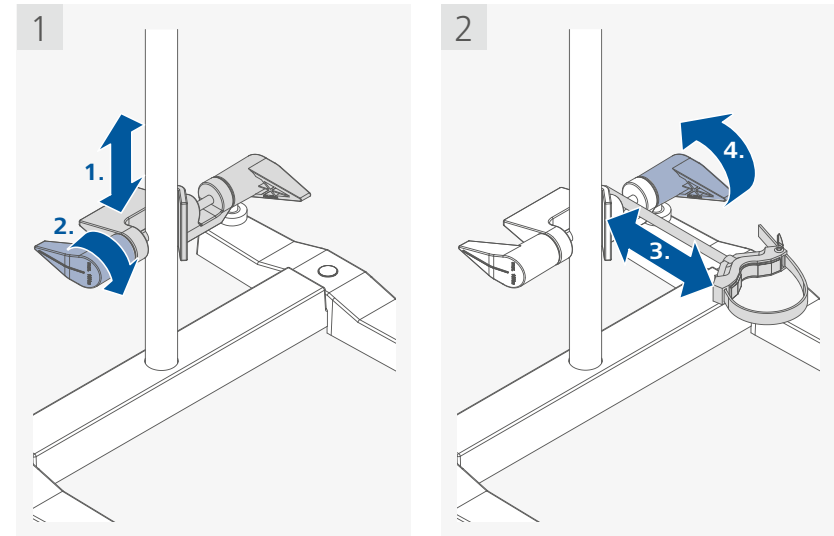

/// Adjust device height on the stand R 2723

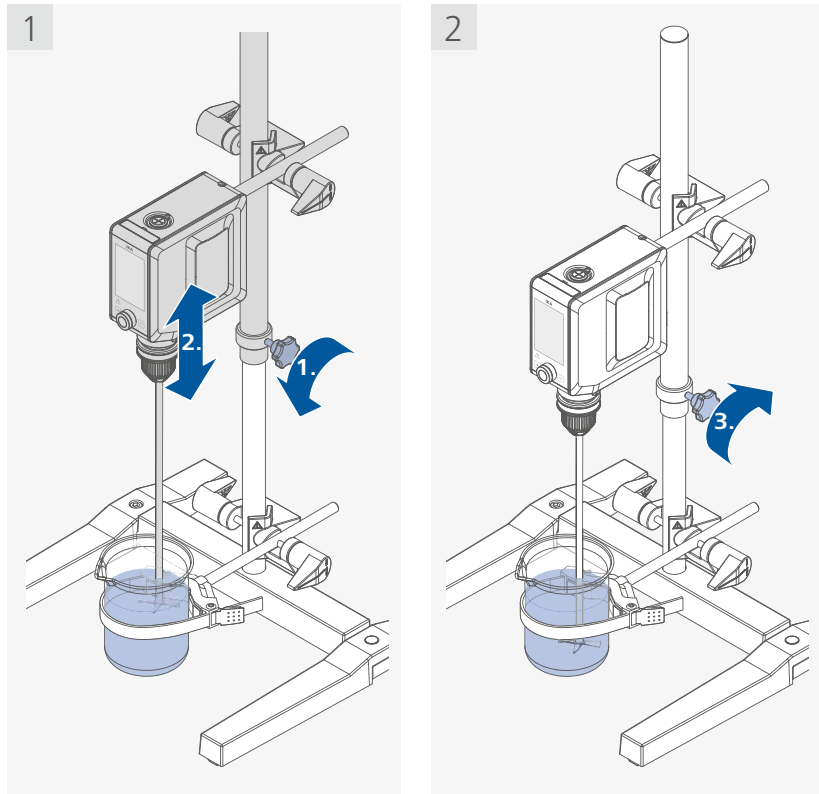

/// Securing and adjusting the stirring shaft protector

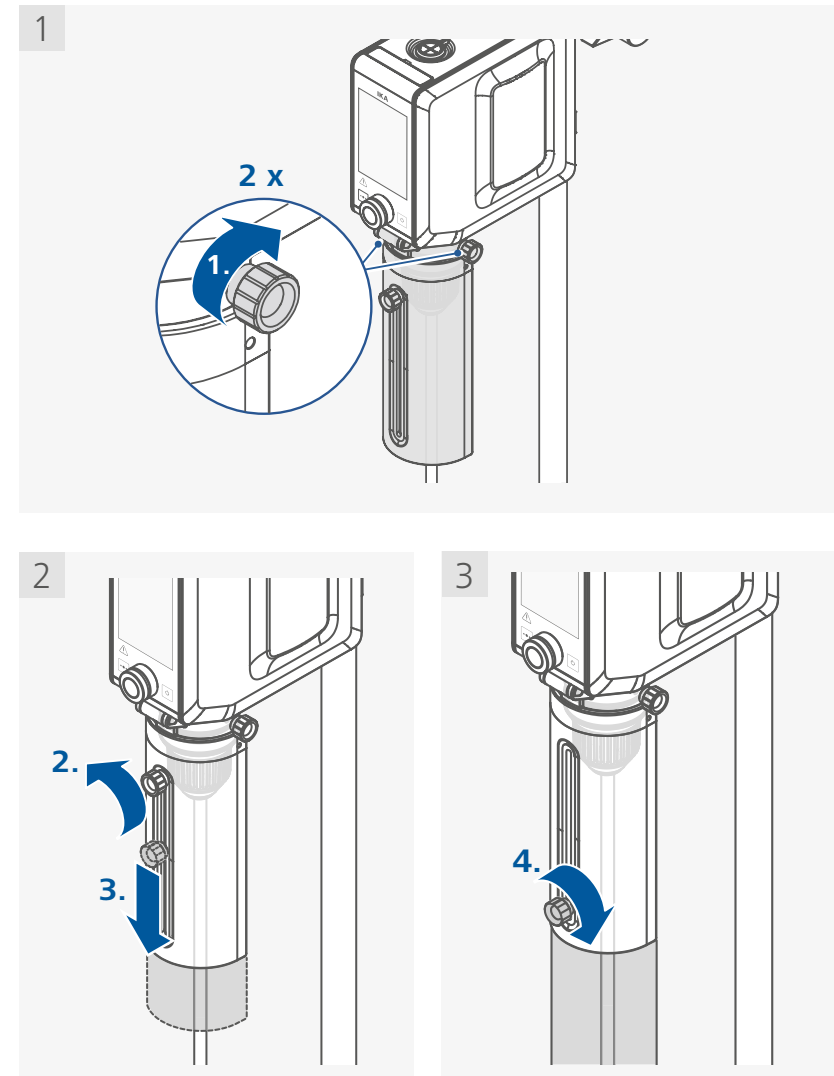

/// Connecting to the power

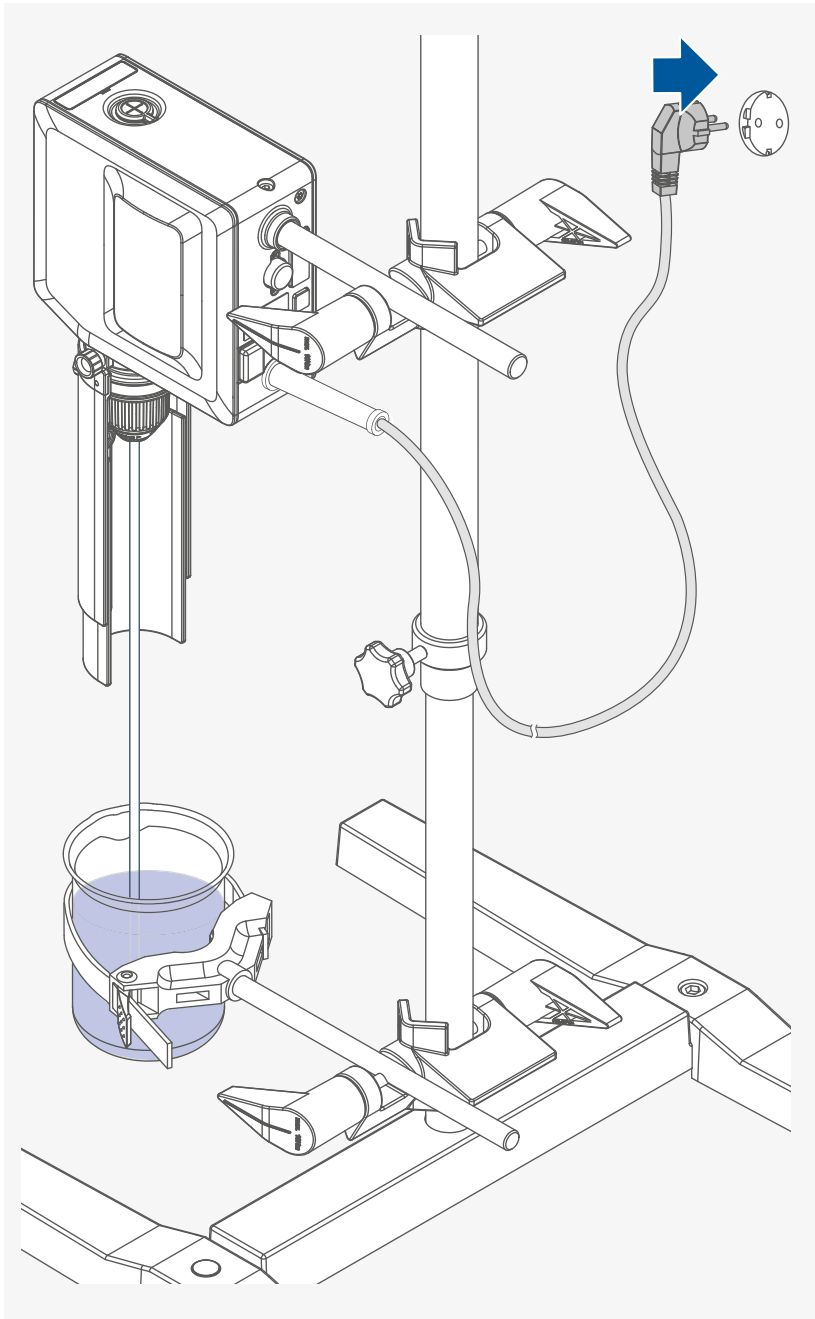

Operator panel and display

/// Explanation of the control elements

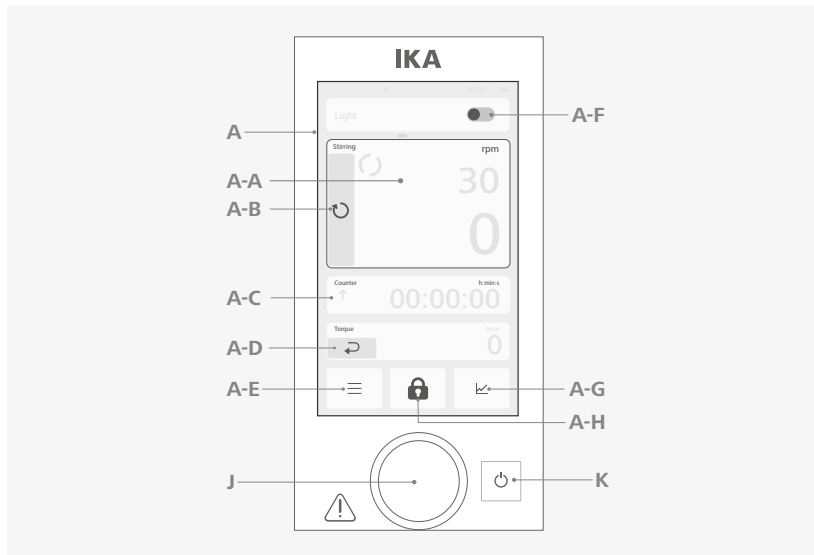

Device control elements / buttons		Function
A	Touch screen	A-A Speed tile: Accesses to stirring settings.
		A-B Changes the stirring direction.
		A-C Timer/counter: Opens the timer and counter settings.
		A-D Reset Torque to Zero.
		A-E Menu: Opens the main menu.
		A-F Switch Light On/Off.
		A-G Open Graph Screen
		A-H Locks/unlocks control elements (press and hold button for 2 seconds).
J	Rotary/push knob	Adjusts speed and timer. Start/stop the device functions.
K	Standby button	Press and hold for 0.5 seconds, no power disconnection.

i The virtual buttons displayed change depending on the settings of the device.

/// Explanation of symbols on the working screen

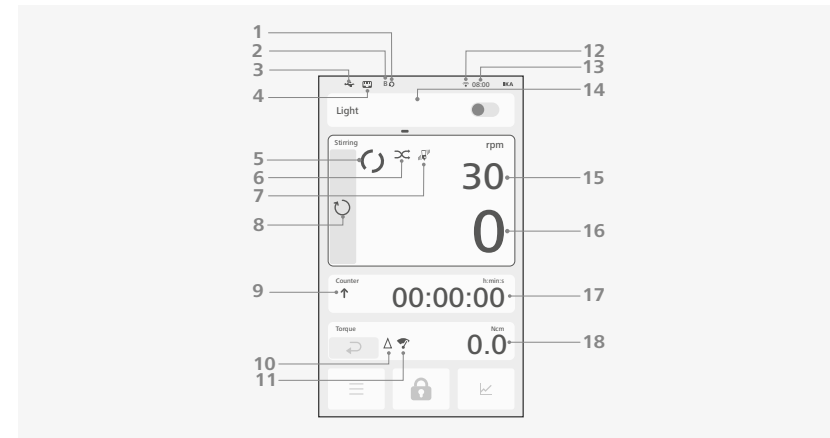

Working screen – symbols and indicators	Meaning
1	Restart Device restarted after power failure.
2	Operating mode (A/B/C) Shows the selected operating mode.
3	USB connection USB cable connected.
4	Ethernet connection Ethernet cable connected.
5	Operation symbol Device function is active.
6	Chaotic mixing Chaotic mixing function enabled.
7	Low sensitivity active.
	Medium sensitivity active.
	High sensitivity active.
8	Rotation direction Indicates the direction of rotation (clockwise or counterclockwise).
9	Timer/Counter Counter active. Timer active.
10	Torque reset Torque value has been reset to zero.
11	Overload The device is overloaded.
12	Device connected to a network.
	No network connection.
13	Current time Shows the current time.
14	Functions bar Shows the configured functions.
15	Setpoint for actual speed Target value for actual speed.
16	Actual speed Actual speed value.
17	Timer/Counter value Shows timer/counter value.
18	Torque value Shows current torque value.

i The symbols displayed change depending on the status and settings of the device.

Note: Only for EUROSTAR 60/100 control.



Operation

⚠ Notice!

Check whether the voltage given on the type plate corresponds to the available mains voltage. The socket used must be earthed (fitted with earth contact).

If these conditions have been met, the machine is ready for operation when the mains plug is plugged in.

If these conditions are not met, safe operation is not guaranteed and the machine could be damaged.

Observe the ambient conditions (temperature, humidity, etc.) listed under "Technical Data".

/// Switching on

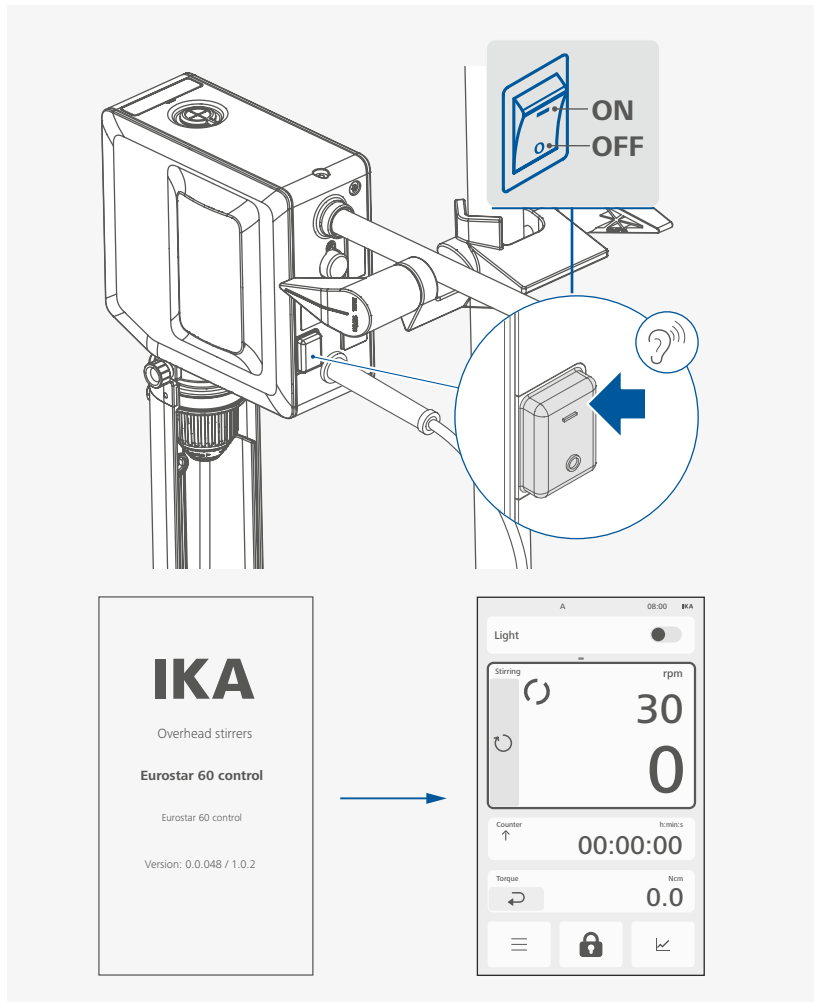

/// Setting the speed

> Set the speed with the control knob

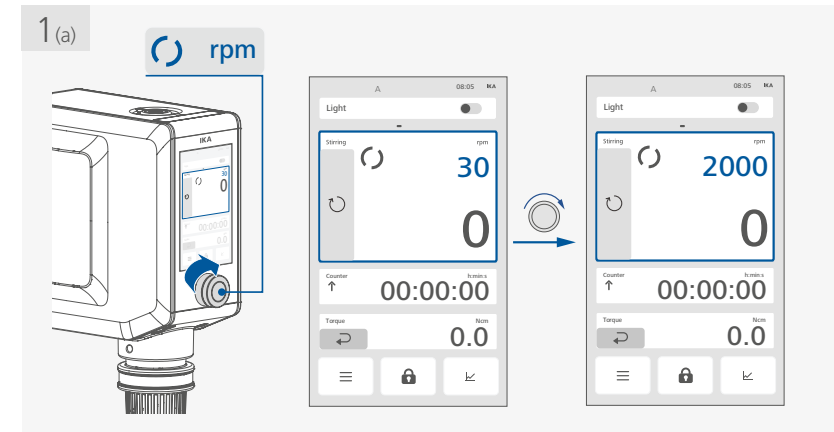

> Set the speed with touch screen

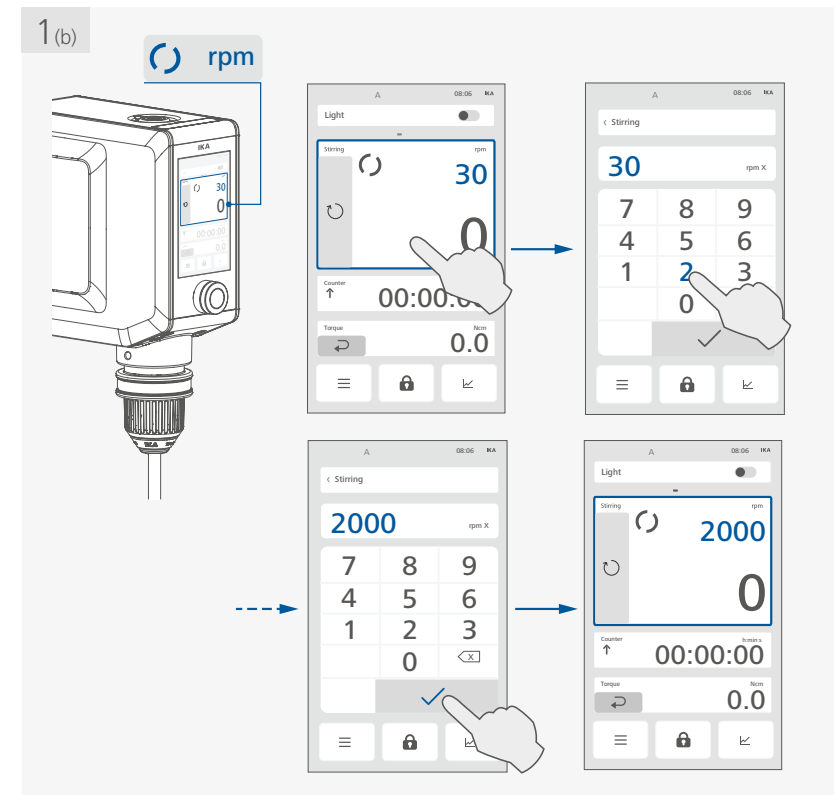

/// Setting the rotation direction (Only for **EUROSTAR 60/100 control**)

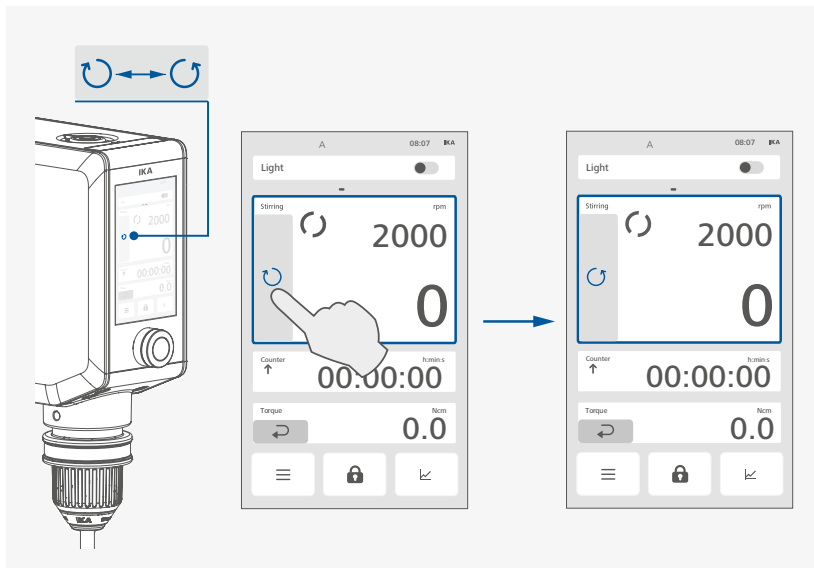

> Set the counter/timer with control knob

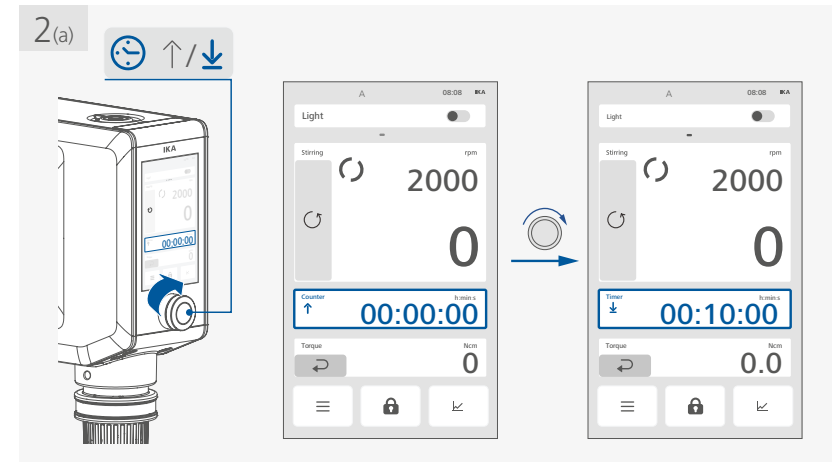

/// Setting the timer/counter

> Activate the timer/counter setting

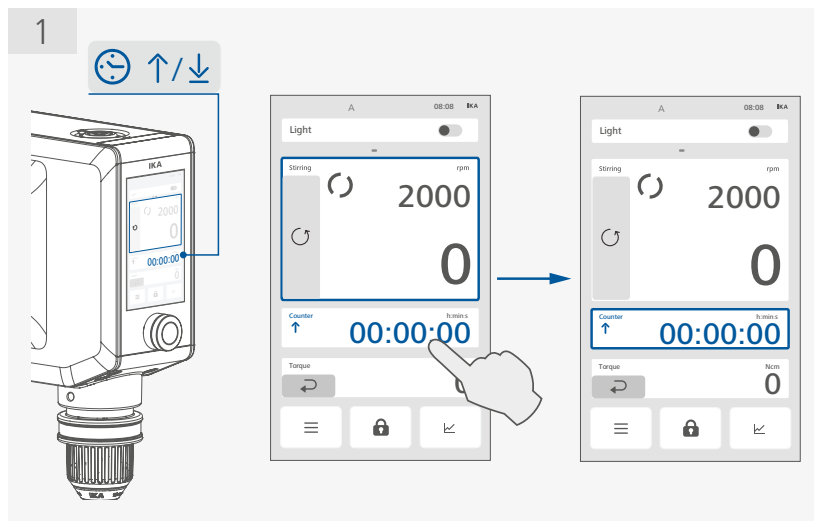

> Set the counter/timer with touch screen

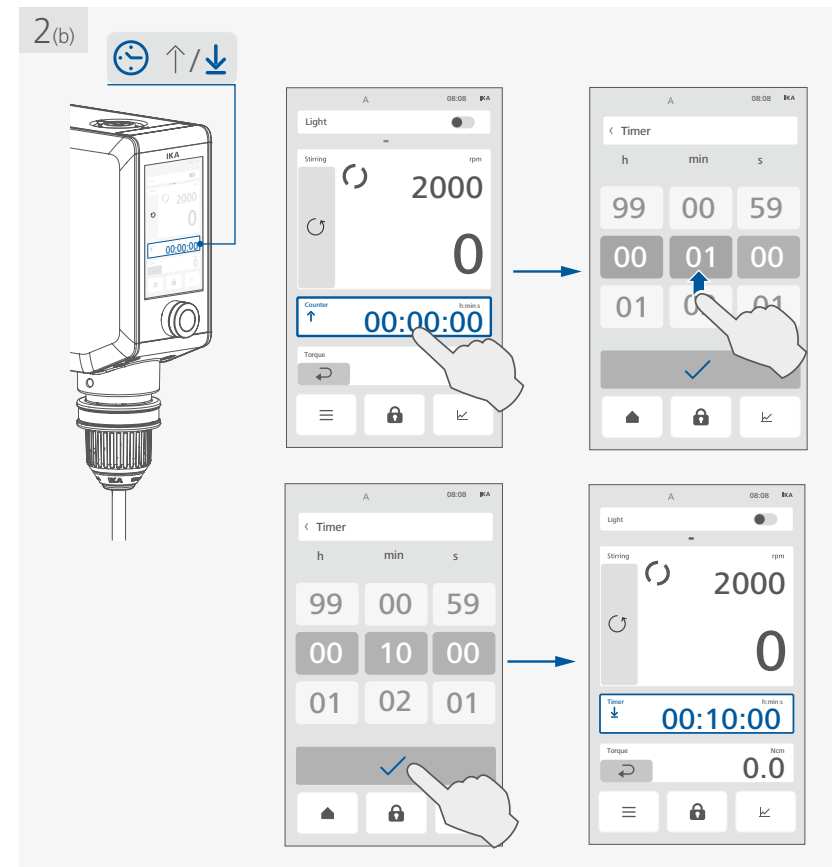

- If the value of the timer/counter setting is set to 00:00:00 [h:min:s], the counter function is activated and the corresponding symbol (↑) appears. When the device function is started, this value automatically starts to run from 00:00:00 [h:min:s] to maximum value 99:59:59 [h:min:s]. After reaching the maximum value, the device keeps running.
- If the value of the timer/counter is set to a value more than 00:00:00 [h:min:s], the timer function is activated and the corresponding symbol (↓) appears. Once the set timer value has elapsed, the device function stops automatically and the last set timer value is displayed. The maximum timer value is 99:59:59 [h:min:s].
- When the device function is activated, the timer setting can be checked by touching the counter/timer tile and reset if necessary.
- The device function can be stopped by pressing the control button (C). This stops the timer and resets it to the last set value.

/// Starting the device function

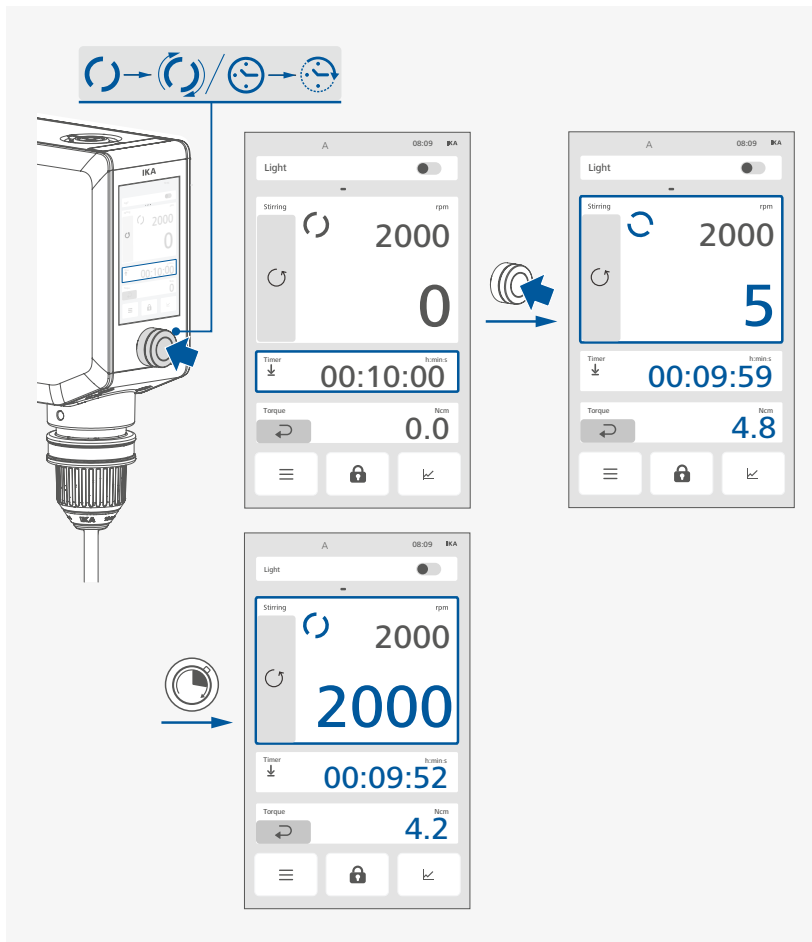

/// Resetting the torque

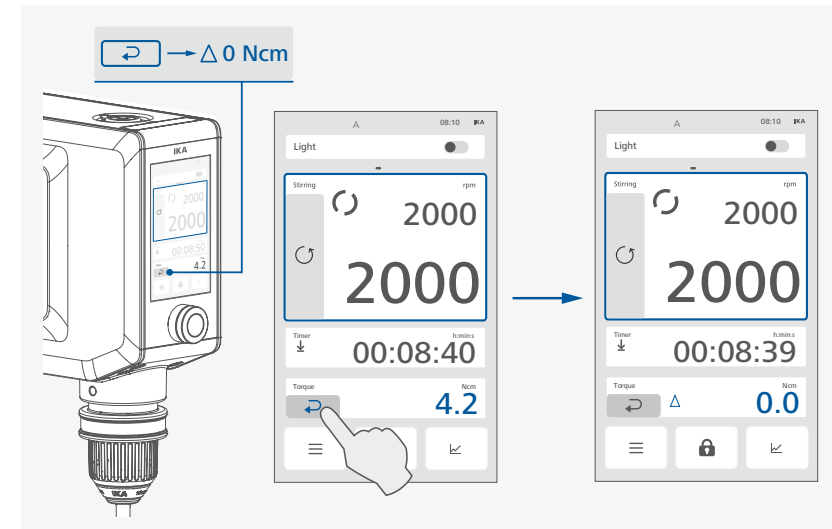

- By resetting the torque, the torque value can be reset to 0 Ncm and the Δ symbol appears before the torque value.

/// Locking/unlocking the settings

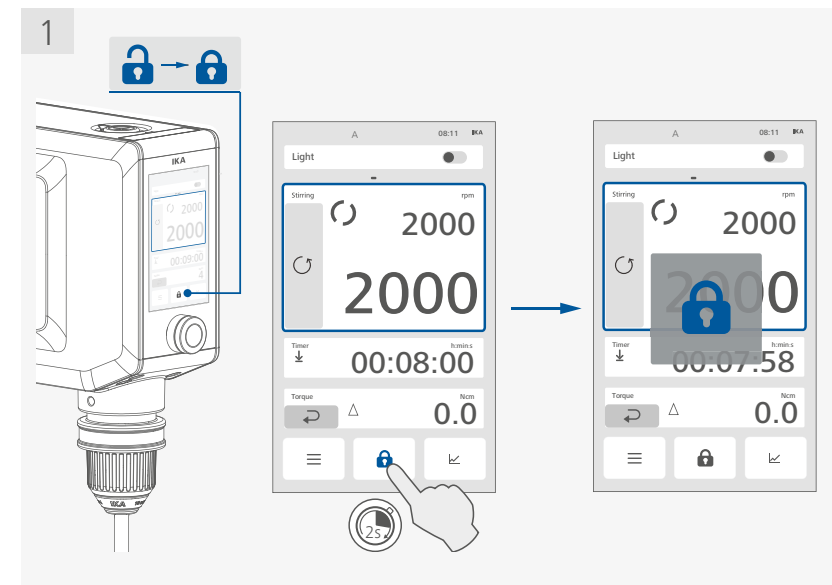

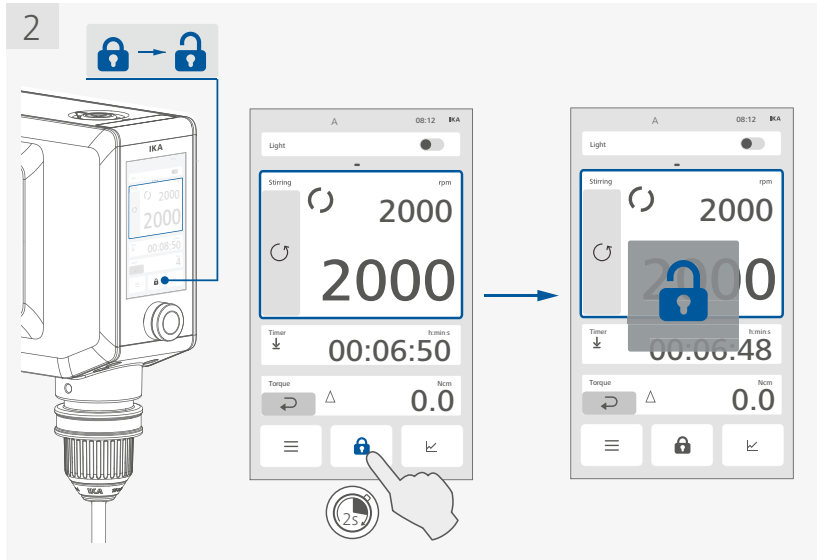

- i**
- › Keep touching lock button about 2 seconds, the device settings will be locked and the lock symbol (🔒) will appear on the screen.
 - › When the settings are locked, the lock symbol (🔒) appears when you touch any button or press/turn the control knob.
 - › Keep touching lock button about 2 seconds again, the device settings are unlocked and unlock symbol (🔓) appears on the screen.
 - › **Note:** During running, you can stop the device by pressing the control knob twice. The lock function will be deactivated.

/// Stopping the device function

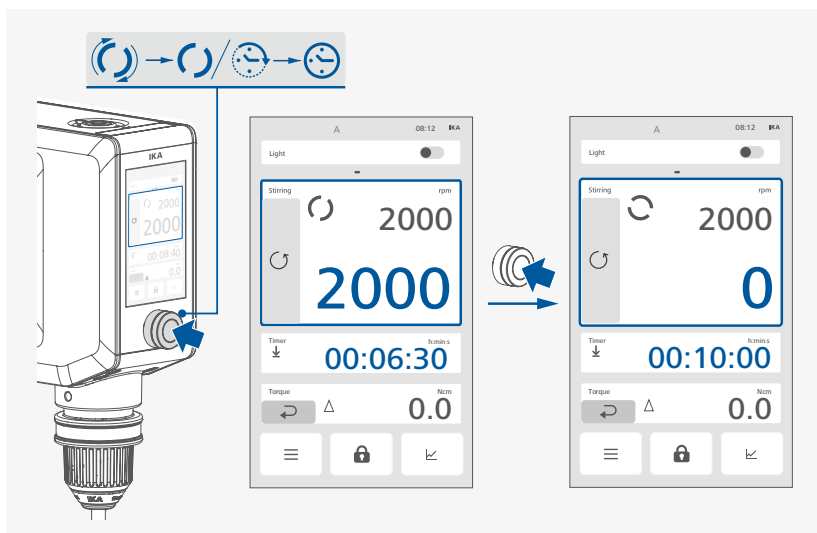

/// General setting of the screen

- › Scroll left and right screens in the function bar

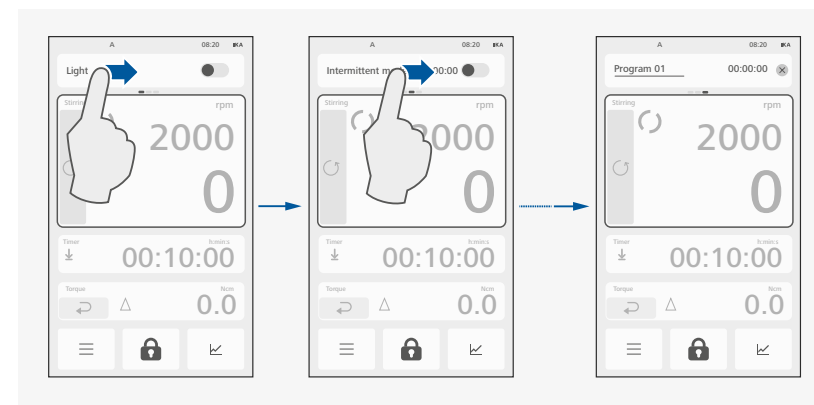

- i**
- You can switch between the display of "Light" and "Intermittent mode" or "Program" by sliding the function bar.
- Note:** You can only switch between the displays when the "Intermittent mode" or "Program" is activated.

- › Scroll up and down screens

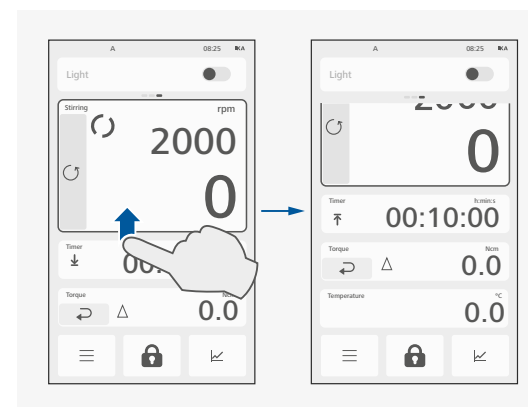

- i**
- Slide the value tiles up/down with your finger, the value tiles can be scrolled and displayed on the screen.
- Note:** You can only scroll up and down the screen if the screen does not fully display the all the set parameters.

› Speed screen layout editing shortcuts

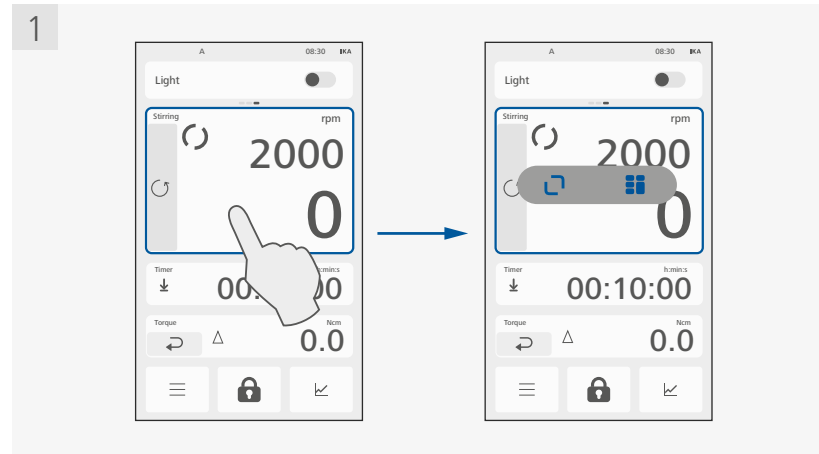

i Keep touching speed value tile, screen layout editing icons appear on the screen.

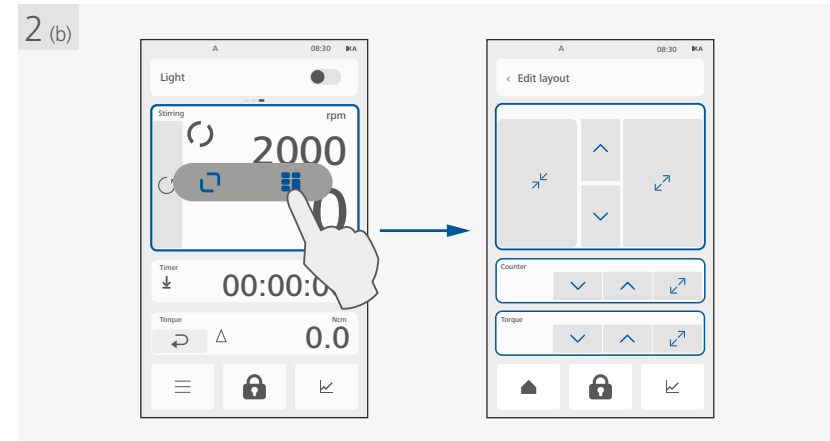

i - Touch the layout icon (■), the screen displays the all value tiles.
 - Touch icon (↖) or (↘) to adjust the size of the selected value tile.
 - Touch icon (^) or (v) to adjust the position of the selected value tile.

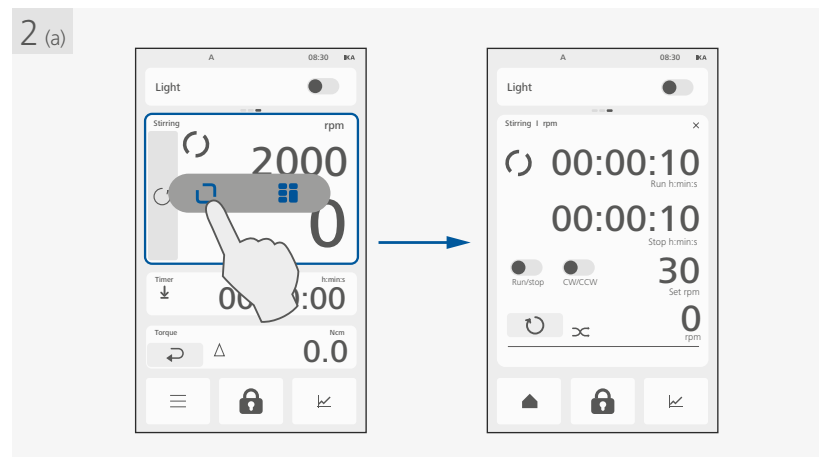

i - Touch the single value screen icon (◻), the screen only displays the selected value tile.
 - Adjust detailed settings for every function:

✕	Switches off the single value screen / return to main screen.
●	Switches on/off the intermittent function.
● CW/CCW	Switches on/off CW (clockwise) / CCW (Counterclockwise).
↻	Changes the rotation directions.
∞	Indicates the chaotic mixing function is activated.

Note: Only for EUROSTAR 60/100 control.

› Timer/counter screen layout editing shortcuts

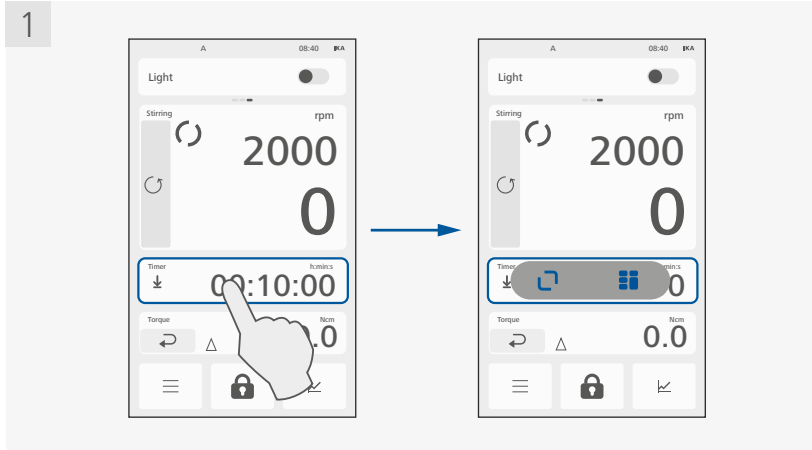

i Keep touching timer/counter value tile, screen layout editing icons appear on the screen.

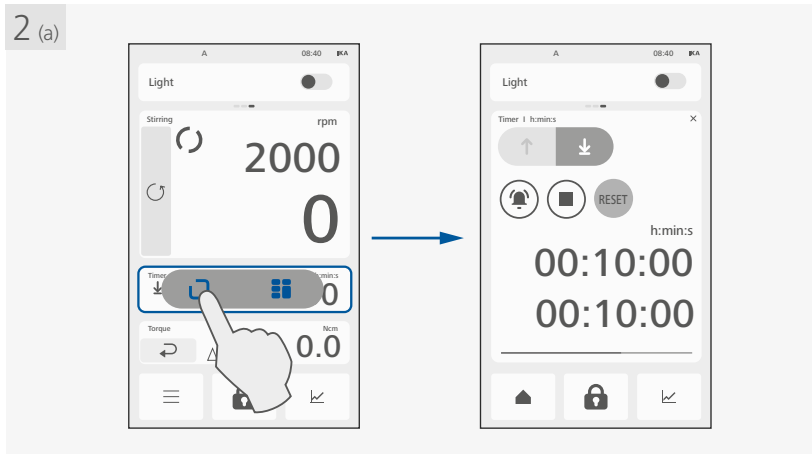

i - Touch the single value screen icon (□), the screen only displays the selected value tile.
 - Adjust detailed settings for every function:

✕	Switch off the single value screen / return to main screen.
↑	Highlight this button to activate the counter function.
↓	Highlight this button to activate the timer function.
🔔	Highlight this button to activate the beep alter when the timer elapses.
🛑	Highlight this button to stop the running of the device when the timer elapse.
🔄	Press this button to reset the actual counter/timer value.

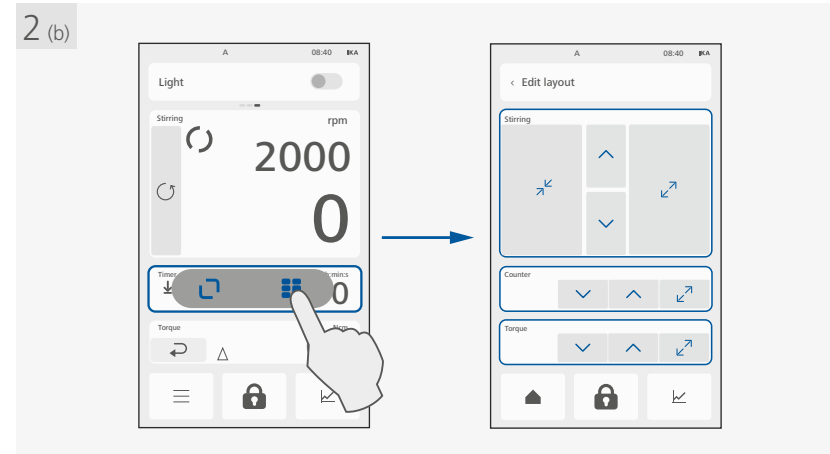

i - Touch the multi-value screen icon (☰), the screen displays the all value tiles.
 - Touch icon (↔) or (↷) to adjust the size of the selected value tile.
 - Touch icon (^) or (v) to adjust the position of the selected value tile.

/// Activate standby mode

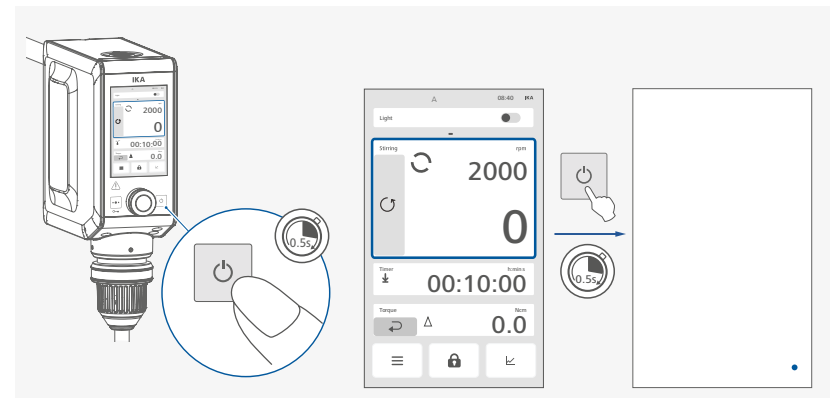

i An LCD dot in the bottom right-hand corner indicates the standby status.



Menu navigation and structure

/// Menu navigation

- > Enter the menu: Touch the menu button (☰).
- > Edit the menu options:
 - Touch and select/confirm the menu options.
 - Activate or deactivate the sub-menu options. The icon (⬤) indicates the deactivated menu options. The icon (◐) indicates the activated menu options.
 - Select the menu options by touching icon (○).
 - The icon (●) indicates the selected menu options.
 - Edit the value with the keyboard or dial.
 - Confirm the settings by touching button (✓).
 - Perform the selected menu options by touching button (OK).
 - Cancel to perform the selected menu options by touching button (Cancel).
- > Navigate one step back: Touch back button (<).
- > Leave menu / return to main screen: Touch home button (🏠).

/// Menu structure

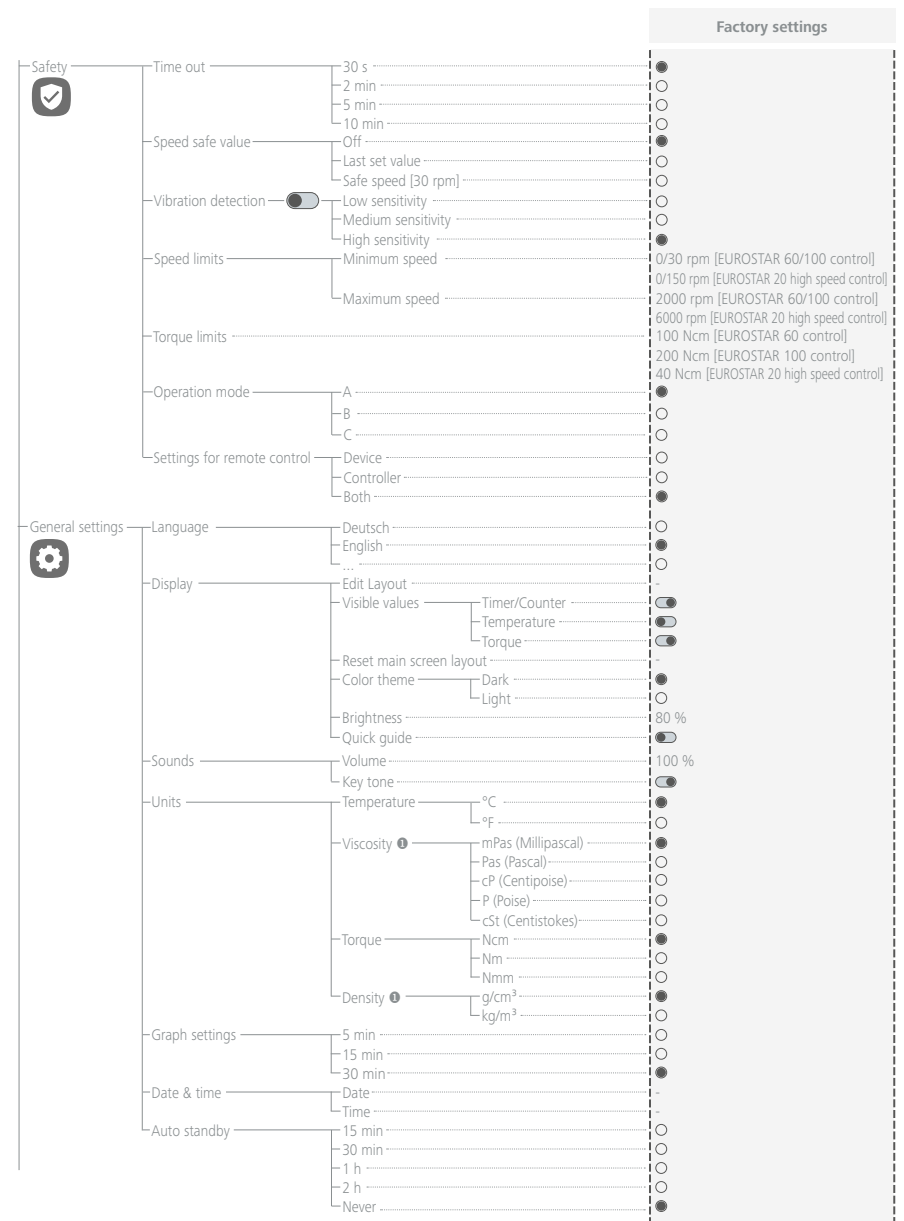
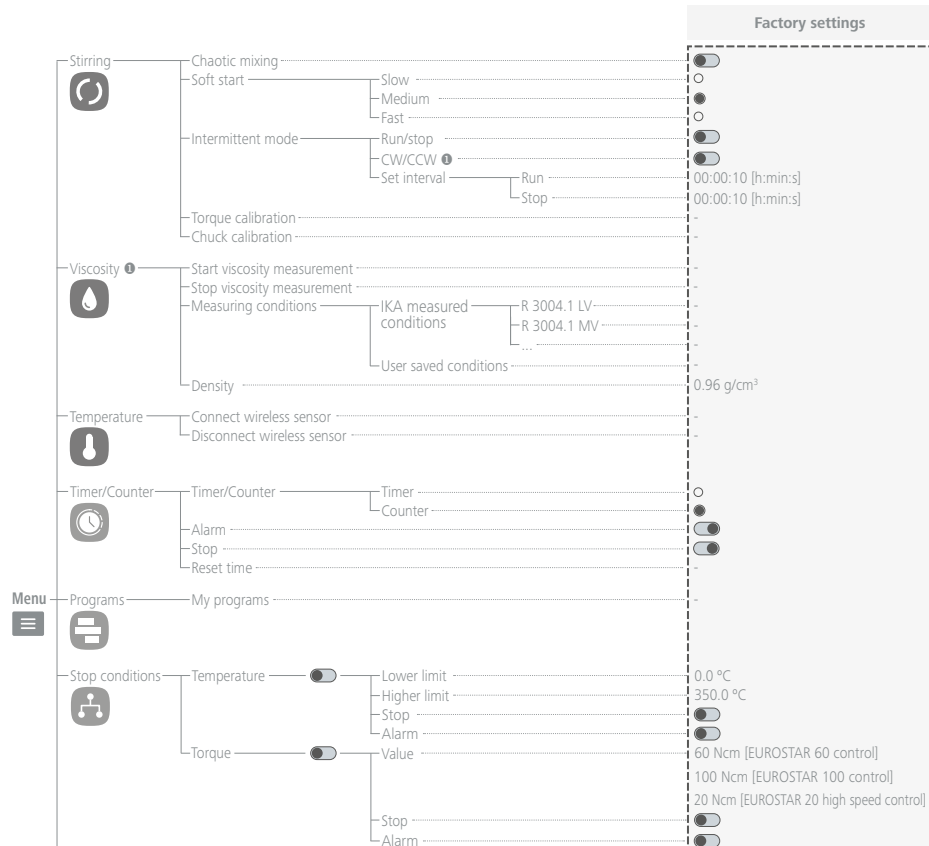

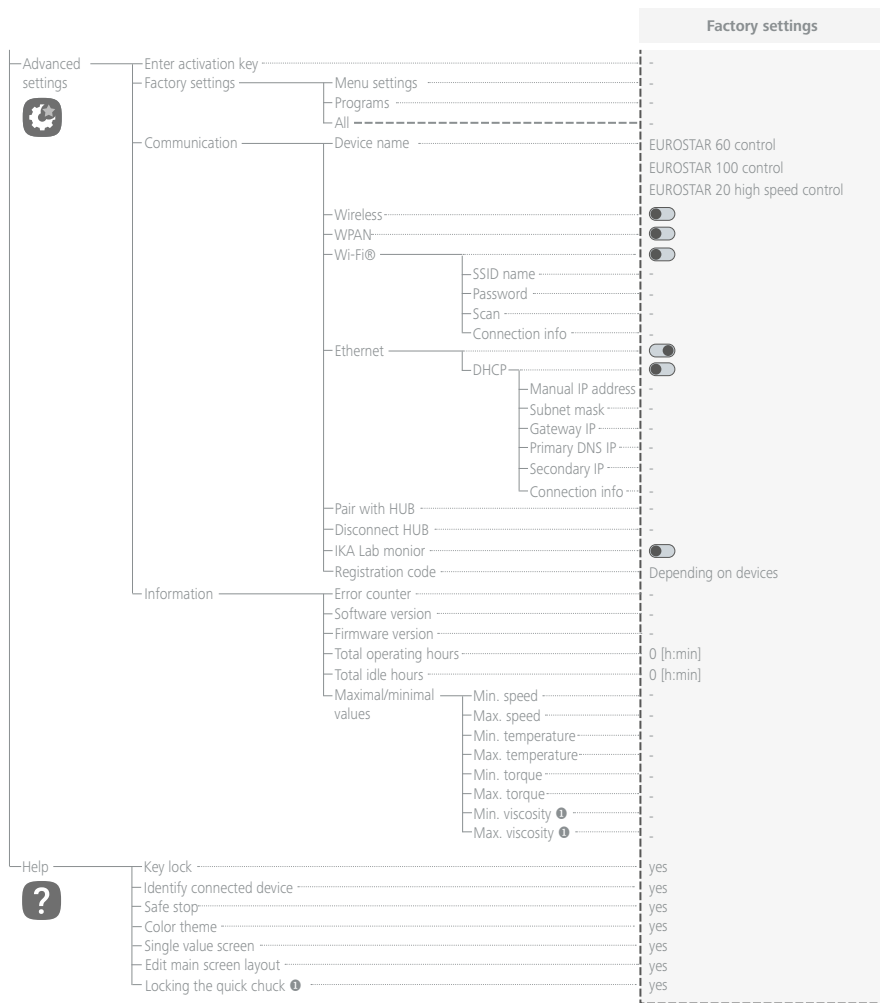

Note: Only for EUROSTAR 60/100 control.

/// Menu details

Stirring

Chaotic mixing:

In this menu option, you can activate chaotic mixing function.

EUROSTAR 60/100 control: The device changes the mixing directions and also the speed between 30 rpm and the set speed randomly.

EUROSTAR 20 high speed control: The device changes the speed between 150 rpm and the set speed randomly.

This chaotic mixing helps to increase the efficiency of mixing.

- i** > When the chaotic mixing function is activated, the torque value is shown as ---.
- > When the chaotic mixing function is activated, the intermittent mode is not available.

Soft start:

In this menu option, you can select "Slow", "Medium" or "Fast" for the starting.





Slow: The device slowly ramps to the set speed.

Medium: The device ramps to the set speed at a medium speed.

Fast: The device ramps to the set speed quickly.

Intermittent mode:

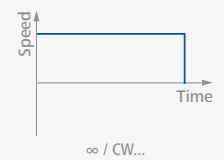

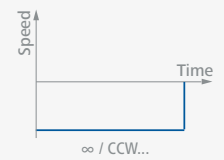





i In continuous mode, the device can rotate clockwise or counterclockwise.

Symbol rotation direction	Chuck rotation direction	Graph	
 CW (↻)			Clockwise: Continuous mode. Factory setting: clockwise.
 CCW (↺)			Counterclockwise: Continuous mode.

In "Intermittent mode" menu option, you can activate the intermittent mode by activating the "Run/Stop" function and meanwhile setting the "Run" time and "Stop" time under menu option "Set Interval".

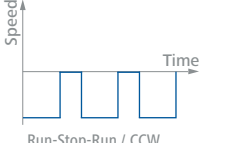
EUROSTAR 60/100 control: You can also activate the clockwise and counter-clockwise rotation function by activating the "CW/CCW" (Clockwise/Counterclockwise) menu option separately.

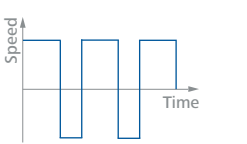
For details, see below information:

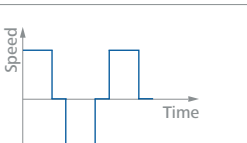
Symbol rotation direction	Chuck rotation direction	Graph	
 CW (↻)			Function "Run/Stop" is activated, clockwise: The run time and stop time can be set separately.
 CCW (↺)			Function "Run/Stop" is activated, counterclockwise: The "Run time" and "Stop time" can be set separately.
 CW (↻) / CCW (↺)			Function "CW/CCW" is activated: The clockwise and counterclockwise running time can be set independently by setting the "CW time" and "CCW time" under menu option "Set interval". Note: When the rotation direction switches between clockwise and counterclockwise, the device stops rotating for 5 seconds.
 CW (↻) / CCW (↺)			Functions "Run/Stop" and "CW/CCW" is activated: The "Run time" and "Stop time" can be set separately. Note: The run time is the same length in clockwise and counterclockwise direction.

i › When the intermittent mode is activated, the chaotic mixing function is not available.

1 Note: Only for **EUROSTAR 60/100 control**.

Torque calibration:

In this menu option, you can perform the torque calibration to the device. All torque resulting from bearing friction is excluded from the torque calculation. The torque calibration is performed without a mounted stirring tool. The calibration takes 25 seconds with 100 rpm for **EUROSTAR 60/100 control** and 1200 rpm for **EUROSTAR 20 high speed control**.

i › Keep the device vertically downward during torque calibration.
› The torque calibration needs to be done without load.

Chuck calibration (Only for **EUROSTAR 60/100 control**):

In this menu option, you can perform the chuck calibration after installing a new chuck to the device. All torque resulting from the chuck is excluded from the chuck calculation. The chuck calibration is performed without a mounted stirring tool. The calibration takes 25 seconds with 100 rpm.

i › Keep the device vertically downward during torque calibration.
› The torque calibration needs to be done without load.

1 Viscosity (Only for **EUROSTAR 60/100 control)**

Before measuring the viscosity, select a proper stirring tool according to the rough viscosity of the medium used.

Definition of the viscosity range:

	mPa·s	
VLV (Very Low Viscosity)	1 ... 100	Aqueous media
LV (Low Viscosity)	100 ... 1000	Light oil
MV (Medium Viscosity)	1000 ... 10000	Heavy oil
HV (High Viscosity)	10000 ... 100000	Pastes, creams

Check the measuring condition of the selected stirring tool in menu option "IKA measured conditions". Select appropriate ISO standard beaker and prepare required volume of medium according to the selected stirring tool.

Start measurement:

- › Remove the stirring tool from the device.
- › Perform warm-up to the device. The warm-up process lasts about 30 seconds.
- › Perform auto zeroing to the device. The auto zeroing process lasts about 30 seconds.
- › Select and check the set-up condition according to the stirring tool.
- › Install the selected stirring tool according to set-up condition.
- › Set speed according to the selected stirring tool and start viscosity measurement.

Note:

- › In order to get an accurate viscosity measuring, set up the stand on an even and level surface. Keep the device vertically downward during measuring. We recommend **R 2723** telescopic stand for viscosity measuring.
- › Reset the torque by touching button  on the working screen before placing the stirring tool into the medium.

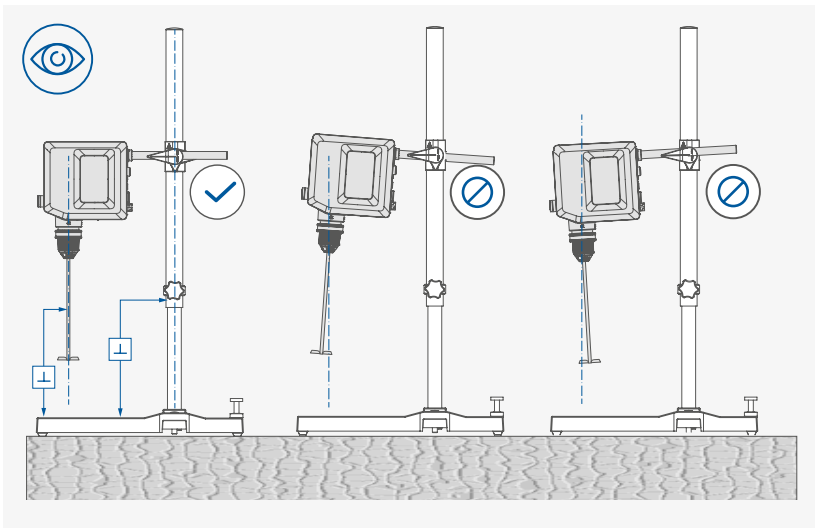
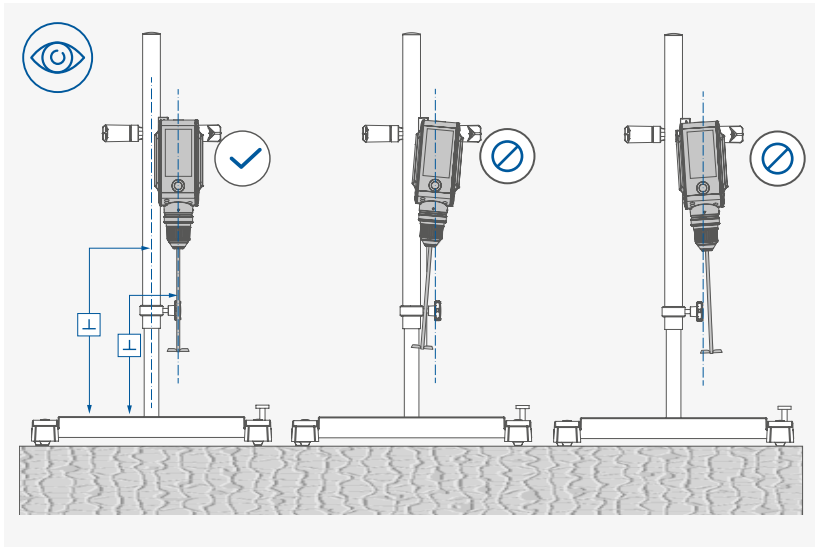

Stop viscosity measurement:

In this menu option, you can stop the viscosity measurement as below:

- › Pause the viscosity measurement by pressing the control knob.
- › Press menu button and enter viscosity menu option.
- › Press menu option "Stop viscosity measurement".
- › Confirm to stop the viscosity measurement.

Measuring condition:

› IKA measured condition:

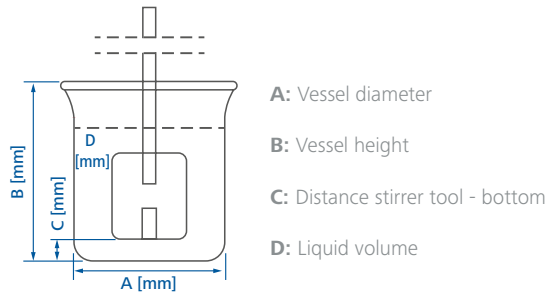

A: Vessel diameter

B: Vessel height

C: Distance stirrer tool - bottom

D: Liquid volume

Stirrer Tool	Image	Max. Speed [rpm]	A [mm]	B [mm]	C [mm]	D [ml]	Volume [ml]	Recommend Beaker Type	Optimum Speed [rpm]	Speed Range [rpm]	Max. Measuring Deviation
R 3004.1 LV		1000	80	153	10	500	600	TF 600 DIN EN ISO 3819 tall-form	500	100 ... 600	± 15 %
200									100 ... 600	± 12 %	
150									50 ... 350	± 8 %	
R 1313 LV		800	90	178	10	600	800	TF 800 DIN EN ISO 3819 tall-form	400	100 ... 600	± 8 %
400									100 ... 800	± 4 %	
200									50 ... 250	± 10 %	
R 1345 LV		800	120	244	20	1000	2000	TF 2000 DIN EN ISO 3819 tall-form	350	100 ... 500	± 16 %
200									100 ... 400	± 3 %	
200									50 ... 200	± 13 %	
R 1330 LV		1000	60	123	5	200	250	TF 250 DIN EN ISO 3819 tall-form	300	200 ... 600	± 16 %
300									200 ... 600	± 13 %	
200									100 ... 400	± 5 %	
R 1331 LV		1000	120	244	10	1700	2000	TF 2000 DIN EN ISO 3819 tall-form	250	100 ... 700	± 12 %
200									50 ... 400	± 3 %	
150									50 ... 300	± 4 %	
R 1375 LV		800	90	178	10	600	800	TF 800 DIN EN ISO 3819 tall-form	300	100 ... 500	± 6 %
200									100 ... 500	± 7 %	
100									50 ... 250	± 25 %	
R 1302 VLV		1000	150	214	10	1500	3000	TF 3000 DIN EN ISO 3819 tall-form	400	100 ... 800	± 10 %
300									100 ... 800	± 10 %	
350									100 ... 600	± 5 %	
100									50 ... 150	± 15 %	
R 1385 LV		800	150	214	10	1500	3000	TF 3000 DIN EN ISO 3819 tall-form	160	100 ... 200	± 15 %
300									50 ... 400	± 5 %	
100									50 ... 150	± 10 %	
R 3000.1 LV		1000	120	244	20	1000	2000	TF 2000 DIN EN ISO 3819 tall-form	200	100 ... 500	± 15 %
200									50 ... 400	± 3 %	
150									50 ... 200	± 30 %	
R 1376 LV		800	170	260	10	4000	5000	TF 5000 DIN EN ISO 3819 tall-form	100	50 ... 200	± 10 %
R 1376 MV									100	50 ... 200	± 10 %
LR 2000.11 LV		290	-	-	-	1200	2000	-	150	50 ... 250	± 20 %
LR 2000.11 MV									100	50 ... 290	± 8 %
LR 2000.11 HV									50	50	± 15 %
LR 2000.10 LV		290	-	-	-	1200	2000	-	50	50 ... 290	± 20 %
LR 2000.10 MV									100	50 ... 290	± 25 %
LR 2000.10 HV									50	50	± 15 %

› **User saved conditions:**

In this menu option, you can define the setup condition for your own stirring tools:

- Touch button [☰].
- Enter a name for the stirring tool and confirm it by touching button [✓].
- Remove the stirring tool as instruction on the screen and confirm by touching button [✓].
- Perform warm-up to the device or skip it by touching button [Skip].
- Perform auto zeroing to the device.
- Install your stirring tool and confirm it.
- Enter your setup conditions: Vessel diameter (A), Vessel height (B), Distance stirrer tool-bottom (C), Liquid volume (D), Minimum speed and Maximum speed value. And then confirm them by touching button [✓].

Note: To prevent splashing of the media, do not set too high maximum speed.

- Select three media of known viscosity. Enter their viscosities separately and perform calibration from low to high one by one. These three media viscosities for calibration measurement with the viscosity span not exceeding one order of magnitude, such as 100 to 1000 mPa·s, 500 to 5000 mPa·s, 1000 to 10000 mPa·s, 10000 to 100000 mPa·s.

Note: After calibrating the viscosity of a medium, make sure that the setup conditions remain unchanged. Also, wait for some time before calibrating the viscosity of next medium.

- Start simulation after calibrations are successfully finished.
- Save the stirring tool setup condition.

Density:

For easy conversion between different viscosity units, enter the density of the medium.

Note: Make sure to enter the medium density when using viscosity unit: cSt (Centistokes).



Temperature

In this menu option, you can perform connecting/disconnecting a wireless temperature sensor.

Note: For connecting the wireless temperature sensor, please firstly activate the WPAN function in menu option "Communication" under "Advanced settings".



Timer/Counter

In this menu option, you can select and activate timer or counter function for the device.

When the timer function is activated, you can activate alarm and/or stop menu options.

Once the set timer value has elapsed, the device give out an audio signal and/or stops running.

You can reset the time value by pressing the "Reset time".



Programs

My programs:

In this menu option, you can define up to 10 user-defined programs by touching the button [+].

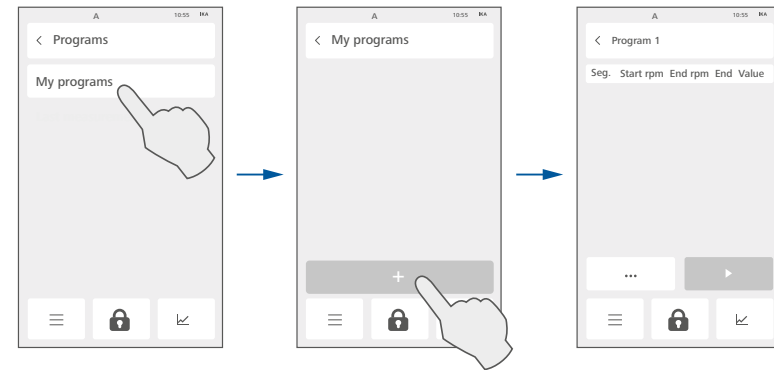

In every program, you can define up to 10 segments by touching the button [+].

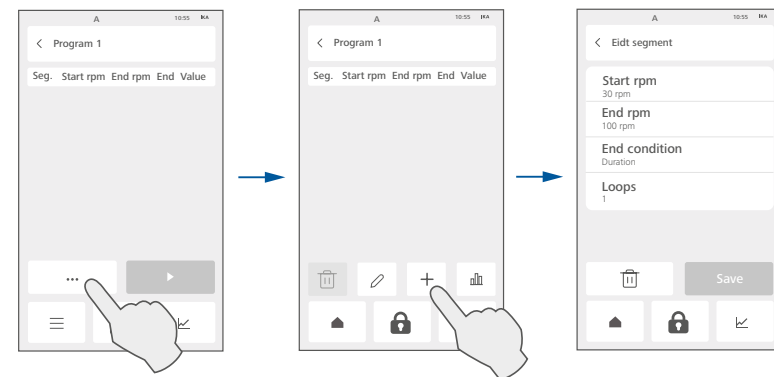

In every segment, you can define a "Start rpm", "End" speed, "End condition" and "Loops".

Start rpm: In this menu option, you can set a start speed in one segment.

End rpm: In this menu option, you can set an end speed rpm in one segment. The end value only applies if duration is selected in end condition.

End condition: In this menu option, you can select an end condition between "Duration", "Temperature" and "Torque" and set an end value in one segment. Once the device reaches the set end condition, device stops performing the next segments of the program.

Loops: In this menu option, you can set the number of loop cycles for the segment in the program.



- › When "Temperature" is selected as the end condition, the device must be connected to a temperature sensor to measure the temperature of the stirred medium.
- › The "Loops" setting is only available when the "Duration" is selected as the end condition.

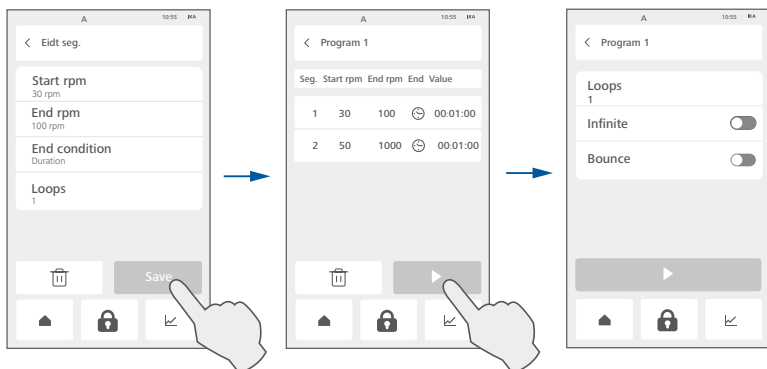

Save the settings by touching the button . Go to next screen to define the program “Loops”, “Infinite” and “Bounce” settings by touching the button . Start to run the program by touching the button .

Loops: In this menu option, you can set the number of loop cycles of the program.

Infinite: In this menu option, you can activate/deactivate the “Infinite” function.

When the “Infinite” function is activated, the program continues with the first segment after completion of the last segment until you end the program by stopping the device function.

Bounce: In this menu option, you can activate/deactivate the “Bounce” function.

When the “Bounce” function is activated, the device executes the program again from back to front after executing the program once.

i Explanation of the buttons function in the programs:	
	Create a new programs or a new segment in the program.
	Edit the selected segment in the program.
	Go to next screen or run the selected program.
	Delete the selected program segment or program.
	Rename the selected program.
	Save the settings in the program.
	Preview the graphs of the selected program.

Stop conditions

The device can stop or alarm based on temperature or torque thresholds.

Temperature:

In this menu option, you can set a lower and a higher limit value between 0 °C to 350 °C. Once the measured temperature value exceeds the set temperature range, the device will stop and/or give an alarm depending on the settings.

Torque:

In this menu option, you can set a torque limit value. Once the measured torque value exceeds the set torque value, the device will stop and/or give an alarm depending on the settings.

Safety

Time out:

In this menu, you can select 30 seconds, 2 minutes, 5 minutes or 10 minutes as the time limit. This time limit applies if there is a communication failure between the device and controller. The device will continue to run at the set speed until the set time has exceeded. If the communication failure time exceed the set time, the device will stop running or continue to run depending on the setting in below “Speed safe value”.

Speed safe value:

Off: In this menu option, you can deactivate the safe value function for the time out event. The device will stop running if the device and controller communication failure time exceed the time out setting.

Last set value: In this menu option, you can activate the last set value as the safe speed for the time out event.

The device will continue to run with last set speed if the device and controller communication failure time exceed the time out setting.

Safe speed: In this menu option, you can activate and set a value as the safe speed for the time out event.

The device will continue to run with the set speed if the device and controller communication failure time exceed the time out setting.

The default safe speed is 30 rpm (**EUROSTAR 60/100 control**) and 150 rpm (**EUROSTAR 20 high speed control**).

Vibration detection:

In this menu, you can activate/deactivate the vibration detection function. When the function is activated, you can select low sensitivity, medium sensitivity or high sensitivity for the device.

Low sensitivity (): The device can detect vigorous vibration.

Medium sensitivity (): The device can detect moderate vibration.

High sensitivity (): The device can detect minor vibration.

Speed limits:

In this menu, you can set a minimum and a maximum speed value for the device. The device speed can only be set within this range.

Torque limits:

In this menu, you can set desired maximum deliverable torque limit. The initial setting is the maximum permissible torque of the device. If the “Torque Limit” has been changed, the stirrer can deliver an operating torque only up to the value specified as the maximum torque limit.

Operation mode:

Mode A: After power on / power failure set value are not saved.

Mode B: After power on / power failure set value are saved.

Mode C: Set values cannot be changed. After power on / power failure set values are saved.

Setting for remote control:

In this menu, you can select "Device", "Controller" or "Both" as the leading device for remote control.



General settings

Languages:

In this menu option, you can select the desired language for the device.

Display:

Edit layout: In this menu option, you can edit the layout on the working screen.

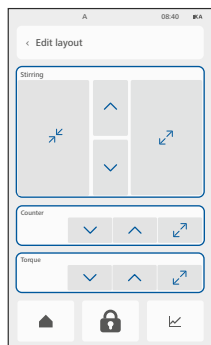

- > Touch button (↗) or (↖) to adjust the size of the selected value tile.
- > Touch button (↑) or (↓) to adjust the position of the selected value tile.



The layout of the values depend on the setting in menu option "Visible value".

Visible values: In this menu option, you can select and define "Timer/Counter", "Temperature" and "Torque" to be shown on the working screen.

Reset main screen layout: In this menu option, you can restore the main screen layout to factory setting.

Color theme: In this menu option, you can select "Dark" or "Light" color theme for the screen.

Brightness: In this menu option, you set the brightness for the screen.

Quick guide: In this menu option, you can activate/deactivate the quick guide during the device starting.

Sounds:

In this menu option, you can activate/deactivate the key tone and set the key tone volume.

Units:

In this menu option, you can select units for "Temperature", "Viscosity", "Torque" and "Density" as required.

Graph settings:

In this menu option, you can select 5 minutes, 10 minutes or 15 minutes as the time period for measurement data displayed in the graph.

Date & time:

In this menu option, you can adjust and set the date and time.

Auto standby:

In this menu option, you can select a time for auto standby for energy saving.



Advanced settings

Enter activation key:

In this menu option, you can upgrade your device to another model by entering the activation code. This is a paid service, please contact the IKA service department if you need it.

Factory settings:

In this menu option, you can restore the device to factory settings.

Menu settings: In this menu option, you can restore the menu settings to factory settings.

Programs: In this menu option, you can restore programs settings to factory settings.

All: In this menu option, you can restore all settings to factory settings.

Communication:

Device name: In this menu option, you can input and edit the device name with the keypad.

Wireless: In this menu option you can activate/deactivate the wireless (WPAN, Wi-Fi® and IKA Lab monitor) function.

WPAN: In this menu option, you can select and activate the WPAN function for connection an IKA device, e.g. ETS-D5.

WiFi®: In this menu option, you can select and activate the Wi-Fi function for communication. Scan and find available Wi-Fi and input the password for connecting a Wi-Fi.

Ethernet: In this menu option, you can select and activate the Ethernet function for communication.

Pair with HUB: In this menu option, you can make device discoverable by IKA HUB for scanning and connecting.

Note: For pairing with the IKA HUB, please firstly activate the WPAN function in menu option "Communication" under "Advanced settings".

Disconnect HUB: In this menu option, you can disconnect the device from IKA HUB.

IKA Lab monitor: In this menu option, you can activate/deactivate the IKA Lab monitor function. When the IKA Lab monitor function is activated, the device will connect with IKA lab monitor for recording the device operation with timestamp.

When the IKA Lab monitor function is deactivated, the device will disconnect with IKA lab monitor.

Registration code: The registration code is a unique code for each device and is used for the device registration.

Note: To connect the device with IKA lab monitor:

- Enable Wi-Fi settings and connect with the internet network.
- Register your device in IKA website: https://www.ika.com/owa/ika/myika.devices_reg and provide your device serial number and other details.
- Provide the registration code shown in your device.

Information:

In this menu option, you can view below informations:

Error counter: In this menu option, you can view error codes have occurred on your device.

Software version: In this menu option, you can view current software version in the device.

Firmware version: In this menu option, you can view the wireless module software version in the device.

Total operating hours: In this menu option, you can view the total operating hours of the device.

Total idle hours: In this menu option, you can view the total idle hours.

Maximal/minimal values: In this menu option, you view the minimum and the maximum values of speed, temperature, torque and viscosity.

? Help

In this menu option, you can find all available help topics.

Interfaces and outputs

The device can be operated in "Remote" mode via the RS 232 port / USB port or ethernet port connected to a PC and with the laboratory software Labworldsoft®.

The device can also be operated/read out via a wireless connection.

The device software can also be updated with a PC via the RS 232 port / USB port or ethernet port.

⚠ Notice!

Please comply with the system requirements together with the operating instructions and help section included with the software.

Also note the requirements for the ability to put the device into a safe status in an emergency if it is controlled externally.

/// USB interface

The Universal Serial Bus (USB) is a serial bus for connecting the device to the PC. Equipped with USB devices can be connected to a PC during operation (hot plugging).

Connected devices and their properties are automatically recognized.

/// USB device drivers

Connect the IKA device through the USB data cable to the PC. The data communication is via a virtual COM port.

From Windows 10 and onwards the standard Windows USB driver is automatically loaded and a COM port number is assigned (find details in Windows Device Manager: "USB Serial Port (COMxx)"). If you have problems with USB communication, first ask your IT system administrator whether access to the USB interface is restricted for data security reasons.

/// Ethernet

After connecting the device to the router or PC via the Ethernet cable, the correct IP address should be entered.

If the DHCP protocol is enabled, the IP address is assigned automatically. If not, the user should enter it manually. The IP port number is fixed at 40812.

/// RS 232 interface

Configuration:

- ▶ The functions of the interface connections between the device and the automation system are chosen from the signals specified in EIA standard RS 232 in accordance with DIN 66 020 Part 1.
- ▶ For the electrical characteristics of the interface and the allocation of signal status, standard RS 232 applies in accordance with DIN 66 259 Part 1.
- ▶ Transmission procedure: asynchronous character transmission in start-stop mode.
- ▶ Type of transmission: full duplex.
- ▶ Character format: character representation in accordance with data format in DIN 66 022 for start-stop mode. 1 start bit; 7 character bits; 1 parity bit (even); 1 stop bit.
- ▶ Transmission speed: 9600 bit/s.
- ▶ Data flow control: none
- ▶ Access procedure: data transfer from the device to the computer takes place only at the computer's request.

/// Command syntax and format

The following applies to the command set:

- ▶ Commands are generally sent from the computer to the lab device.
- ▶ The lab device only sends at the computer's request. Even fault indications cannot be sent spontaneously from the lab device to the computer (automation system).
- ▶ Commands are transmitted in capital letters.
- ▶ Commands and parameters including successive parameters are separated by at least one space (Code: hex 0x20).
- ▶ Each individual command (incl. parameters and data) and each response are terminated with CR LF (Code: hex 0x0d hex 0x0A) and have a maximum length of 80 characters.
- ▶ The decimal separator in a number is a dot (Code: hex 0x2E).

The above details correspond as far as possible to the recommendations of the NAMUR working party (NAMUR recommendations for the design of electrical plug connections for analogue and digital signal transmission on individual items of laboratory control equipment, rev. 1.1).

The NAMUR commands and the additional specific IKA commands serve only as low level commands for communication between the device and the PC. With a suitable terminal or communications program these commands can be transmitted directly to the device. The IKA software Labworldsoft®, provides a convenient tool for controlling the device and collecting data under MS Windows, and includes graphical entry features, e.g. the motor speed ramps.

Commands	Function
IN_NAME	Read device name.
IN_PV_4	Read current speed value.
IN_PV_5	Read current torque value.
IN_SP_4	Read rated speed value.
IN_SP_5	Read the torque limit value.
IN_SP_6	Read the speed limit value.
IN_SP_8	Read the safety speed value.
OUT_SP_4 X	Adjust the rated speed value to X.
OUT_SP_5 X	Adjust the torque limit value to X.
OUT_SP_6 X	Adjust the speed limit value to X.
OUT_SP_8 X	Adjust the safety speed value to X.
START_4	Start the motor.
STOP_4	Stop the motor.
RESET	Switch to normal operating mode.

/// Connections between device and external devices

› Connecting device to a PC:

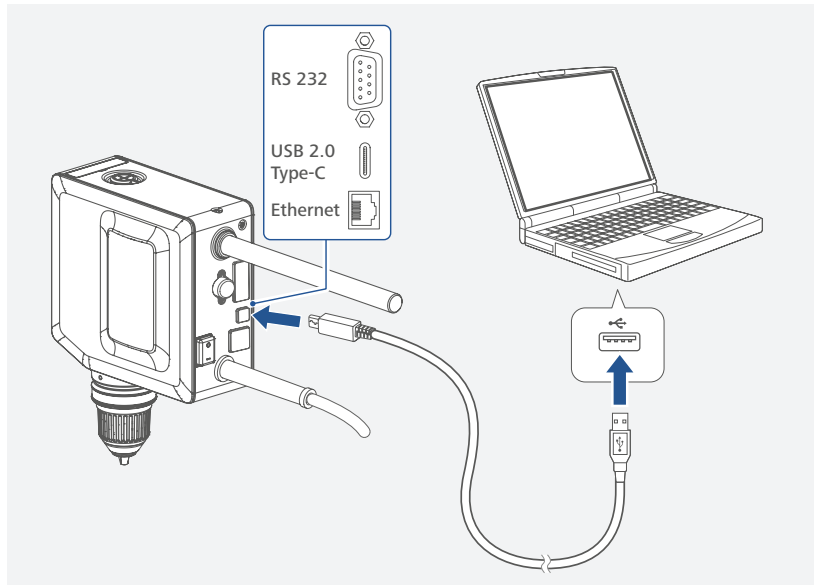

Ethernet cable (RJ45):

This cable is required to connect ethernet interface to a PC.



› Wireless connection:

For details on setting up a wireless connection, please refer to the relevant operating instructions.

/// Device software update

Keep your device up-to-date with the IKA Firmware update tool.

The firmware update can be done with a computer connected through USB-Interface.

For this, you need register on our website MyIKA first.

After registering your device IKA will inform you about available updates for your devices.

Please download the software "FWUToolSetup.zip" from our IKA service website www.ika.com.

PC 1.1 Cable:

This cable is required to connect RS 232 interface to a PC.

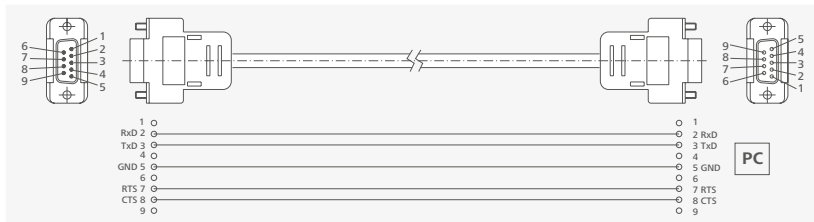

USB 2.0 cable (A - C):

This cable is required to connect USB interface to a PC.

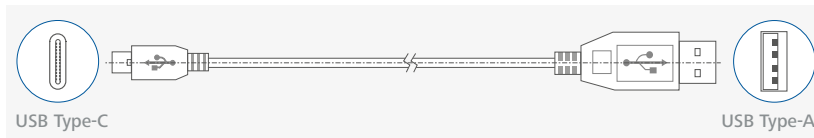

Maintenance and cleaning

The device is maintenance-free. It is only subject to the natural wear and tear of components and their statistical failure rate.

/// Cleaning

For cleaning disconnect the mains plug!

Use only cleaning agents which have been approved by IKA to clean the device: water containing surfactant / isopropyl alcohol.

- › Wear protective gloves during cleaning the devices.
- › Electrical devices may not be placed in the cleansing agent for the purpose of cleaning.
- › Do not allow moisture to get into the device when cleaning.
- › Before using another than the recommended method for cleaning or decontamination, the user must ascertain with IKA that this method does not destroy the device.

/// Spare parts order

When ordering spare parts, please give:

- › Machine type
- › Serial number, see type plate
- › Item and designation of the spare part, see: www.ika.com, spare parts diagram and spare parts list.
- › Software version (Briefly visible in the display when the device is switched on).

/// Repair

Please send in device for repair only after it has been cleaned and is free from any materials which may constitute a health hazard.

For repair, please request the "Decontamination Certificate" form IKA or use the download printout of it from IKA website: www.ika.com.

If you require servicing, return the device in its original packaging. Storage packaging is not sufficient. Please also use suitable transport packaging.

Troubleshooting (Only for EUROSTAR 60/100 control)

If the locking ring is in the upper position, the device is locked. The chuck symbol appears on the screen. The device function cannot be started when the device is locked.

When the locking ring is in the lower position, the device is unlocked. The device is ready for operation in this state and can be restarted by pressing the control button (J).

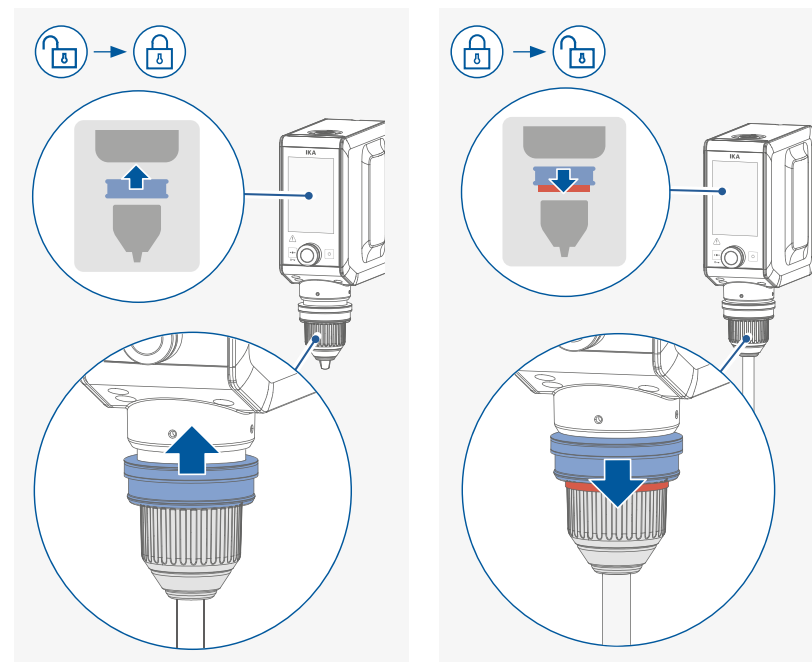

In some cases it can happen that:

- › The device display does not show the chuck symbol, e.g. under the influence of a magnetic field, although the locking ring is in the locked position or
- › After replacing the quick sense keyless chuck, the device display still shows the chuck symbol even though the locking ring is in the unlocked position.

If above mentioned situations occur, follow these steps:

Remove the fitted stirring tools. Make sure that the locking ring is in the unlocked position. Then, perform chuck calibration.

Error codes

Any malfunctions during operation will be identified by a warning or error message on the display. Carry out corrective measures accordingly.

Error code | Causes | Effect | Solutions

Error code 03: Communication

Error code: 15030123 - Communication WPAN out of range

Cause	› Wireless signal is too weak.
Effect	› Motor off or not depending on the setting
Solution	› Keep the device within the allowed wireless range.

Error code: 15030607 - Communication contact timeout

Cause	› Main micro controller unit and sub micro controller unit can't communicate with each other.
Effect	› Motor off
Solution	› Switch off the device. › Restart the device.

Error code: 15031107 - Communication Ethernet timeout

Cause	› No Ethernet communication with the external control unit. Watchdog timeout occurred.
Effect	› Motor off or not depending on the setting
Solution	› Check the Ethernet connection to the external control unit.

Error code: 15032507 - Communication RS 232 timeout

Cause	› No RS 232 communication with the external control unit. Watchdog timeout occurred.
Effect	› Motor off or not depending on the setting
Solution	› Check the RS 232 connection to the external control unit.

Error code: 15034107 - Communication USB timeout

Cause	› No USB communication with the external control unit. Watchdog timeout occurred.
Effect	› Motor off or not depending on the setting
Solution	› Check the USB connection to the external control unit.

Error code: 15034307 - Communication Wi-Fi timeout

Cause	› No Wi-Fi communication with the external control unit. Watchdog timeout occurred.
Effect	› Motor off or not depending on the setting
Solution	› Check the Wi-Fi connection to the external control unit.

Error code 24: Motor

Error code: 15240702 - Motor current upper limit exceeded

Cause	› Motor blockage or overload.
Effect	› Motor off
Solution	› Switch off the device. › Decrease the load on the motor and restart device again.

Error code: 15242309 - Motor PCB shutdown

Cause	› Motor driving protection circuit trigger.
Effect	› Motor off
Solution	› Switch off the motor and restart the device.

Error code: 15242920 - Motor sensor fault

Cause	› The position sensor in the motor is defective. Loose cable or incorrect rotor position.
Effect	› Motor off
Solution	› Stop stirring. Restart the device.

Error code: 15243802 - Motor temperature upper limit exceeded

Cause	› Temperature inside of the device is too high.
Effect	› Motor off
Solution	› Switch off the device and let it cool down.

Error code: 15244204 - Motor voltage permitted deviation exceeded.

Cause	› The voltage for the motor is too high or too low.
Effect	› Motor off
Solution	› Stop the device, restart it, and check the stirrer, liquid, and container before putting it back into operation.

Error code 27: PCB

Error code: 15270008 - PCB safety circuit cut-off

Cause	› Safety hardware trigger.
Effect	› Motor off
Solution	› Stop stirring. Restart the device.

Error code 29: Power supply

Error code: 15294202 - Power supply voltage upper limit exceeded

Cause	› AC input voltage is too high.
Effect	› Motor off
Solution	› The device operates at 100 VAC ~ 240 VAC.

Error code: 15294204 - Power supply voltage permitted deviation exceeded

Cause	› AC input voltage is too low.
Effect	› Motor off
Solution	› The device operates at 100 VAC ~ 240 VAC.

Error code 41: Internal temperature

Error code: 15411003 - Internal temperature driver upper limit exceeded.

Cause	› The circuit board temperature is too high.
Effect	› Motor off
Solution	› Stop stirring. Switch off the device and let it cool down.

Error code 47: Vibration

Error code: 15472919 - Vibration sensor free fall detected

Cause	› The device has fallen down.
Effect	› Motor off
Solution	› Fasten the device securely and restart the device.

Error code: 15470024 - Vibration too high

Cause	› The vibration of the device is higher than the permissible value.
Effect	› Motor off
Solution	› Disable vibration detection. Make adjustments to correct the conditions causing excessive vibration.

Error code 64: Chuck

Error code: 15642920 - Chuck sensor fault

Cause	› The chuck has been damaged or there is something with a strong magnetic field near the chuck.
Effect	› Motor off
Solution	› Check the chuck and remove anything with a strong magnetic field.

If the actions described fails to resolve the fault or another error code is displayed then take one of the following steps:

- › Contact the service department
- › Send the device for repair, including a short description of the fault.

Accessories

R 2722	H-stand	H 66.51	Temperature sensor, glass-coated
R 2723	Telescopic stand	H 66.53	Temperature sensor, non-stick coating based on perfluoroalkoxy and polytetrafluoroethylene
R 270	Cross sleeve	H 67.60	Temperature sensor, stainless steel
R 271	Cross sleeve	H 67.61	Temperature sensor, stainless steel
RH 5	Strap clamp	H 68.55	Temperature sensor, stainless steel
FK 1	Flexible coupling	H 71.32	Temperature sensor, PTFE-coated
R 401	Stirrer shaft protector	H 71.45	Temperature sensor, PTFE-coated
PC 1.1	Cable	USB 2.0 cable (A – C)	
H 70	Extension cable		
H 62.51	Stainless steel sensor		

See more accessories on www.ika.com.

Permitted IKA stirrer tools

	Max. Speed (rpm)
R 1342 Propeller stirrer	≤ 2000
R 1345 Propeller stirrer	≤ 800
R 1381 Propeller stirrer	≤ 2000
R 1382 Propeller stirrer	≤ 2000
R 1389 Propeller stirrer, PTFE	≤ 800
R 1311 Turbine stirrer	≤ 2000
R 1312 Turbine stirrer	≤ 2000
R 1313 Turbine stirrer	≤ 800
R 1300 Dissolver stirrer	≤ 2000
R 1302 Dissolver stirrer	≤ 1000
R 1303 Dissolver stirrer	≤ 2000
R 1352 Centrifugal stirrer	≤ 2000
R 1355 Centrifugal stirrer	≤ 800
R 1375 Paddle stirrer	≤ 800
R 1330 Anchor stirrer	≤ 1000
R 1331 Anchor stirrer	≤ 1000
R 3000.1 Moebius stirrer	≤ 800
R 3001.1 Moebius stirrer	≤ 800
R 3003 Spiral stirrer	≤ 800
R 3003.1 Spiral stirrer	≤ 800
R 3004 Blade stirrer	≤ 1000
R 3004.1 Blade stirrer	≤ 1000
R 3004.2 Blade stirrer	≤ 1000
R 6000 Precision shaft ^①	≤ 6000
R 1401 Propeller ^②	≤ 6000
R 1402 Dissolver ^②	≤ 6000
R 1405 Propeller ^②	≤ 6000
R 1406 Cup impeller ^②	≤ 4000

See more permitted on www.ika.com.



^{①/②} Only for **EUROSTAR 20 high speed control**.

^② Only be used in conjunction with **R 6000** precision shaft.



Technical Data

		EUROSTAR 60 control	EUROSTAR 100 control	EUROSTAR 20 high speed control
Speed range under nominal load	rpm	0/30 ... 2000	0/30 ... 2000	0/150 ... 6000
Speed adjustment		Stepless		
Speed display		TFT		
Speed setting accuracy	rpm	± 1		
Speed measurement deviation		Speed < 300 rpm: ± 3 rpm / Speed > 300 rpm: ± 1 %		
Max. torque at stirrer shaft (see section "Torque graph")	Ncm	100 (at 30 ... 400 rpm)	200 (up to 20 minutes ^①) (at 30 ... 600 rpm)	40 (at 150 ... 600 rpm)
			120 (at 30 ... 600 rpm)	
		100 ... 60 (at 400 ... 2000 rpm)	120 ... 100 (at 600 ... 1300 rpm)	40 ... 20 (at 600 ... 6000 rpm)
			100 ... 60 (at 1300 ... 2000 rpm)	
Torque trend measurement		Yes		
Torque trend display		Yes		
Torque measurement deviation	Ncm	± 1		
Max. stirring quantity (water)	l	60	100	20
Max. viscosity	mPa·s	50000	70000	10000
Intermittent operation		Yes		
Reversible direction of rotation		Yes	Yes	No
Port for external temperature sensor		Yes		
Temperature measurement resolution	K	0.1		
Temperature measurement range	°C	-10 ... 350		
Limiting deviation, temperature sensor Pt 1000 DIN EN 60751 class A	K	≤ ± (0.15 + 0.002 x ITI)		
Temperature measurement accuracy	K	± 0.5 + tolerance PT 1000 (DIN EN 60751 class A)		
Temperature display		Yes		
Temperature display resolution	K	0.1		
Timer/Counter function		Yes		
Timer/Counter display		TFT		
Max. Timer/Counter		100 hours (99:59:59 [hour:minute:second])		
Permitted on time	%	100		
Nominal voltage	VAC	100 ... 230		
Frequency	Hz	50/60		
Max. input power	W	168	186	176
Max. output power at stirring shaft	W	131	136	125
Noise level without stirring tool	dB (A)	52	52	-
Interface		USB, RS 232, Ethernet		

		EUROSTAR 60 control	EUROSTAR 100 control	EUROSTAR 20 high speed control
IP code according to EN 60529		IP 54		
Protection class		I		
Overvoltage category		II		
Contamination level		2		
Protection at overload		Yes / motor current limitation		
Permissible ambient temperature	°C	5 ... 40		
Permissible relative humidity	%	80		
Drive		Brushless motor		
Clamping chuck-clamping range	mm	0.5 ... 10	0.5 ... 10	②
Hollow shaft internal diameter	mm	11	11	-
Housing		Coated aluminum casting and thermoplastic plastic		
Extension arm (Ø x L)	mm	16 x 220		
Dimensions (W x D x H) (without extension arm)	mm	89 x 191 x 237	89 x 191 x 237	89 x 191 x 306
Weight (with extension arm and clamping chuck)	kg	3.9	3.9	5.2
Operation at a terrestrial altitude	m	max. 2000		

Subject to technical changes!



- ① Up to 20 minutes, depending on room temperature and voltage etc..
- ② Conical attachment for precision shaft **R 6000**, screw on stirring tool (e.g. **R 1401**).

Warranty

In accordance with IKA Terms and Condition of sale, the warranty period is 24 months. For claims under the warranty please contact your local dealer. You may also send the machine direct to our factory, enclosing the delivery invoice and giving reasons for the claim. You will be liable for freight costs.

The warranty does not cover worn out parts, nor does it apply to faults resulting from improper use, insufficient care or maintenance not carried out in accordance with the instructions in this operating manual.

Torque graph

EUROSTAR 60 control

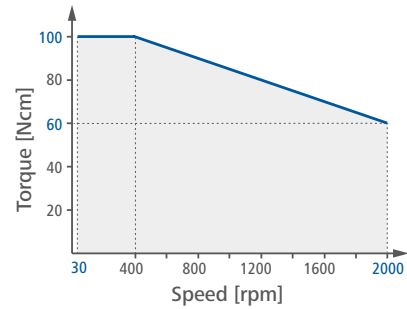

EUROSTAR 100 control

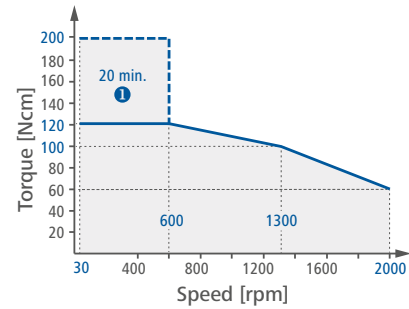

Note: Up to 20 minutes, depending on room temperature and voltage etc..

EUROSTAR 20 high speed control

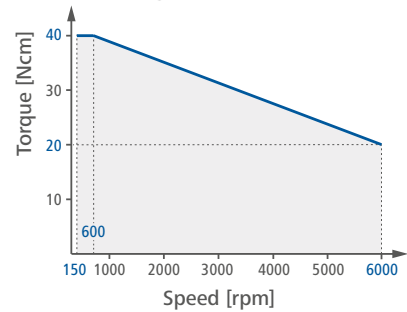



designed for scientists

IKA-Werke GmbH & Co. KG

Janke & Kunkel-Straße 10, 79219 Staufen, Germany
Phone: +49 7633 831-0, Fax: +49 7633 831-98
eMail: sales@ika.de

USA

IKA Works, Inc.
Phone: +1 910 452-7059
sales@ika.net

KOREA

IKA Korea Ltd.
Phone: +82 2 2136 6800
sales-lab@ika.kr

BRASIL

IKA Brasil
Phone: +55 19 3772-9600
sales@ika.net.br

MALAYSIA

IKA Works (Asia) Sdn Bhd
Phone: +60 3 6099-5666
sales.lab@ika.my

CHINA

IKA Works Guangzhou
Phone: +86 20 8222 6771
info@ika.cn

POLAND

IKA Poland Sp. z o.o.
Phone: +48 22 201 99 79
sales.poland@ika.com

JAPAN

IKA Japan K.K.
Phone: +81 6 6730 6781
info_japan@ika.ne.jp

INDIA

IKA India Private Limited
Phone: +91 80 26253 900
info@ika.in

UNITED KINGDOM

IKA England LTD.
Phone: +44 1865 986 162
sales.england@ika.com

VIETNAM

IKA Vietnam Company Limited
Phone: +84 28 38202142
sales.lab-vietnam@ika.com

THAILAND

IKA Works (Thailand) Co. Ltd.
Phone: +66 2059 4690
sales.lab-thailand@ika.com

TURKEY

IKA Turkey A.S
Phone: +90 216 394 43 43
sales.turkey@ika.com

KENYA

IKA Works Kenya Ltd.
Phone: +254 112 323 745
sales.kenya@ika.com

UGANDA

IKA Works Kampala Limited
Phone: +254 112 323 745
sales.uganda@ika.com

SPAIN

IKA Works Spain, S. L.
Barcelona
sales.spain@ika.com

Discover and order the fascinating products of IKA online:
www.ika.com



IKAworldwide



IKAworldwide /// #lookattheblue



@IKAworldwide
