

foodproof[®]

Salmonella Detection LyoKit

PRODUCT INSTRUCTIONS

Documentation for the qualitative detection of *Salmonella* spp.

Product No. KIT230099 / KIT230100 / KIT230101 / KIT230102

foodproof®
Salmonella
Detection LyoKit

Product No.

LP: KIT230099

RP: KIT230101

DP: KIT230102

Kit for 96 reactions (lyophilized)
for a maximum of 94 samples

LP: KIT 230100

Kit for 480 reactions (lyophilized)
for a maximum of 470 samples

Store kit at 2 to 8 °C

For testing of food
and environmental samples

Approvals:



PRODUCT INSTRUCTIONS

Revision A, September 2023

TABLE OF CONTENTS

1. OVERVIEW 4

1.1 General Information 4

1.2 Applicability..... 4

1.3 Kit Contents 5

2. INSTRUCTIONS 7

2.1 Required Material 7

2.2 Precautions and Preparations..... 8

2.3 Enrichment and DNA Extraction 9

 2.3.1 Certified Methods 9

2.4 Procedure 11

 2.4.1 Workflow 11

 2.4.2 Program Setup..... 12

 2.4.3 Data Interpretation 12

2.5 Troubleshooting 13

2.6 Support..... 14

3. ADDITIONAL INFORMATION 15

3.1 Testing Principle 15

3.2 Trademarks 16

3.3 Reference Number 16

3.4 Change Index 16

OVERVIEW

1. OVERVIEW

1.1 General Information

Number of Reactions

The kit is designed for 96 reactions or 480 reactions respectively with a final reaction volume of 25 µL each. Up to 94 samples or 470 samples (single sample preparation) plus positive and negative control can be analyzed per run.

Storage and Stability

Store all components at 2 to 8 °C. They are guaranteed to be stable through the expiration date printed on the label. Opening of the kit does not shorten the expiration date. The PCR strips must be stored in the provided aluminum bag. Protect from light and moisture.

LyoKit Tube Profiles

The LyoKit is available in three different tube profiles: white low profile tubes, 0.1 mL (LP), clear regular profile tubes, 0.2 mL (RP) and clear low profile tubes, 0.1 mL (DP).

The majority of real-time PCR cyclers use low profile tubes, 0.1 mL (LP). For the Dualo 32[®] R2 and a few other cyclers, please use clear low profile tubes, 0.1 mL (DP). For a detailed overview, please reference our compatibility chart.

1.2 Applicability

The foodproof[®] *Salmonella* Detection LyoKit is intended for the rapid detection of *Salmonella* spp. isolated from enrichment cultures by using the DNA extraction methods above for all relevant kinds of foods, feeds, environmental samples and samples from the primary production stage (PPS) that are potentially contaminated with *Salmonella*. The foodproof *Salmonella* Detection LyoKit is intended for the food and feed industry and for food testing laboratories. The limit of detection is 1 – 10 cfu / 25 g sample.

The kit described in this Instruction Manual has been developed for real-time PCR instruments with a FAM and a VIC detection channel. The performance of the kit was tested with the following real-time PCR instruments: LightCycler[®] 480, LightCycler[®] 96 (Roche Diagnostics), Mx3005P[®] (Agilent Technologies), and Applied Biosystems[™] 7500 Fast (Thermo Scientific).

The kit must not be used in diagnostic procedures.

OVERVIEW

1.3 Kit Contents

A schematic representation of the foodproof *Salmonella* Detection LyoKit with all its components.

LP: KIT230099

RP: KIT230101

DP: KIT230102

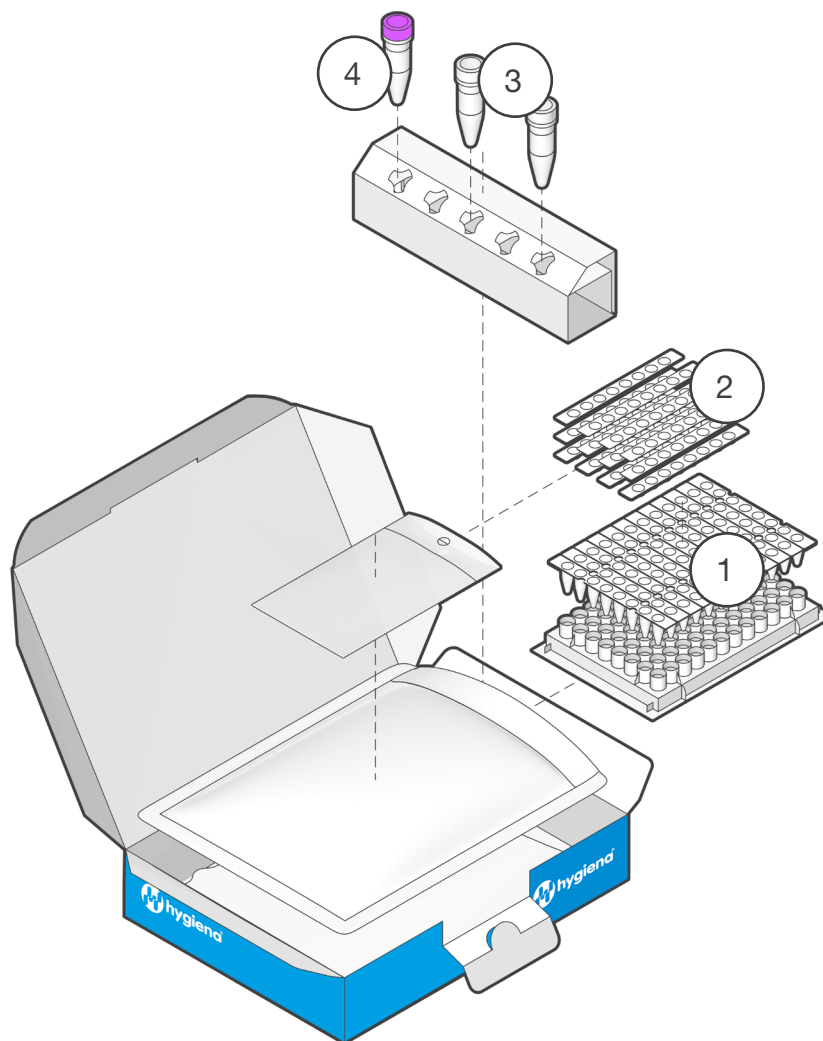

	Component	Details
1	Microplate	12 x 8-tube strips, prefilled with lyophilized ready-to-use PCR mix. Three different tube profiles are available: white low profile tubes (LP), clear regular profile tubes (RP) and clear low profile tubes (DP).*
2	12 x 8-cap strips	For use in real-time PCR after addition of samples.
3	2 x H ₂ O PCR-grade (colorless cap)	1 mL nuclease-free, for use as a PCR run negative control.
4	Control Template (purple cap)	900 µL, contains a stabilized solution of DNA for use as a PCR run positive control.

* Tube profile and instrument compatibility chart is available online

OVERVIEW

LP: KIT230100

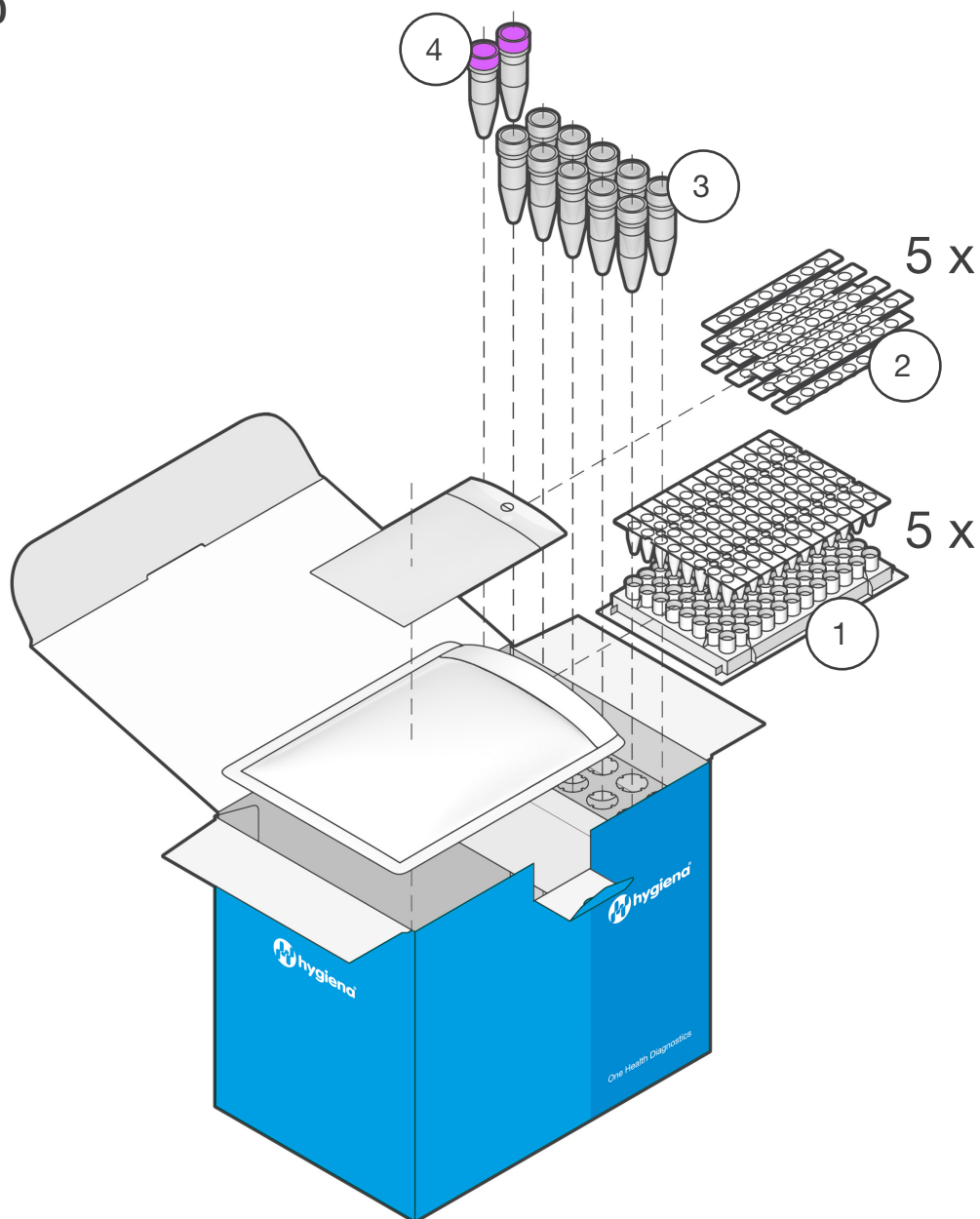

	Component	Details
1	5 x Microplate	12 x 8-tube strips, prefilled with lyophilized ready-to-use PCR mix. Available as white low profile tubes (LP).*
2	5 x Bag Cap Strips	12 x 8-cap strips, for use in real-time PCR after addition of samples.
3	10 x H ₂ O PCR-grade (colorless cap)	1 mL nuclease-free, for use as a PCR run negative control.
4	2 x Control Template (purple cap)	500 µL, contains a stabilized solution of DNA for use as a PCR run positive control.

* Tube profile and instrument compatibility chart is available online

INSTRUCTIONS

2. INSTRUCTIONS

2.1 Required Material

Most of the required equipment and reagents are available through Hygiena®. Please contact us for further information.



Use a real-time PCR cycler suitable for detection of respective probes as well as for using low or regular profile strip tubes.

In case the strip tubes don't fit for the instrument, the samples should be transferred to appropriate PCR vessels after resuspension of the lyophilized PCR mix.

Material

- Nuclease-free, aerosol-resistant pipette **filter tips**.



- PCR strip or plate centrifuges**

- *Without vortex: Mini microcentrifuge for 4 x 8-strips*
- *With vortex: Multispin MSC-6000 for 4 x 8-strips*
- *With vortex: CVP-2 for 12 x 8-strips and plates*

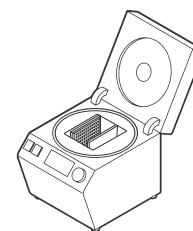

- DNA extraction kits**

- *foodproof StarPrep One (KIT230175 - 100 reactions; KIT230176 - 500 reactions) or*
- *foodproof StarPrep Three (KIT 230187) or*
- *foodproof Magnetic Preparation Kit I (KIT 230180)*

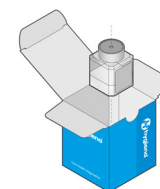

INSTRUCTIONS

2.2 Precautions and Preparations

The kit provides all reagents required for the PCR. However, in order to achieve reliable results, the entire assay procedure must be performed under nuclease-free conditions. Follow the instructions below to avoid nucleases, carry-over or cross-contamination:

- Keep the kit components separate from other reagents in the laboratory.
- Use nuclease-free labware (e.g., pipettes, pipette tips, reaction vials).
- Wear gloves when performing the assay.
- To avoid cross-contamination of samples and reagents, use fresh aerosol barrier pipette tips.
- To avoid carry-over contamination, transfer the required solutions for one experiment into a fresh tube, rather than directly pipetting from stock solutions.
- Physically separate the workplaces for DNA preparation, PCR setup and PCR to minimize the risk of carry-over contamination. Use a PCR hood for all pipetting steps.
- Sample Material:** Use any sample material suitable for PCR in terms of purity, concentration and absence of inhibitors.
- DNA Extraction:** We provide sample preparation kits suitable for all kind of food and other samples.
- Positive Control:** Always run a positive control with the samples. Use the provided control DNA (Control Template) or a positive sample preparation control.
- Negative Control:** Always run a negative control with the samples. To prepare a negative control, replace the template DNA with PCR-grade water. Include a negative control during sample preparation to monitor reaction purity and cross-contamination. This extraction control can be used as an additional negative control reaction.
- Confirmation:** If required, positive results may be confirmed by appropriate methods (e.g., reference method).
- Waste Disposal:** All contaminated and potentially infectious material, like enrichment cultures or food samples, should be autoclaved before disposal and eliminated according to local rules and regulations. For more information, e.g., proper disposal of unused chemicals, please refer to the appropriate safety data sheet (SDS).



Keep the PCR mix away from light and moisture.

For more information, please refer to the appropriate safety data sheet (SDS). The SDS is available online at www.hygiena.com/sds.

INSTRUCTIONS

2.3 Enrichment and DNA extraction

The foodproof *Salmonella* Detection LyoKit is intended for the rapid detection of *Salmonella* spp. DNA isolated from enrichment cultures. For DNA extraction, please use the kits mentioned in 2.1 Required Material.

2.3.1 Certified Methods

The foodproof *Salmonella* Detection LyoKit is AOAC RI *Performance Tested Methods*SM program validated (License no. 120301) for a variety of foods including: custard, ground beef, chocolate ice cream, mayonnaise, pet food, primary production stage samples (boot socks with environmental material).

Furthermore, the foodproof *Salmonella* Detection LyoKit in combination with the foodproof Magnetic Preparation Kit I (KIT230180) for automated sample preparation and the foodproof StarPrep One Kit (KIT230175) for manual sample preparation is validated according to ISO 16140-2 by MicroVal studies (2011LR40 and 2011LR42). The validation was done with the following food categories: fish and seafood products, chocolate and bakery products, egg products, feed samples, meat and meat products, milk and dairy products and primary production stage samples (PPS). The extension of the *Salmonella* detection method for the foodproof *Salmonella* Detection LyoKit was done with the following PCR instruments: CFX96™ from Bio-Rad (software version CFX Manager 2.0) and LightCycler® 480 II (software version 1.5.1) from Roche.

INSTRUCTIONS

In the table below an overview is shown how the samples were processed within the validation studies.

Protocols MicroVal projects 2011LR40 / 2011LR42 - foodproof *Salmonella* Detection LyoKit

Category*	Enrichment	Second enrichment	DNA extraction	Confirmation
Meat and meat products/ milk and dairy products/egg products/feed samples/ fish and seafood products	25 g + 225 mL BPW for 20 ± 2 h at 37 ± 1 °C	none	foodproof StarPrep One	according EN ISO 6579-1:2017
Cocoa and cocoa-containing products	25 g + 225 mL skimmed milk + Brilliant Green for 20 ± 2 h at 37 ± 1 °C	none	foodproof StarPrep One	according EN ISO 6579-1:2017
Meat and meat products/ milk and dairy products/egg products/feed samples/ fish and seafood products	25 g + 225 mL BPW for 19 - 20 h at 37 ± 1 °C	none	foodproof Magnetic Preparation Kit I	according EN ISO 6579-1:2017
PPS	25 g + 225 mL BPW (preheated) for 16 - 20 h at 37 ± 1 °C	0.1 mL + 10 mL RVS broth 16 - 24 h at 41.5 ± 1 °C	foodproof StarPrep One on 500 µL enrichment culture	according EN ISO 6579-1:2017

*Preparation of test samples according to the appropriate part of ISO 6887.

INSTRUCTIONS

2.4 Procedure

This protocol describes how to perform the analysis of DNA extracts by real-time PCR.

2.4.1 Workflow

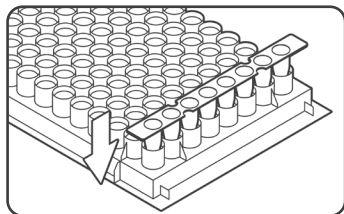

1. PLACE STRIPS IN RACK

Take needed number of PCR tube strips out of aluminum bag.

Important: close bag tightly afterwards. Place strips in a suitable PCR tube rack.

If needed, gently tap the tubes to move the lyophilized pellets to the bottom of all tubes.

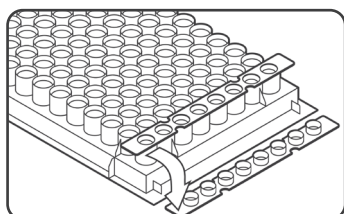

2. DECAP

Open strips carefully direct before filling and discard caps.

Important: do not leave open longer than necessary.

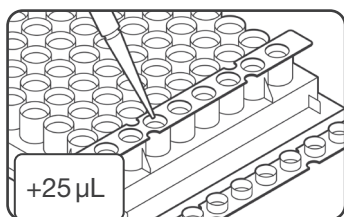

3. ADD SAMPLES AND CONTROLS

Pipette 25 µL of samples, negative control (colorless cap) or Control Template (purple cap) into respective wells.

If using less volume, add PCR-grade H₂O to reach 25 µL.

To reduce the risk of cross-contamination, prepare only one strip at a time.

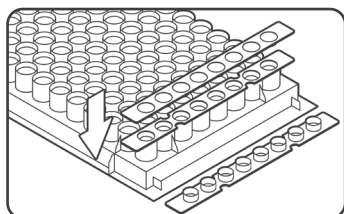

4. SEAL

Seal the tubes with the provided 8-cap strips tightly.

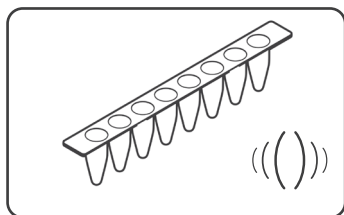

5. MIX

Resuspend pellet after sealing by mixing thoroughly.

Alternatively, resuspend pellet by pipetting up and down multiple times in step 3.

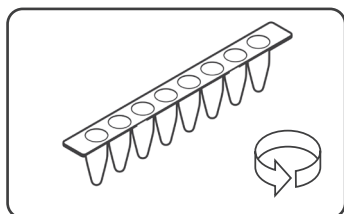

6. CENTRIFUGE

Briefly spin strips, e.g., 5 sec at 500 - 1,000 x g, in a suitable centrifuge.

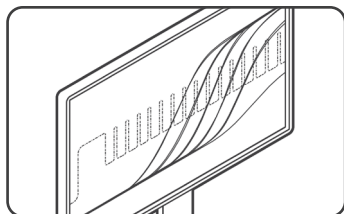

7. START REAL-TIME PCR RUN

Cycle samples as described in the program setup (2.4.2).

Place tubes in a vertical, balanced order into the cycler, e.g., two strips can be placed in the first and last column.

INSTRUCTIONS

2.4.2 Program Setup

Program your real-time PCR instrument before setting up the PCR reactions. Select the following channels:

- FAM (*Salmonella*), and VIC (Internal Control).

As an alternative to VIC, HEX can be used. For the PikoReal® 24, Yakima Yellow has to be selected.

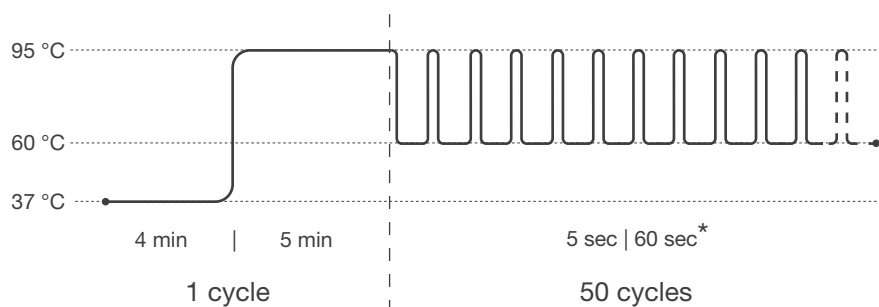

Pre-incubation: 1 cycle

Step 1: 37 °C for 4 min

Step 2: 95 °C for 5 min

Amplification: 50 cycles

Step 1 : 95 °C for 5 sec

Step 2*: 60 °C for 60 sec

* Fluorescence detection

For some real-time PCR instruments, the probe quencher as well as the usage of a passive reference dye has to be specified. This kit contains probes with a non-fluorescent (“dark”) quencher and no passive reference dye.

For users of the Agilent Mx3005P instrument: Click “Instrument” and “Filter Set Gain Settings” to open the Filter Set Gain Settings dialog box in which the gain settings may be viewed and modified. For FAM the Filter Set Gain Setting has to be modified to “x1”.

2.4.3 Data Interpretation

Verify results of positive (Control Template) and negative control (H₂O), before interpreting sample results. Always compare samples to positive and negative controls. Review data from each channel and interpret results as described in the table.

FAM	VIC	Result Interpretation
+	+ or -	Positive for <i>Salmonella</i>
-	+	Negative for <i>Salmonella</i>
-	-	Invalid

INSTRUCTIONS

2.5 Troubleshooting

Problem	Possible Cause	Recommendation
Squashed or crooked tubes, or open / dislodged tube lids after run, or the cycler does not open or close properly.	Wrong tube format.	Choose the correct tube format for your cycler. Tube profile and instrument compatibility chart is available online. If necessary, the samples can be transferred to appropriate PCR vessels after resuspension of the lyophilized PCR mix.
	Wrong placement of tubes.	Place tubes into the cycler in a vertical and balanced order, as described in the instructions for the PCR instrument.
No signal increase is observed, even with positive controls.	Incorrect detection channel has been chosen.	Set channel settings for respective dyes accordingly.
	Pipetting errors.	Check for correct reaction setup and repeat the PCR run. Always run a positive control along with your samples.
	No data acquisition programmed.	Check the cycle programs.
A sample shows no signals, including the internal control. Positive and negative control have proper signals.	Inhibitory effects of the sample material (e.g., caused by insufficient purification).	Use the recommended DNA extraction kit. Dilute samples or pipette a lower amount of sample DNA (e.g., 20 µL PCR-grade water and 5 µL sample instead of 25 µL sample).
Negative control samples are positive.	Carry-over contamination.	Exchange all critical solutions and reagents for DNA/RNA extraction. Repeat the complete experiment with fresh batches of all reagents. Always handle samples, kit components and consumables in accordance with commonly accepted practices to prevent carry-over contamination. Add positive controls after sample and negative control reaction vessels have been sealed.
Fluorescence intensity is too low.	Inappropriate storage of kit components.	Store lyophilized PCR mix at 2 to 8 °C, protected from light and moisture.
	Low initial amount of target DNA.	If possible, increase the amount of sample DNA. Depending on the chosen DNA isolation method, inhibitory effects may occur.

Troubleshooting continues on the next page

INSTRUCTIONS

Problem	Possible Cause	Recommendation
Strong decrease of fluorescence baseline.	Resuspension of lyophilized PCR mix not complete.	Always resuspend lyophilized PCR mix thoroughly. Use the recommended vortex centrifuge with the correct settings.
Fluorescence intensity varies or changes abruptly during the run.	Insufficient centrifugation of the PCR strips, e.g., resuspended PCR mix is still in the upper part of the vessel or bubbles trapped in the mix.	Always centrifuge PCR strips. Use the centrifuge models and settings recommended in this manual. Avoid the introduction of air bubbles during pipetting.
	Outer surface of the vessel or the seal is dirty (e.g., by direct skin contact).	Always wear gloves when handling the vessels and seal. Do not mark vessels on the outside of the tubes or directly on top of the reaction mix.
Pellets are difficult to dissolve.	The lyophilized PCR mix started to rehydrate.	Store the lyophilized PCR mix always in the aluminum bag with the silica gel pads. Make sure that the lids are tightly closed. Remove strips from the aluminum bag only shortly before PCR setup. Open strip shortly before filling.

2.6 Support

If you have questions or experience any problems with our products, please contact us:



www.hygiena.com/support

Our aim is to provide you with a solution as quickly and effectively as possible. We would also like you to contact us if you have any suggestions for improving the product or in case you would like to use our product for a different application. We highly value your feedback.

ADDITIONAL INFORMATION

3. ADDITIONAL INFORMATION

3.1 Testing Principle

The foodproof kit provides all necessary reagents and a control template for reliable interpretations of results. To ensure maximum reliability of the kit and to prevent misinterpretation of negative results due to inhibition of the amplification, an Internal Control (IC) is included. A hydrolysis probe was designed to bind specifically the IC, allowing detection in the respective channel, whereas the target DNA is detected in another channel. In case of a negative result due to inhibition of the amplification by the sample DNA of interest, the amplification of the IC is suppressed as well, whereas a negative result for the sample DNA of interest and amplification of the IC clearly indicates the absence of parameter in the sample. The real-time PCR kit minimizes contamination risk and contains all reagents (except for template DNA) needed for the detection of target DNA. Primers and probes provide specific detection of target DNA in food and environmental samples, including primary production stage samples. The described performance of the kit is guaranteed for use only on the real-time PCR instruments listed in 1.2 Applicability. For other instruments, please contact us.

Step-by-Step Procedure

1. Using the kit's sequence-specific primers in a polymerase chain reaction (PCR), the PCR instrument and the supplied reagents amplify fragments of specific sequences for target DNA.
2. The PCR instrument detects these amplified fragments in real time through fluorescence generated by cleavage of the hybridized probe due to the 5' nuclease activity of the Taq DNA polymerase. The probe is labeled at the 5' end with a reporter fluorophore and at the 3' end with a quencher.
3. During the annealing/elongation phase of each PCR cycle, the probe hybridizes to an internal sequence of the amplicon and is cleaved by the 5' nuclease activity of the Taq DNA polymerase. This cleavage of the probe separates the reporter dye from the quencher dye, increasing the reporter dye signal.
4. The PCR instrument measures the emitted fluorescence of the reporter dye.

Prevention of Carry-Over Contamination

The heat-labile Uracil-DNA N-Glycosylase (UNG) is suitable for preventing carry-over contamination between PCRs. This technique relies on the incorporation of deoxyuridine triphosphate (dUTP) during all amplification reactions, and the pretreatment of all successive PCR mixtures with the heat-labile UNG. The UNG cleaves DNA at any site where a deoxyuridine residue has been incorporated. The resulting abasic sites are hydrolyzed due to the high temperatures during the initial denaturation step, and can no longer serve as PCR templates. The heat-labile UNG is inactivated during the initial denaturation step. Native DNA (e.g., the isolated target genomic DNA) does not contain uracil and is therefore not degraded by this procedure. Since dTTP is replaced with dUTP and UNG is included in this kit, decontamination can be achieved with the provided reagents.

ADDITIONAL INFORMATION

3.2 Trademarks

foodproof[®], microproof[®], vetproof[®], ShortPrep[®], StarPrep[®], RoboPrep[®] and LyoKit[®] are trademarks of Hygiena Diagnostics GmbH.

Hygiena[®] is a registered trademark of Hygiena.

Other brand or product names are trademarks of their respective holders.

3.3 Reference Number

The reference number and original Hygiena Diagnostics GmbH article numbers:

R 602 27-1 (KIT23099), R 602 27-2 (KIT230101), R 602 27-3 (KIT230102), and R 602 27-1 L (KIT230100).

3.4 Change Index

Version 1, March 2014:

First version of the package insert.

Version 2, March 2017:

License Notice changed.

Introduction of vortex centrifuges into the PCR Setup Procedure.

Version 3, November 2019:

Introduction of R 602 27-3, new tube format for other real-time PCR instruments.

Introduction of MicroVal logo.

Version 4, February 2022:

Rebranding, new document layout, new order number.

Addition of the MicroVal method.

Revision A, September 2023:

Rebranding, new document layout, new order number.

Addition of the MicroVal method.

R 602 27 20 -> INS-KIT230099-100-101-102-REVA

Hygiena®

Camarillo, CA 93012
USA

diagnostics.support@hygiena.com

Manufactured by

Hygiena Diagnostics GmbH

Hermannswerder 17
14473 Potsdam
Germany

www.hygiena.com