



Anton Paar

Measure
what is measurable
and make measurable
that which is not.

Galileo Galilei (1564-1642)

Instruction Manual and Safety Information

L-Cor 8000/6000/4000

Standard Transmitter

Original Instructions

Disclaimer

This document may contain errors and omissions. If you discover any such errors or if you would like to see more information in this document, please contact us at our address below. Anton Paar assumes no liability for any errors or omissions in this document.

Changes, copyright, trademarks etc.

This document and its contents may be changed or amended by Anton Paar at any time without prior notice.

All rights reserved (including translation). This document, or any part of it, may not be reproduced, changed, copied, or distributed by means of electronic systems in any form (print, photocopy, microfilm or any other process) without prior written permission by Anton Paar GmbH.

Trademarks, registered trademarks, trade names, etc. may be used in this document without being marked as such. They are the property of their respective owner.

Further information

Address of the instrument producer: Anton Paar GmbH
Anton-Paar-Str. 20
A-8054 Graz / Austria – Europe
Tel: +43 (0) 316 257-0
Fax: +43 (0) 316 257-257
E-Mail: process@anton-paar.com
Web: www.anton-paar.com

Date: October 2024

Document number: XDPIB048EN-C

Instruction Manual and Safety Information

L-Cor 8000/6000/4000

Standard Transmitter

Original Instructions

Contents

L-Cor Series	4
1 Before You Begin	5
1.1 Confirming the Tag Information	5
1.2 Transportation Guidelines	5
1.3 Storage Guidelines	5
1.4 Precautions for Operating Conditions	5
1.5 Precautions for Installation Location.....	6
1.6 Precautions for Power-on	6
1.7 Returning Equipment.....	6
1.8 Safety Instructions	6
2 General and Features.....	8
2.1 General Description	8
2.2 Features.....	8
3 Specifications and Performance	9
3.1 Sensor Unit General Specifications.....	9
3.2 General Performance	17
3.3 Display	21
4 Pressure Losses.....	21
4.1 L-Cor 8000 Pressure Losses	21
4.2 L-Cor 6000 Pressure Losses	23
4.3 L-Cor 4000 Pressure Losses	24
5 Part Names and Outline Dimensions	25
5.1 L-Cor 8000.....	25
5.2 L-Cor 6000.....	39
5.3 L-Cor 4000.....	41
5.4 Separately Mounted Transmitter	43
6 Installation	44
6.1 General Installation Guidelines.....	44
6.2 Physical Orientation.....	44
6.3 Installation Location	48
6.4 Piping Installation Guidelines	49
6.5 Flange Installation Guidelines	51
6.6 Installing Proper Pipe Supports	53
6.7 Heat and Cold Retention Procedures.....	54
6.8 A Boss for Pressure Relief Device	57
6.9 Separately Mounted Transmitter Installation.....	57
6.10 How to Change Transmitter Orientation.....	58
6.11 How to Change Transmitter Display Orientation	59
7 Wiring Instructions.....	62
7.1 Wiring Connections	62
7.2 Power Supply Lines and Ground Terminal.....	63
7.3 Analog Output Wiring	63
7.4 Pulse Output Wiring.....	64
7.5 Status Output Wiring	64
7.6 Status Input Wiring	65
7.7 Communication Line Wiring (Option).....	65
7.8 Recommended Cables Condition.....	65
7.9 Terminal Identification of Separately Mounted Transmitter.....	67
7.10 Wiring Diagram	68
7.11 How to Change Cable Entry Orientation of Terminal Box	70
8 Operation	72
8.1 Flushing the Piping Assembly	72
8.2 Confirming the Sensor Unit for Correct Installation	72
8.3 Leak Check.....	72

8.4	Supplying the Power.....	72
8.5	Measurement Line Startup	72
8.6	Warm-up	72
8.7	Zeroing Procedure	72
8.8	Readying for Operation	72
9	Description of Incorporated Functions.....	73
9.1	Display	73
9.2	View Parameters and Description	78
9.3	Parameter Value Entry	92
9.4	Parameter Selection	93
9.5	Password Function	94
9.6	Self-diagnostic Capabilities	95
9.7	Simulated Signal Input/Output Capabilities	100
9.8	Zeroing Function.....	104
9.9	Analog Trim Function	107
9.10	Reset Function.....	108
9.11	View Variables Screen Setup	109
9.12	Pulse Output Function	110
9.13	Analog Output Function.....	113
9.14	Status Output.....	114
9.15	Status Input Function.....	115
9.16	High/Low Alarm Function	117
9.17	Gas Mixed Flow Alarm Function.....	119
9.18	Setup Unit List	121
10	Bell 202 command list	122
11	Maintenance	141
11.1	Error Messages	141
11.2	List of Status Messages	143
11.3	Replacement Parts	144
12	Regarding EHEDG Certification	145
13	Product Code Explanation	146
13.1	L-Cor 8000.....	146
13.2	L-Cor 6000.....	148
13.3	L-Cor 4000.....	149
14	KC Mark	150
15	Document Numbers	151

L-Cor Series

- **L-Cor 8000/8100/8200/8300 models:**

AU00A, AU001, AU003, AU006, AU010, AU015 AU025, AU040, AU050, AU080, AU100, AU150, AU15H

- **L-Cor 6000 models:**

AS010, AS015, AS025, AS040, AS050, ASR50

- **L-Cor 4000 models:**

AB006, AB010, AB015, AB025, AB040, AB050

- **Transmitter: PA0K (Standard)**

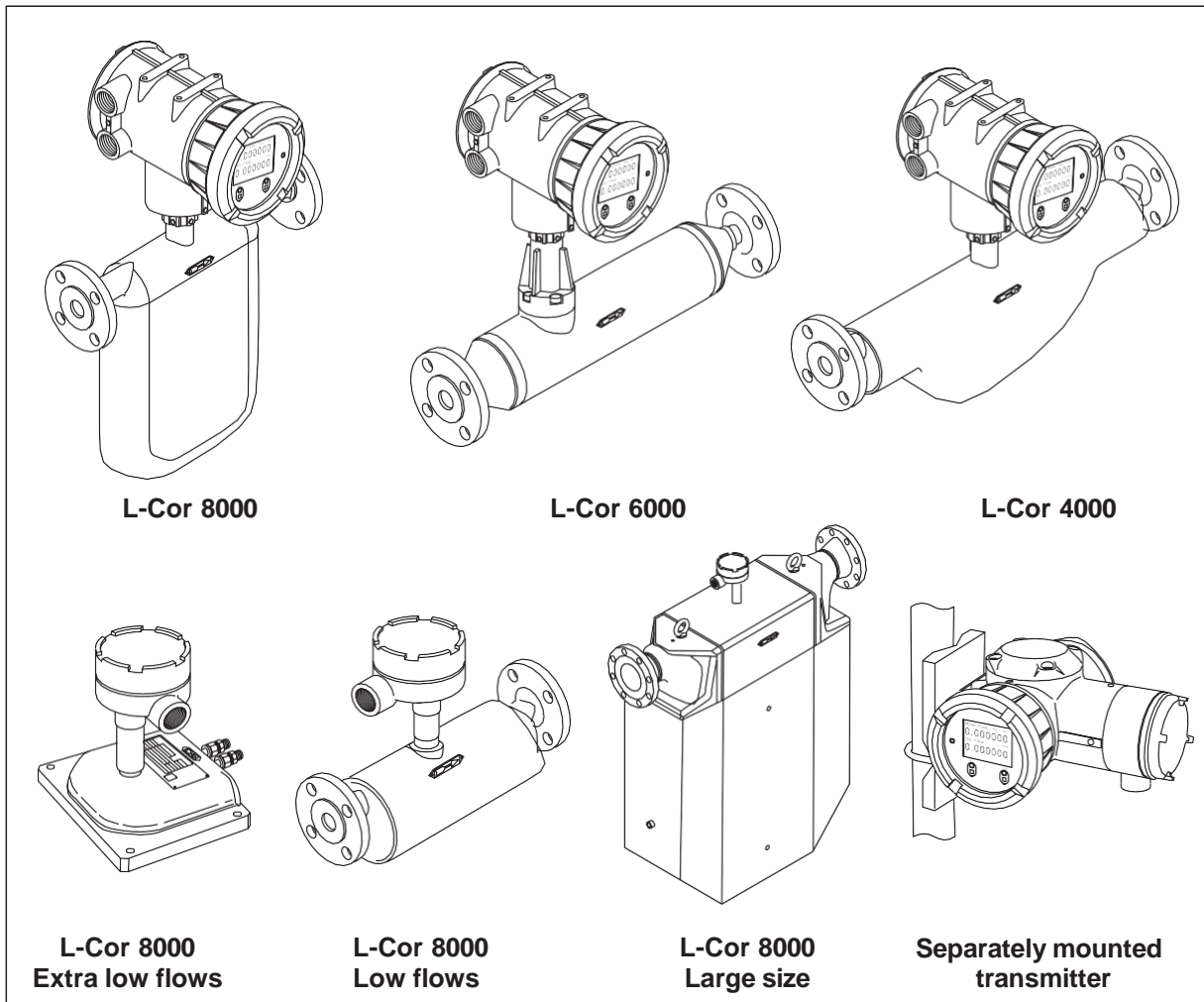

Every Anton Paar product is fabricated, tested, and inspected under stringent quality control before it leaves our factory.

To derive maximum benefit from our product, we recommend you to be well familiar with the information and instructions given in this manual before you place it in service and retain this manual at the field location for ready reference.

1 Before You Begin

When you received, the sensor and transmitter should be thoroughly inspected for any sign of damage in appearance by rough handling transit. Necessary handling precautions are explained in this section; read the instructions carefully.

For any inquiries, call the sales office from which you purchased the product, or contact the nearest Anton Paar representative in our customer service network.

1.1 Confirming the Tag Information

Read the documentation before using the instrument. Product code and major ratings appear on the nameplate attached on the side of transmitter. Make sure that the product you received complies with the specifications in your order.

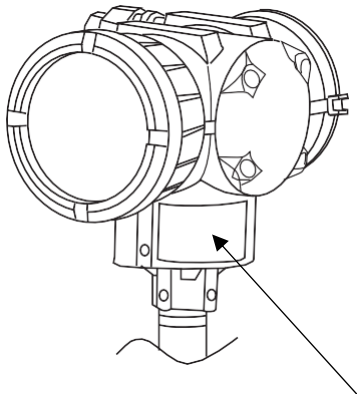

Information stated on the product tag

Item	Description
MODEL	Product model
SERIAL NO.	Serial No.
MAX. PRESS.	Max operating pressure
MAX. TEMP.	Max operating temperature
FLOW RANGE	Flow range
POWER	Power
TAG NO.	Instrument No. (only when specified)
BORE	Nominal flange size
DATE	Date of manufacture

1.2 Transportation Guidelines

(1) To prevent unexpected problems, transport the product to the installation site using the original manufacture's packing for shipment if circumstance permit.

(2) Use care to avoid impact shocks, rain and water during transportation.

1.3 Storage Guidelines

If this product is to be stored for long periods of time upon receipt before installation, unexpected problems can arise. So, when long-term storage is anticipated, it is suggested that the following precautions be taken:

(1) Store your product in the manufacture's original packing used for shipping if possible.

(2) Place of storage should conform to the following requirements:

- Free from rain and water.
- Free from vibration and impact shock.
- At room temperature with minimal temperature and humidity variation.

1.4 Precautions for Operating Conditions

In order to maintain metering accuracy and long service life, it is essential that the operating conditions, such as the flowrate, pressure, and temperature be held within the specified limits. These operating conditions are stated in Sections "3. SPECIFICATIONS and PERFORMANCE", "12. PRODUCT CODE EXPLANATION" of this manual. Do not fail to confirm these items before placing the meter in service.

- If the process fluid is corrosive, meter material must be checked in advance for compatibility.
- Cleanse the interior of flow tube thoroughly after use for measuring fluids that tend to deposit solids. A flow tube adhered with solid deposits can affect meter accuracy.
- If you want a change in operating conditions, consult Anton Paar.
- Non-uniform gas-liquid multiphase flow or non-uniform solid-liquid multiphase flow may not be measured properly. Consult Anton Paar for such applications.

- Blanking plug(s) included upon shipment is (are) only for protection of the screw thread during transportation and will not guarantee explosion-proof or IP performance. Do not install the device with this blanking plug connected regardless of explosion-proof or non-explosion-proof.

1.5 Precautions for Installation Location

CAUTION

- If there is a risk of process pressure exceeding flowmeter's permissible pressure, a pressure protection device must be installed on the process.
- Do not touch the surface of flowmeter directly. Depending on process conditions, the surface temperature of flowmeter may be high or low.
- To ensure accurate and consistent measurement, the Coriolis flowmeter should be installed in a location where pipeline oscillation do not exceed 0.3G.

1.6 Precautions for Power-on

Be sure to close the display lid and the terminal lid of the transmitter before turning on the power. The explosion-proof enclosure must be ensured (with the requirements stated in section 10.5 satisfied) before use.

To ensure the stable measuring condition, allow 20 minutes of warm-up period. "WARM UP 20" will be displayed for 20 minutes after powering-on. The number indicates remaining warm-up period (min.).

1.7 Returning Equipment

If the meter must be returned to Anton Paar for any reason, follow these steps to ensure the most efficient processing.

(1) Clean the unit and flush out the tubes without fail and pack the sensor unit carefully. Fully document the fluid. Inadequate information will delay handling of the meter.

(2) Enclose complete information about the material being returned including model and serial number, the reason for return, return address, and full documentation of the type of fluid.

(3) Pack the equipment carefully, using the original packing if possible.

(4) Return the complete flowmeter, including the separately electronics unit with all of the circuit boards and associated parts. Remove the conduit connections and all other parts not originally shipped with the meter. (Example: wiring connections)

WARNING

- Be sure to completely remove the deposit of residue on the inner walls of the sensor unit. Sensor unit cannot be disassembled for flushing the inner tubes. Malfunction diagnosis or service repair cannot be performed.
- Do not touch instrument or housing directly if the process temperature is high.
- Never loosen process connector nuts while instrument is still on process line, and never let explosive fluid burst into atmosphere.
- Do not touch process fluid or inside of instrument when removing instrument from hazardous process line.

1.8 Safety Instructions

- Read the documentation before using the instrument.
- Follow all hints and instructions contained in the documentation to ensure the correct use and safe functioning of the instrument.
- The documentation is a part of the product. Keep this document for the complete working life of the product and make sure it is easily accessible to all people involved with the product. If you receive any additions or revisions to the documentation from Anton Paar GmbH, these must be treated as part of the documentation.

Liability

- This document does not claim to address all safety issues associated with the use of the instrument and process fluids. It is your responsibility to establish health and safety practices and determine the applicability of regulatory limitations.
- Anton Paar GmbH only warrants the proper functioning of the instrument if no adjustments have been made to the mechanics, electronics, and firmware.

- Only use the instrument for the purpose described in the documentation. Anton Paar GmbH is not liable for damages caused by incorrect use of the instrument.

Installation and use

- Comply with local workplace safety regulations.
- Attention must be paid to all parts of the instrument.
- Sensors without an Ex-marking are not explosion-proof instruments and therefore must not be operated in areas with risk of explosion.
- Sensors with Ex-marking are intended for use in areas with risk of explosion. Special Safety Instructions must be read and followed for installation and use (see Chapter 1.3).
- The installation procedure should only be carried out by authorized personnel who are familiar with the installation instructions.
- Do not use any accessories or spare parts other than those supplied or approved by Anton Paar GmbH.
- Make sure all operators are trained to use the instrument safely and correctly before starting any applicable operations.
- In case of damage or malfunction, do not continue operating the instrument. Do not operate the instrument under conditions which could result in damage to goods and/or injuries and loss of life.
- Check the instrument for chemical resistance to the process fluids and cleaning fluids.
- Do not operate the instrument beyond its electrical, thermal and mechanical specifications.
- Do not step on the instrument.

Maintenance and service

- The results delivered by the instrument not only depend on the correct functioning of the instrument, but also on various other factors. We therefore recommend you have the results checked (e.g. plausibility tested) by skilled personnel before consequential actions are taken based on the results.
- Service and repair procedures may only be carried out by authorized personnel or by Anton Paar GmbH.

Disposal

- Concerning the disposal of the instrument, observe the legal requirements in your country. Confirming the Tag Information

Returns

- For repairs send the cleaned instrument to your Anton Paar representative. Only return the instrument together with the filled-out RMA (Return Material Authorization) and the form "Safety Declaration for Instrument Repairs". Please download the Safety Declaration form from our website www.anton-paar.com.
- Do not return instruments which are contaminated by radioactive materials, infectious agents or other harmful substances that cause health hazards.

WARNING

Description of risk.

- Warning indicates a hazardous situation which, if not avoided, could result in death or serious injury.

CAUTION

Description of risk.

- Caution indicates a hazardous situation which, if not avoided, could result in minor or moderate injury.

NOTE

Description of risk.

Notice indicates a situation which, if not avoided, could result in damage to property.

2 General and Features

2.1 General Description

The L-Cor series, consisting of a high performance model L-Cor 8000, a straight tube model L-Cor 6000, and a low-cost, general-purpose model L-Cor 4000, are Coriolis flowmeters capable of measuring mass flows at a high degree of accuracy. Equipped integrally or separately from the sensor unit is a highly sophisticated transmitter (self-diagnosis feature, large size display, and field reconfiguration capability using a touch panel).

2.2 Features

1. Further improved zero stability
2. Accurate density measurement
3. Increased output-signal availability: Pulse output (dual outputs), current output (dual outputs), and status output (single output)
4. Reconfiguration of transmitter parameters available with finger touch on the touch panel (also through communication)
5. Increased self-diagnostic capabilities: cable disconnection check, pipeline vibration check, and transmitter temperature monitoring, to name a few
6. Enhanced maintenance functions: error logging and factory default parameter reloading functions
7. 2 alarm indicators equipped
8. Compliant with various communication standards (Bell 202, Fieldbus, PROFIBUS PA, Modbus communication)
9. The measurement of bubble mixed fluid is possible by the adjustment of Gas Multiphase Flow Alarm (Slug Alarm) which is found in the Self-Diagnosis Function.

3 Specifications and Performance

3.1 Sensor Unit General Specifications

3.1.1 L-Cor 8000 sensor unit general specifications

● AU00A, AU001 and AU003

Item		Description		
Model		AU00A	AU001	AU003
Nominal flange size		1/4"		10mm, 3/8" (*1), DN15
Materials	Wetted parts	SUS316L		SUS316L, Alloy C-22 (*2)
	Housing	SUS304		
	O-rings	Fluorine rubber (Viton)		—
Process connection		R 1/4		ASME 150, 300, 600 RF / DIN 40 RF (*3), Tri-clamp ISO 2852 (*4), Threaded
Acceptable fluids		Liquid		
Density range		0 to 2.0 g/mL		
Viscosity range		Max 10000mPa·s (*5)		
Temperature range		-200 to +200°C		
Tube withstands (at 20°C)		15MPa		10MPa
Max operating pressure		15MPa at 20°C		Varies according to process connection
Sensor housing withstands (MPa) (*6)		—		7.2
Flow direction		Bidirectional		
Dust-tight, waterproof configuration		IP66 / 67		

NOTES:

- * 1: 1/2" for ASME flanges.
- * 2: When wetted parts are made from Alloy C, only threaded type connection is adopted as standard.
- * 3: DIN flanges are available only to meters of the wet part material, "SUS316L".
- * 4: For application to foods, this product does not comply with CE marking.
- * 5: If the viscosity is 10000mPa·s or more, contact Anton Paar.
- * 6: This pressure does not represent the rated test pressure of a pressure vessel, but 1/4 of the breakdown test pressure at Anton Paar (distorted enclosures do not constitute a failure of the test), or the data obtained from the FEM analysis, whichever is lower (or safer).
 - * Only separately mounted transmitter is applicable.

● AU006 to AU080

Item		Description						
Model		AU006	AU010	AU015	AU025	AU040	AU050	AU080
Nominal flange size		10mm, 3/8" (*1), DN15	15mm, 1/2", DN15		25mm, 1", DN25	40mm, 1 1/2", DN40	50mm, 2", DN50	80mm, 3", DN80
Materials	Wetted parts	SUS316L, Alloy C-22						
	Housing	SUS304						
Process connection		ASME 150, 300, 600 RF DIN 40 RF (*2), Tri-clamp ISO 2852 (*3), Threaded						
Acceptable fluids		Liquid						
Density range		0 to 2.0g/mL						
Viscosity range		Max 10000mPa·s (*4)						
Temperature range		Separately mounted: -200 to +200°C, Integrally mounted: -200 to +150°C (*5)						
Tube withstands (at 20°C)		9.4MPa (*6)						
Max operating pressure		Varies according to process connection						
Sensor housing withstands (MPa) (*7)		3.8	3.0	2.2	1.6	1.8	1.4	
Flow direction		Bidirectional						
Dust-tight, waterproof configuration		IP66 / 67						

NOTES:

- * 1: 1/2" for ASME flanges.
- * 2: DIN flanges are available only to meters of the wet part material, "SUS316L".
- * 3: For application to foods, this product does not comply with CE marking.
- * 4: If the viscosity is 10000mPa·s or more, contact Anton Paar.
- * 5: In case of PED specification, the minimum temperature lower limit is -196°C.
- * 6: Refer to section 3.1.5 for PED specification.
- * 7: This pressure does not represent the rated test pressure of a pressure vessel, but 1/4 of the breakdown test pressure at Anton Paar (distorted enclosures do not constitute a failure of the test), or the data obtained from the FEM analysis, whichever is lower (or safer).

● AU100 to AU15H

Item		Description		
Model		AU100	AU150	AU15H
Nominal flange size		100mm, 4", DN100	150mm, 6", DN150	
Materials	Wetted parts	SUS316L		
	Housing	SUS304		
Process connection		ASME 150, 300, 600 RF / DIN 40 RF		
Acceptable fluid		Liquid		
Density range		0.3 to 2.0g/mL		
Viscosity range		Max 10000mPa·s (*1)		
Temperature range		Separately mounted: -200 to +200°C, Integrally mounted: -200 to +150°C (*2)		
Tube withstands (at 20°C) (*3)		13.56MPa		10.6MPa
Max operating pressure		Varies according to process connection		
Flow direction		Bidirectional		
Dust-tight, waterproof configuration		IP66 / 67		

NOTES:

- * 1: If the viscosity is 10000mPa·s or more, contact Anton Paar.
- * 2: In case of PED specification, the minimum temperature lower limit is -196°C.
- * 3: Refer to section 3.1.5 for PED specification.

● L-Cor 8300 High Pressure Flowmeter (AU010 and AU015)

Item		Description	
Model		AU010 (high pressure service)	AU015 (high pressure service)
Materials	Wetted parts	Flow tube: Alloy C, Manifold: Equivalent to Alloy C (CX2MW)	
	Housing	SUS304	
Process connection		Threaded Rc 3/8	Threaded Rc 3/4
Acceptable fluids		Liquid	
Density range		0.3 to 2.0g/mL	
Viscosity range		Max 10000mPa·s (*1)	
Temperature range		Separately mounted: -200 to +200°C, Integrally mounted: -200 to +150°C	
Max operating pressure		36MPa at room temperature	43MPa at room temperature
Sensor housing withstands (*2)		3.0MPa	2.2MPa
Flow direction		Bidirectional	
Dust-tight, waterproof configuration		IP66 / 67	

NOTES:

- * 1: If the viscosity is 10000mPa·s or more, contact Anton Paar.
- * 2: This pressure does not represent the rated test pressure of a pressure vessel, but 1/4 of the breakdown test pressure at Anton Paar (distorted enclosures do not constitute a failure of the test), or the data obtained from the FEM analysis, whichever is lower (or safer).

● L-Cor 8200 Cryogenic Flowmeter (AU025 to AU15H)

Item		Description						
Model		AU025	AU040	AU050	AU080	AU100	AU150	AU15H
Nominal flange size		25mm, 1", DN25	40mm, 1- 1/2", DN40	50mm, 2", DN50	80mm, 3", DN80	100mm, 4", DN100	150mm, 6", DN150	
Materials	Wetted parts	SUS316L, Alloy C				SUS316L		
	Housing	SUS304						
Process connection (*1)		ASME 150, 300, 600 RF DIN 40 RF (*2), Tri-clamp ISO 2852 (*3)				ASME 150, 300, 600 RF DIN 40 RF (*2)		
Acceptable fluids		Liquid				Liquid		
Density range		0.3 to 2.0g/mL						
Viscosity range		Max 10000mPa·s						
Temperature range		-200 to +50°C (Separately mounted only)						
Tube withstands		9.4MPa (at 20°C)			13.56MPa (at 20°C)		10.6MPa (at 40°C)	
Max operating pressure		Varies according to process connection (*4)						
Sensor housing withstands (*5)		1.6MPa	1.8MPa	1.4MPa	—			
Flow direction		Bidirectional						
Dust-tight, waterproof configuration		IP66 / 67						

NOTES:

- * 1: When "SUS316L" is selected for the materials of wetted parts, the flange material is "SUS316". (AU025 to AU080)
- * 2: For the material of DIN flange, you cannot select "Alloy C".
- * 3: For application to foods, this product does not comply with CE marking.
- * 4: Refer to section 3.1.5 for PED specification.
- * 5: This pressure does not represent the rated test pressure of a pressure vessel, but 1/4 of the breakdown test pressure at Anton Paar (distorted enclosures do not constitute a failure of the test), or the data obtained from the FEM analysis, whichever is lower (or safer).
 - * Only separately mounted transmitter is applicable.

● L-Cor 8100 High Temperature Flowmeter (AU025 to AU080)

Item		Description			
Model		AU025 (high temperature service)	AU040 (high temperature service)	AU050 (high temperature service)	AU080 (high temperature service)
Nominal flange size		25mm, 1", DN25	40mm, 1 1/2", DN40	50mm, 2", DN50	80mm, 3", DN80
Materials	Wetted parts	SUS316L			SUS316L Alloy C-22
	Housing	SUS304			
Process connection		ASME 150, 300, 600 RF / DIN 40 RF			
Acceptable fluids		Liquid			
Density range		0.3 to 2.0g/mL			
Viscosity range		Max 10000mPa·s			
Temperature range (*1)		-40 to +350°C (Separately mounted only)			
Tube withstands (at 20°C)		9.4MPa			
Max operating pressure		Varies according to process connection (*2)			
Sensor housing withstands (*3)		1.6MPa	1.8MPa		1.4MPa
Flow direction		Bidirectional			
Dust-tight, waterproof configuration		IP66 / 67			

NOTES:

- * 1: Allowable ambient temperature permitted for the sensor unit is up to 50°C.
- * 2: Refer to section 3.1.5 for PED specification.
- * 3: This pressure does not represent the rated test pressure of a pressure vessel, but 1/4 of the breakdown test pressure at Anton Paar (distorted enclosures do not constitute a failure of the test), or the data obtained from the FEM analysis, whichever is lower (or safer).
- * Only separately mounted transmitter is applicable.

● L-Cor 8100 High Temperature Flowmeter (AU100, AU150)

Item		Description	
Model		AU100 (high temperature service)	AU150 (high temperature service)
Nominal flange size		100mm, 4", DN100	150mm, 6", DN150
Materials	Wetted parts	SUS316L	
	Housing	SUS304	
Process connection		ASME 150, 300, 600 RF / DIN 40 RF	
Acceptable fluids		Liquid	
Density range		0.3 to 2.0g/mL	
Viscosity range		Max 10000mPa·s	
Temperature range		-40 to +350°C (*1)	
Tube withstands (at 20°C)		13.5MPa	
Max operating pressure		Varies according to process connection (*2)	
Flow direction		Bidirectional	
Dust-tight, waterproof configuration		IP66 / 67	

NOTES:

- * 1: Max. ambient temperature of the sensor unit is 50°C.
- * 2: Refer to section 3.1.5 for PED specification.
- * Only separately-mounted transmitter is applicable.

3.1.2 L-Cor 6000 sensor unit general specifications

● Titanium tube type (AS010 to ASR50)

Item		Description					
Model		AS010	AS015	AS025	AS040	AS050	ASR50
Nominal flange size		10mm or 1/2"	15mm or 1/2"	25mm or 1"	40mm or 1-1/2"	50mm or 2"	80mm or 3"
Materials	Wetted parts	SB338 Grade-9+ TB480H					
	Housing	SUS304					
Process connection		ASME 150 / Tri-clamp ISO 2852 (*1)					
Acceptable fluid		Liquid					
Density range		0.5 to 1.0g/mL, 0.7 to 1.3g/mL, 1.0 to 1.5g/mL (*2)					
Measurable temperature range		-40 to +130°C (*3)					
Heatproof temperature		150°C max. (*4)					
Max operating pressure		Varies according to process connection					
Sensor housing withstands		2.8MPa					
Flow direction		Bidirectional					
Dust-tight, waterproof configuration		IP66 / 67					

NOTES:

- * 1: Loose flange is applied. Tri-clamp connections of models AS010 and AS015 comply with ISO2852.
- * 2: Density range varies with the fluid used.
- * 3: In case of non-explosion-proof models, the maximum measurement temperature of integrally mounted type is 130°C. However, the product must be used within the maximum ambient temperature of 45°C.
- * 4: CIP/SIP procedures must be performed within the heatproof temperature range.
 - * Temperature class for integral type is T4.
 - * If polished wetted parts are desired, contact Anton Paar.

3.1.3 L-Cor 4000 sensor unit general specifications

● General-purpose type (AB006 to AB050)

Item		Description					
Model		AB006	AB010	AB015	AB025	AB040	AB050
Nominal flange size		10mm or 1/2"	15mm or 1/2"	15mm or 1/2"	25mm or 1"	40mm or 1-1/2"	50mm or 2"
Materials	Wetted parts	SUS316L					
	Housing	SUS304					
Process connection		ASME 150, 300, 600 RF, Tri-clamp ISO 2852					
Acceptable fluid		Liquid					
Density range		0.3 to 2.0g/mL					
Measurable temperature range		-40 to +130°C (*1)					
Heatproof temperature		150°C max. (*2)					
Max operating pressure		Varies according to process connection					
Flow direction		Bidirectional					
Dust-tight, waterproof configuration		IP66 / 67					

NOTES:

- * 1: In case of non-explosion-proof model, up to 130°C is permitted. However, the product must be used within the maximum ambient temperature of 45°C.
- * 2: CIP/SIP procedures must be performed within the heatproof temperature range.

3.1.4 Transmitter general specifications

Item	Description	
Model	PA0K (Standard transmitter)	
Power source	20 to 30VDC	
Power consumption	15W max	
Ambient temperature	T6:	-40°C to +55°C for Separately mounted transmitter (*1)
	T4:	-40°C to +55°C (Tp**=-40°C to +80°C or -40°C to +70°C) for integral transmitter type.
		-20°C to +55°C (Tp**=-40°C to +80°C or -40°C to +70°C or -20°C to +80°C) for integral transmitter type. (*1)
**: Process temperature depends on sensor type. Refer to "Explosion-proof Specifications for Sensor unit".		
Transmission length (separately-located type)	L-Cor 8000	200 meters max (100 meters max for AU00A, AU001) (using dedicated 9 conductor cable) (*2)
	L-Cor 6000	Titanium tube type: 100 meters max (using dedicated 9 conductor cable) (*2)
	L-Cor 4000	50 meters max (using dedicated 9 conductor cable) (*2)
Explosion-proof Specifications/Applicable Guidelines	ATEX, IECEx, CSA, NEPSI (For details refer to Ex-proof manual)	
Applicable EU directive	EMC Directive: 2014/30/EU ATEX Directive :2014/34/EU LVD Directive: 2014/35/EU RoHS Directive: 2011/65/EU+ (EU) 2015/863	
Applicable EN standards	EMC: EN61326-1:2013 Class A LVD: EN61010-1:2010+A1:2019 RoHS: EN IEC 63000:2018 (For explosion-proof standards refer to Ex-proof manual)	
Dust-tight, waterproof configuration	IP66 / 67	
Transmitter construction	Integrally mounted or separately mounted	
Finish	Aluminum casing	
Display	LCD display (128x64dots) Backlight (white and orange) 2 infrared optical sensors and 2 LEDs (green and red)	
Weight	Integrally mounted type 3.6kg; Separately mounted type 5.0kg Separately mounted type for stainless casing 9.0kg	
Communication interface * Optional except for HART	Bell 202 (standard)	Bell 202 (*3)
	Modbus	RS-485 Modbus protocol, Baud rate: 9600bps, 19200bps, 38400bps (standard) RTU or ASCII, Response time: 25 to 50ms
	Fieldbus	AI blockx4, IT blockx2, with Link Master function
	PROFIBUS PA	AI blockx4, TOT blockx2
Damping (default)	L-Cor 8000 / Flowrate 0.8sec, density 4sec, temp. 2.5sec. L-Cor 6000 / Flowrate 1sec, density 4sec, temp. 2.5sec. (*3) L-Cor 4000 / Flowrate 1sec, density 4sec, temp. 2.5sec.	
Low flow cutoff (default)	L-Cor 8000/ 0.6% L-Cor 6000/ 1.5% L-Cor 4000/ 1.0%	
Pulse output (*4)	Open drain output (equivalent to open collector output) [Min. 10V to Max 30V, 50mADC, ON resistance 0.6Ωor less] or Voltage pulse (Low Level: 1.5V max High Level: 13V min. Output impedance: 2.2kΩ) Setting range: 0.1 to 0000Hz (Max output 11000Hz)	
Analog output (*4)	4 to 20mADC Max load 600Ω Select 2 outputs from instant flowrate (mass or volume), temp., concentration, and density.	
Status output (*4)	Open drain output (equivalent to open collector output) [Max 30V, 50mADC, ON resistance 0.6Ωor less] or Select one from error (*5), flow direction, and high/low alarm (default is error).	
Status input (*4)	Contact-closure input (Form "a" input) Short: 200Ω max Open: 100kΩ min. Select one from "remote zero adjust" total reset, 0% signal lock, and function OFF (default is function OFF).	

NOTES:

- * 1: Below -20°C, the display loses its visibility due to weakened contrast. Both the display and infrared sensor may exhibit slow responses below -20°C.
- * 2: If signal transmission length exceeds the max transmission length, consult Anton Paar.
 - * The operating temperature range of the dedicated cable (PVC: model code CBP2) is -15 to +80°C.
 - * Use dedicated cable (PTFE: model code CBT2) instead in an environment that exceeds the above temperature range.
- * 3: Of the two analog output systems, only analog output 1 is available for Bell 202 communication.
- * 4: When Fieldbus, PROFIBUS PA is selected as the communication interface, all input and output signals will be turned off.
- * 5: Of error outputs, "zero adjust is in progress" status output can also be set up.
 - * Denoising parts are embedded in the lines between power source, output, communication, and the chassis.
Lower the applied voltage to the following levels in order to conduct insulation test or withstand voltage test on these lines.
AC : 200V, DC : 250V

Specific condition of uses:

- Repair of the flameproof joints is not allowed.
- The property class of special fasteners is A2-50.
- The equipment shall be used in the positions as specified in the instruction manual.
- The capacitance of the label is maximum 1 nF, exceeds the limit of IEC 60079-0. The user shall determine suitability in the specific application.
- Electrostatic charges on the non-metallic parts and coated parts of the equipment shall be avoided.

● **Flange ratings and allowable pressure (MPa)**

Meter size/nominal diameter: AU003 to 15H Unit: MPa

	ASME 150	ASME 300	ASME 600 (*1)	DIN PN40
RT	1.9	4.96	9.93	4.00
100	1.62	4.22	8.44	4.00
120	1.59	4.21	8.40	3.85
150	1.48	3.85	7.70	3.68
200	1.37	3.57	7.13	3.37
220	1.26	3.63	6.98	3.29
300	1.00	3.16	6.14	2.97
350	0.84	3.03	6.07	2.85

* 1: Meter size / Nominal Diameter 003 (Connections SUS316L), 006 to 080, have sensor tube pressure resistance.

Meter size/nominal diameter: AS010 to R50 Unit: MPa

	ASME 150
RT	1.9
130	1.3

Meter size/nominal diameter: AB006 to 050 Unit: MPa

	ASME 150	ASME 300	ASME 600 (*1)
RT	1.9	4.96	7.90
125	1.3	3.47	—

* 1: Sensor will be sensor tube pressure resistance.

Pressure Equipment Directive 2014/68/EU (PED)

This product complies with the following Pressure Equipment Directive 2014/68/EU (PED).

Quality system: Full quality assurance (Module H) Notified body: 0035

Equipment category: Pressure accessory

Fluid group: Liquid (Group 1 or Group 2)

Category: Tables 3 and 8 in Appendix II concerning PED (*1)

The following PED nameplates are affixed to products (sensors) that fall under Category II.

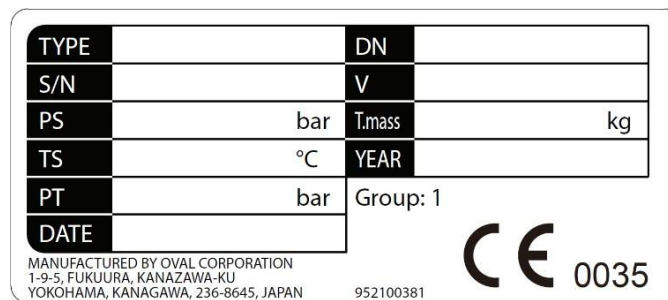

PED Label

Former product code: AU series

Applicable category	Product code		Applicable category	Product code	
Sound Engineering Practice (*2)	AU00A	-xxxxx-2xB-1xxxx-x	Category II (*3)	AU040	-LxSA6-2xB-1xxxx-0
	AU001	-xxxxx-2xB-1xxxx-x		AU050	-LxSA3-2xB-1xxxx-0
	AU003	-xxxxx-2xB-1xxxx-x		AU080	-LxSA6-2xB-1xxxx-0
	AU006	-xxxxx-2xB-1xxxx-x			-LxSA6-2xB-1xxxx-0
	AU010	-xxxxx-2xB-1xxxx-x			-xxSB3-2xB-1xxxx-0
	AU015	-xxxxx-2xB-1xxxx-x			-xxSB6-2xB-1xxxx-0
	AU025	-xxxxx-2xB-1xxxx-x		AU100	-xxSA3-2xB-1xxxx-0
	AU040	-xxxA1-2xB-1xxxx-x			-xxSA6-2xB-1xxxx-0
		-xxxA3-2xB-1xxxx-x			-xxSDB-2xB-1xxxx-0
		-xxxD1-2xB-1xxxx-x			-xxSD3-2xB-1xxxx-0
		-xxxDB-2xB-1xxxx-x			-xxSD4-2xB-1xxxx-0
		-xxxD3-2xB-1xxxx-x			
		-xxxD4-2xB-1xxxx-x			
	AU050	-xxxA1-2xB-1xxxx-x			
		-xxxD1-2xB-1xxxx-x			
		-xxxDB-2xB-1xxxx-x			
		-xxxD3-2xB-1xxxx-x			
		-xxxD4-2xB-1xxxx-x			
	AU080	-xxxA1-2xB-1xxxx-x			
		-xxxD1-2xB-1xxxx-x			
		-xxxDB-2xB-1xxxx-x			
		-xxxD3-2xB-1xxxx-x			
		-xxxB1-2xB-1xxxx-x			
		-xxxE1-2xB-1xxxx-x			
	AU100	-xxxA1-2xB-1xxxx-x			
		-xxxD1-2xB-1xxxx-x			
	AU150	-xxxD1-2xB-1xxxx-x		AU150	-xxSvv-2xB-1xxxx-0
				AU15H	-xxSvv-2xB-1xxxx-0

X: All product codes are supported.

V: Shows ASME and DIN flange only. Other flange ratings are not allowed.

- * 1: Maximum Allowable Pressure (SB338 Grade-9+TB480H) : PS of each sensor, Nominal Size (DN) and Volume (V), has been categorize using the Tables 3 and 8 of Annex II on PED.
- * 2: Applicable to Article 4, Paragraph 3 of PED.
- * 3: Only Stainless Steel are possible to be used as connection material, other materials are not possible.

Former product code: AS series

Applicable category	Product code	
Sound Engineering Practice (*2)	AS010	-x1Txx-2x□-xxxxx-x
	AS015	-x1Txx-2x□-xxxxx-x
	AS025	-x1Txx-2x□-xxxxx-x
	AS040	-x1Txx-2x□-xxxxx-x
	AS050	-x1Txx-2x□-xxxxx-x
	ASR50	-x1Txx-2x□-xxxxx-x

X: All product codes are supported.

□: Shows codes other than B.

- * 1: Maximum Allowable Pressure (SB338 Grade-9+TB480H): PS of each sensor, Nominal Size (DN) and Volume (V), has been categorize using the Tables 3 and 8 of Annex II on PED.
- * 2: Applicable to Article 4, Paragraph 3 of PED.

Former product code: AB series

Applicable category	Product code		Applicable category	Product code	
Sound Engineering Practice (*2)	AB006	-L1Sxx-2x□-1xxxx-x	Category II	AB040	-L1SA6-2xB-1xxxx-x
	AB010	-L1Sxx-2x□-1xxxx-x		AB050	-L1SA3-2xB-1xxxx-x
	AB015	-L1Sxx-2x□-1xxxx-x		AB050	-L1SA6-2xB-1xxxx-x
	AB025	-L1Sxx-2x□-1xxxx-x			
	AB040	-L1SA1-2x□-1xxxx-x			
		-L1SA3-2x□-1xxxx-x			
	AB050	-L1SA1-2x□-1xxxx-x			

X: All product codes are supported.

□: Shows codes other than B.

- * 1: Maximum Allowable Pressure (F316): PS of each sensor, Nominal Size (DN) and Volume (V), has been categorize using the Tables 3 and 8 of Annex II on PED.
- * 2: Applicable to Article 4, Paragraph 3 of PED.

3.2 General Performance

3.2.1 L-Cor 8000 General Performance

● Flowrate

Type	Model	Inch	Guaranteed min. rate (kg/h)	Min. setting rate (kg/h)	Max. service rate (kg/h)	Max. allowable rate (kg/h)	Zero stability (kg/h)
L-Cor 8000	AU00A	1/4"	0.024 (0.4g/min)	0.12 (2g/min)	2.4 (40g/min)	3.6 (60g/min)	0.00024
	AU001		0.09 (1.5g/min)	0.45 (7.5g/min)	9 (150g/min)	13.5 (225g/min)	0.0009
	AU003	3/8"	0.72 (0.9 *1)	3.6	72	144 (180 *1)	0.0018
	AU006	3/8"	3.6	18	360	720	0.018
	AU010	1/2"	12	60	1200	2400	0.06
	AU015	1/2"	36	180	3600	7200	0.18
L-Cor 8000 and L-Cor 8200	AU025	1"	108	540	10800	21600	0.54
	AU040	1 · 1/2"	390	1950	39000	78000	1.95
	AU050	2"					
	AU080	3"	1200 (1.2t/h)	6000 (6t/h)	120000 (120t/h)	240000 (240t/h)	6
	AU100	4"	3420 (3.42t/h)	17100 (17.1t/h)	342000 (342t/h)	684000 (684t/h)	17.1
	AU150	6"					
AU15H	6"	7000 (7t/h)	35000 (35t/h)	700000 (700t/h)	1400000 (1400t/h)	35	
L-Cor 8300	AU010	Rc3/8	24	120	840	1680	0.21
	AU015	Rc3/4	78	390	2550	5100	0.636
L-Cor 8100	AU025	1"	108	540	10800	21600	1.08
	AU040	1 · 1/2"	390	1950	39000	78000	3.9
	AU050	2"					
	AU080	3"	1200 (1.2t/h)	6000 (6t/h)	120000 (120t/h)	240000 (240t/h)	12
	AU100	4"	3420 (3.42t/h)	17100 (17.1t/h)	342000 (342t/h)	684000 (684t/h)	34.2
	AU150	6"					

NOTES:

* 1: When maximum allowable range 180 kg/h is adopted, the minimum flow rate is 0.9 kg/h.

● **Density (Liquids)**

Type	Model	Inch	Density (Liquids)	
			Metering range	Analog output accuracy
L-Cor 8000	AU00A	1/4"	0.3 to 2g/mL	Accuracy ±0.1% of full scale
	AU001			
	AU003	3/8"		
	AU006	3/8"		
	AU010	1/2"		
	AU015	1/2"		
L-Cor 8000 and L-Cor 8200	AU025	1"		
	AU040	1 · 1/2"		
	AU050	2"		
	AU080	3"		
	AU100	4"		
	AU150	6"		
	AU15H	6"		

Type	Model	Inch	Density (Liquids)	
			Metering range	Analog output accuracy
L-Cor 8300	AU010	Rc3/8	0.3 to 2g/mL	Accuracy ±0.1% of full scale
	AU015	Rc3/4		
L-Cor 8100	AU025	1"		
	AU040	1 · 1/2"		
	AU050	2"		
	AU080	3"		
	AU100	4"		
	AU150	6"		

NOTES:

The accuracy is based on the calibration accuracy at factory. When measuring a cryogenic fluid such as LNG, please contact Anton Paar.

● **Standard and L-Cor 8200 Cryogenic Flowmeter (AU100 to AU15H)**

Item		Description		
Model		AU100	AU150	AU15H
Flowrate	Guar. min. meas. rate (kg/h)	3420		7000
	Min. setting rate (kg/h)	17100		35000
	Max allowable rate (kg/h)	684000		1400000
	Max service rate (kg/h)	342000		700000
	Zero stability (kg/h)	17.1		35
Density (liquid)	Measuring rate	0.3 to 2.0g/mL		
	Factory calibration. acc. (opt)	±0.0005g/mL		
Analog output accuracy		0.1% of full scale for respective accuracy		

 **CAUTION:** For applications of volume flow measurement subject to taxation or in transactions, consult Anton Paar.

● L-Cor 8300 High Pressure Flowmeter (AU010 and AU015)

Item		Description	
Model		AU010 (L-Cor 8300)	AU015 (L-Cor 8300)
Flowrate	Guar. min. meas. rate (kg/h)	24	78
	Min. setting rate (kg/h)	120	390
	Max service rate (kg/h)	840	2550
	Max allowable rate (kg/h)	1680	5100
	Zero stability (kg/h)	0.21	0.636
Density (liquid)	Measuring rate	0.3 to 2.0g/mL	
Analog output accuracy		0.1% of full scale for respective accuracy	

NOTE: The general performance is based on factory calibration accuracy.

⚠ CAUTION: For applications of volume flow measurement subject to taxation or in transactions, consult Anton Paar.

● L-Cor 8100 High Temperature Flowmeter (AU025 to AU080)

Item		Description			
Model		AU025 (L-Cor 8100)	AU040 (L-Cor 8100)	AU050 (L-Cor 8100)	AU080 (L-Cor 8100)
Flowrate (liquid)	Guar. min. meas. rate (kg/h)	108	390		1200
	Min. setting rate (kg/h)	540	1950		6000
	Max allowable rate (kg/h)	21600	78000		240000
	Max service rate (kg/h)	10800	39000		120000
	Zero stability (kg/h)	1.08	3.9		12
Density (liquid)	Measuring rate	0.3 to 2.0g/mL			
Analog output accuracy		0.1% of full scale for respective accuracy			

NOTE: The general performance is based on factory calibration accuracy.

● L-Cor 8100 High Temperature Flowmeter (AU100, AU150)

Item		Description	
Model		AU100 (L-Cor 8100)	AU150 (L-Cor 8100)
Flowrate (liquid)	Guar. min. meas. rate (kg/h)	3420	
	Min. setting rate (kg/h)	17100	
	Max service rate (kg/h)	342000	
	Max allowable rate (kg/h)	684000	
	Zero stability (kg/h)	34.2	
Density (liquid)	Measuring rate	0.3 to 2.0g/mL	
Analog output accuracy		0.1% of full scale for respective accuracy	

NOTE: The general performance is based on factory calibration accuracy.

3.2.2 L-Cor 6000 General Performance

● Titanium tube type (AS010 to ASR50)

Item		Description					
Model		AS010	AS015	AS025	AS040	AS050	ASR50
Flowrate	Guar. min. meas. rate (kg/h)	36	120	360	900	1800	
	Min. setting rate (kg/h)	72	240	720	1800	3600	
	Max service rate (kg/h)	1220	4080	12200	30600	61200	
	Max allowable rate (kg/h)	1830	6120	18300	45900	91800	
	Zero stability (kg/h)	0.12	0.41	1.22	3.06	6.12	
Density (liquid)	Measuring rate	0.5 to 1.0g/mL, 0.7 to 1.3g/mL, 1.0 to 1.5g/mL (*1)					
Analog output accuracy		0.1% of full scale for respective accuracy					

NOTES:

- * 1 : Density range varies with the fluid used.
- * When measuring the density at fluid temperature 40°C or higher, heat retention measures must be taken.
- * The general performance is based on factory calibration accuracy.

3.2.3 L-Cor 4000 General Performance

● General-purpose type (AB006 to AB050)

Item		Description					
Model		AB006	AB010	AB015	AB025	AB040	AB050
Flowrate	Guar. min. meas. rate (kg/h)	24	76.8	192	576	1920	
	Min. setting rate (kg/h)	60	192	480	1440	4800	
	Max service rate (kg/h)	600	1920	4800	14400	48000	
	Max allowable rate (kg/h)	1200	3840	9600	28800	96000	
	Zero stability (kg/h)	0.09	0.288	0.72	2.16	7.2	
Density	Measuring rate	0.3 to 2.0g/mL					
Analog output accuracy		0.1% of full scale for respective accuracy					

NOTES:

- * The general performance is based on factory calibration accuracy

3.3 Display

Display modes

- ① Mass instant flowrate
- ② Volume instant flowrate
- ③ Density
- ④ Temperature
- ⑤ Pulse count 1 (mass or volume)
- ⑥ Pulse count 2 (mass or volume)
- ⑦ Total 1 (mass or volume)
- ⑧ Total 2 (mass or volume)
- ⑨ Analog 1 (% instant)
- ⑩ Analog 2 (% instant)
- ⑪ Status information
- ⑫ Mode select (parameter setup)
- ⑬ Concentration (Option)

Communication interfaces Fieldbus, PROFIBUS PA display different contents.
For further information, refer to the instruction manuals of respective communication interfaces.

A touch of a finger on the touch panel through the front glass (infrared optical sensor) selects the mode.

NOTE: If the infrared sensors do not respond sufficiently, use L-Cor software to adjust the sensitivity. In case you do not have L-Cor software, use a reflecting subject, such as a sheet of paper, to operate the switches.

LCD backlight comes in two colors: white and orange. Color changes according to the status of flowmeter. Backlight usually comes off automatically if the optical sensor does not respond for a certain period of time. Backlight duration is selectable.

Fig. 3.1

4 Pressure Losses

4.1 L-Cor 8000 Pressure Losses

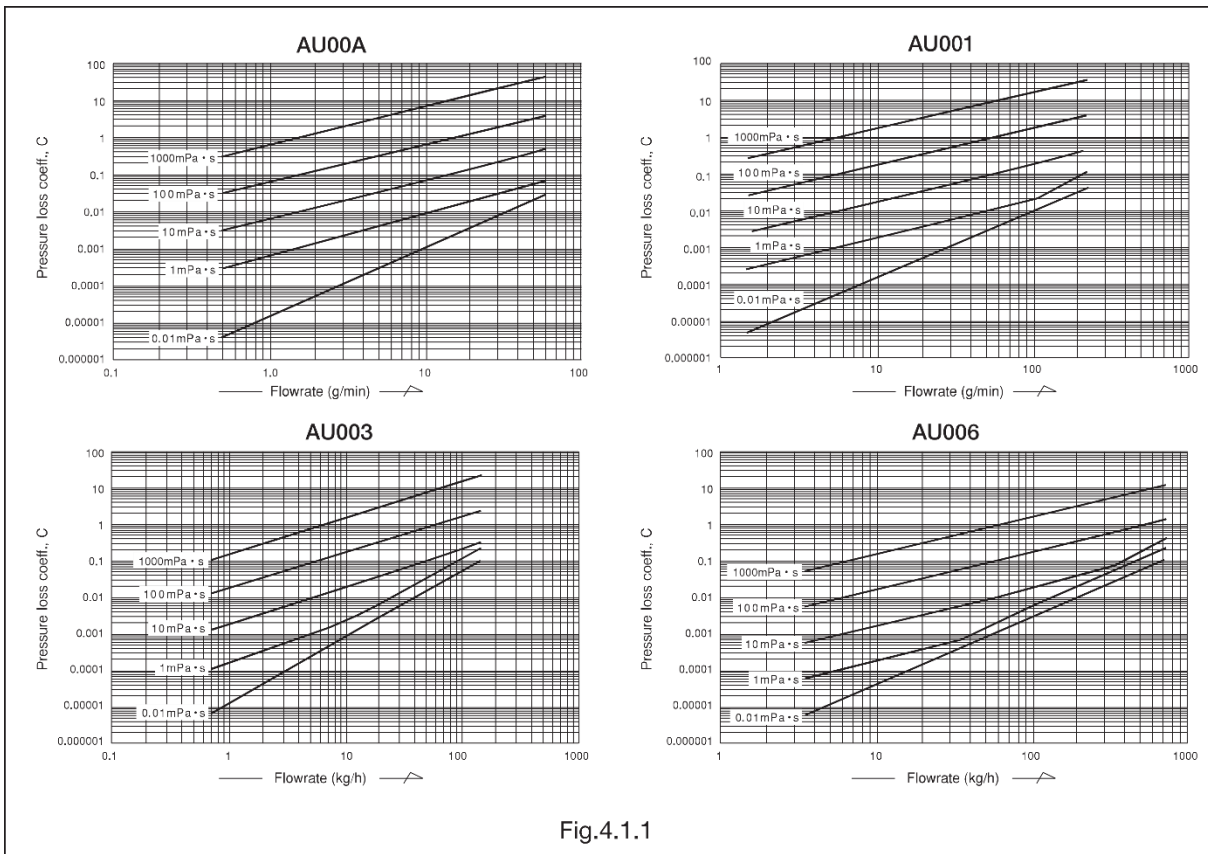

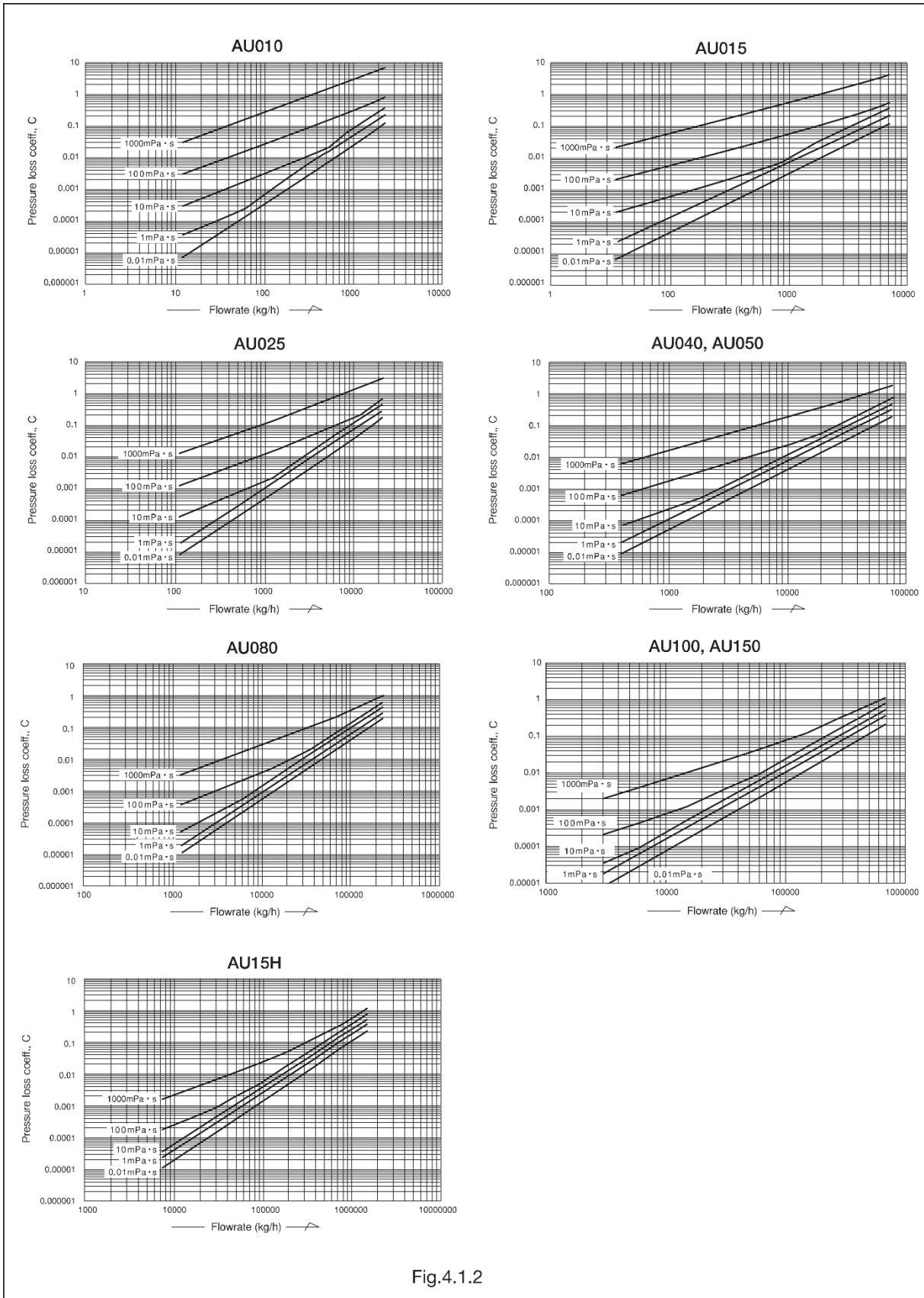

Fig.4.1.2

4.2 L-Cor 6000 Pressure Losses

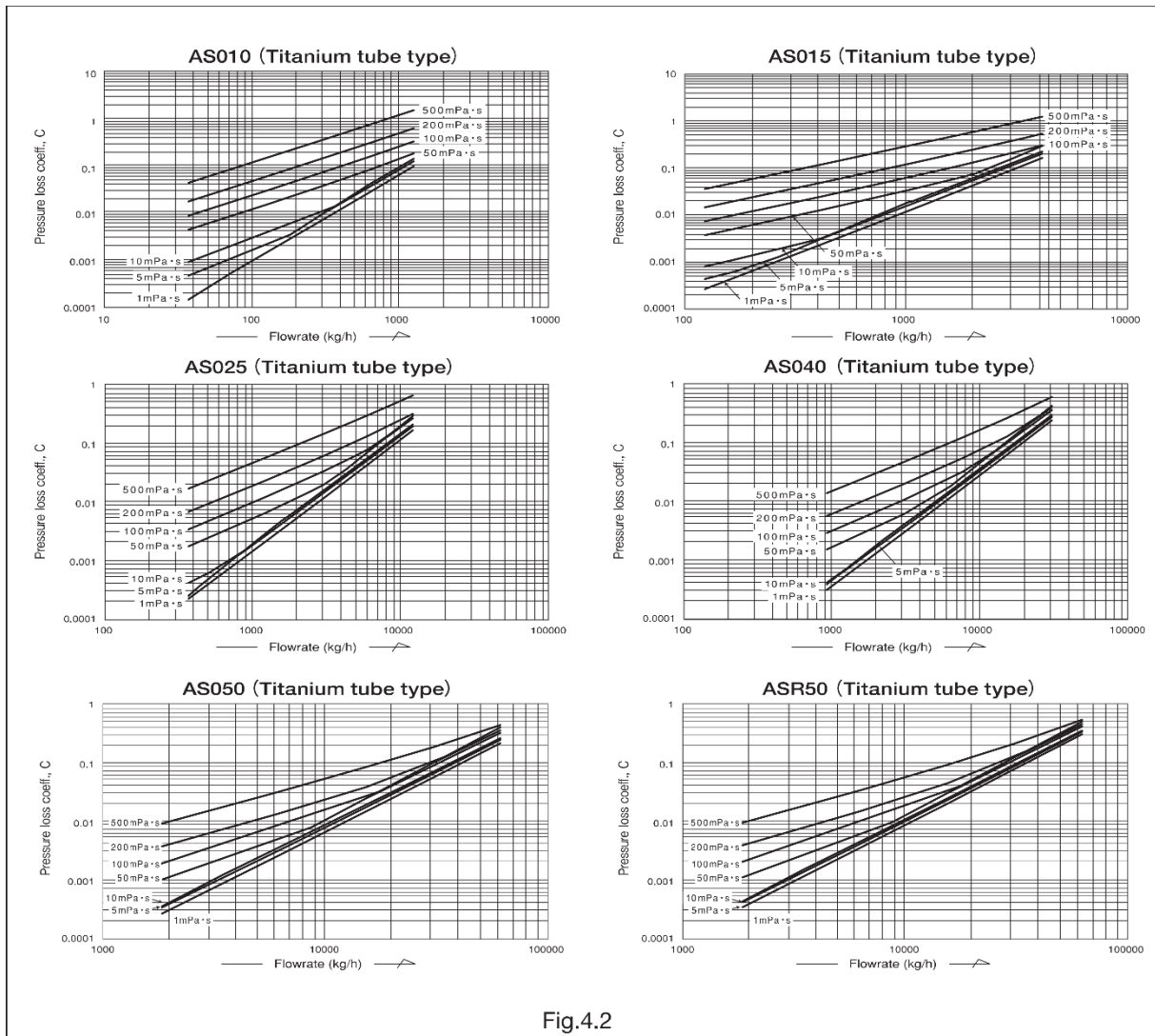

Fig.4.2

4.3 L-Cor 4000 Pressure Losses

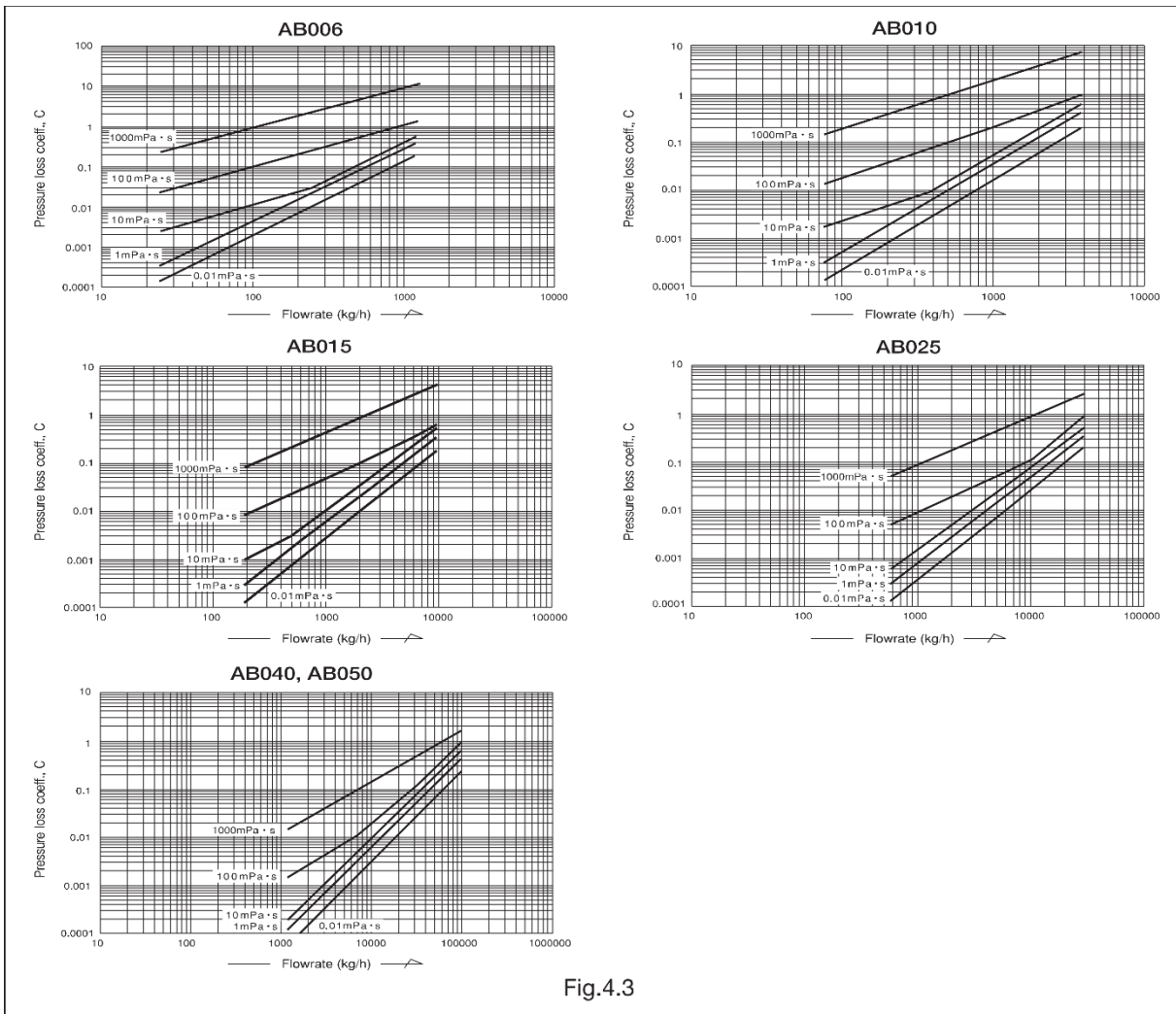

Fig.4.3

How to determine pressure loss:

(1) Seeing the graph of the type of flowmeter to be used, find the pressure loss coefficient C from the flowrate (g/min. or kg/h) and viscosity (mPa·s). Dividing this value C by specific gravity d (1 for water) gives the pressure loss, or

$$\Delta P = \frac{C}{D} \text{ (MPa)}$$

Pressure loss is calculated with Newtonian fluid. For Non-Newtonian fluid, please consult Anton Paar.

(2) For high-viscosity liquids not shown in the graphs, calculate the pressure loss by the following equation:

$$\Delta P_2 = C \times \frac{\mu_2}{\mu_1} \times \frac{1}{d}$$

where:

- ΔP_2 : Pressure loss of high-viscosity liquid (MPa)
- μ_1 : Maximum viscosity shown in the graph (mPa·s)
- μ_2 : Viscosity of high-viscosity liquid (mPa·s)
- d: Specific gravity of high-viscosity liquid (1 for water)
- C: Pressure loss coefficient found from the maximum viscosity curve at a given flowrate (g/min. or kg/h)

5.1.2 AU006 to AU080 (integrally mounted models)

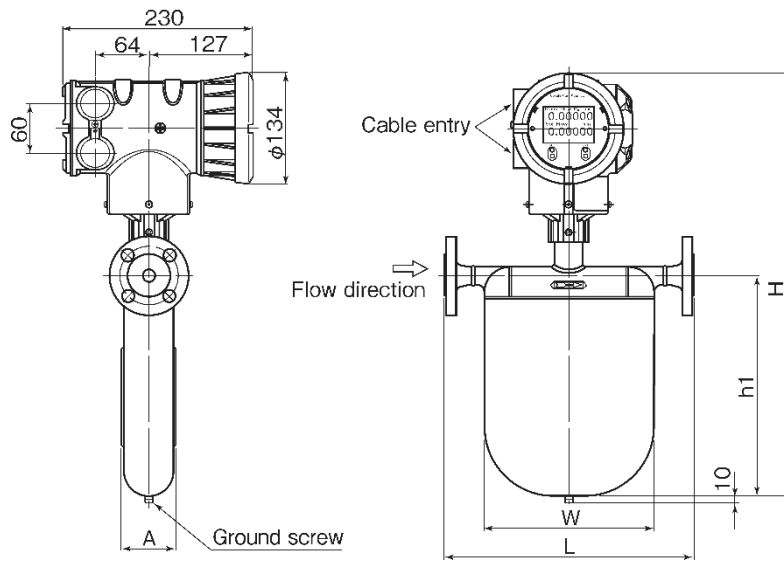

Fig. 5.3 Outline Dimensions of Integrally Mounted Model (1/3)

Stainless steel models (316L)

Dimensions in millimeters

Model	Flange		L	H	h1	A	W	App. Weight (kg)
	Nom. size	Flange rating						
AU006	3/8"	ASME 150	267	424	180	53	148	7
		ASME 300	276					
		ASME 600	289					
	DN15	PN 40	247					
AU010	1/2"	ASME 150	282	462	218	53	163	7.8
		ASME 300	291					
		ASME 600	303					
	DN15	PN 40	261					
AU015	1/2"	ASME 150	325	512	268	65	205	8.8
		ASME 300	334					
		ASME 600	347					
	DN15	PN 40	305					
AU025	1"	ASME 150	411	580	329	83	262	13.3
		ASME 300	424					
		ASME 600	437					
	DN25	PN 40	380					

Alloy C-22 models

Model	Flange		L	H	h1	A	W	App. Weight (kg)
	Nom. size	Flange rating						
AU006	3/8"	ASME 150	286	424	180	53	148	7
		ASME 300						
		ASME 600						
AU010	1/2"	ASME 150	300	462	218	53	163	7.8
		ASME 300						
		ASME 600						
AU015	1/2"	ASME 150	344	512	268	65	205	8.8
		ASME 300						
		ASME 600						
AU025	1"	ASME 150	444	580	329	83	262	13.3
		ASME 300						
		ASME 600						

Threaded type

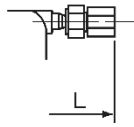

Fig. 5.4 Outline Dimensions of Integrally Mounted Model (2/3)

Model	Screw connection	L	App. Weight (kg)
AU006	Rc3/8	296	5.7
AU010	Rc3/8	312	6.3
AU015	Rc3/4	382	7.1

Stainless steel models (316L)

Dimensions in millimeters

Model	Flange		L	H	h1	A	W	App. Weight (kg)
	Nom. size	Flange rating						
AU040	1 · 1/2"	ASME 150	547	710	452	121	385	23
		ASME 300	560					
		ASME 600	575					
	DN40	PN 40	513					
AU050	2"	ASME 150	550	710	452	121	385	23
		ASME 300	563					
		ASME 600	582					
	DN50	PN 40	519					
AU080	3"	ASME 150	698	880	602	174	510	57
		ASME 300	717					
		ASME 600	737					
	DN80	PN 40	675					

Alloy C-22 models

Model	Flange		L	H	h1	A	W	App. Weight (kg)
	Nom. size	Flange rating						
AU040	1 · 1/2"	ASME 150	587	710	452	121	385	23
		ASME 300						
		ASME 600						
AU050	2"	ASME 150	587	710	452	121	385	23
		ASME 300						
		ASME 600						
AU080	3"	ASME 150	756	880	602	174	510	57
		ASME 300						
		ASME 600						

5.1.3 AU100 to AU15H (integrally mounted models)

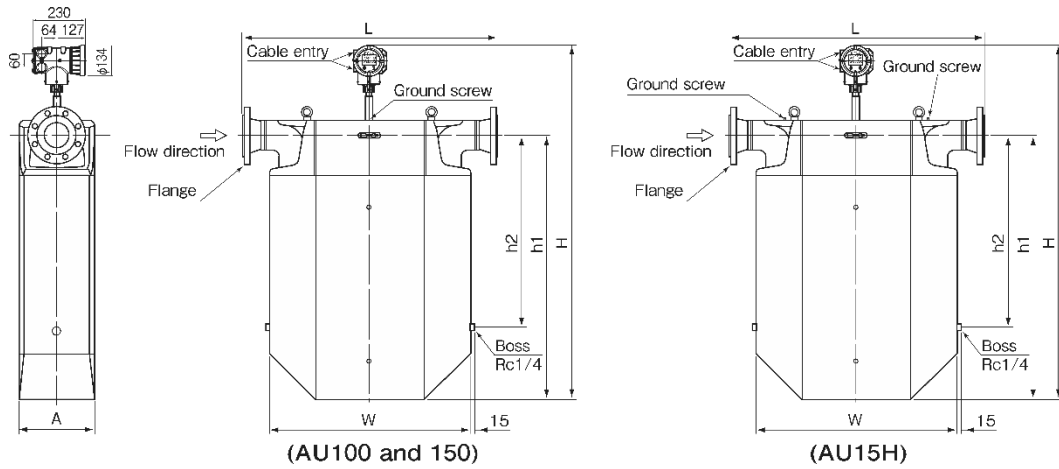

Fig. 5.5 Outline Dimensions of Integrally Mounted Model (3/3)

Dimensions in millimeters									
Model	Flange		L	H	h1	h2	A	W	App. Weight (kg)
	Nom. size	Flange rating							
AU100	4"	ASME 150	1018	1403	1015	660	300	810	231
		ASME 300	1036						
		ASME 600	1082						
	DN100	PN 40	994						
AU150	6"	ASME 150	1318	1403	1015	660	300	810	246
		ASME 300	1338						
		ASME 600	1388						
	DN150	PN 40	1290						
AU15H	6"	ASME 150	1087	1604	1190	851	320	810	310
		ASME 300	1107						
		ASME 600	1157						
	DN150	PN 40	1059						

5.1.4 AU006 to AU080 (separately mounted models)

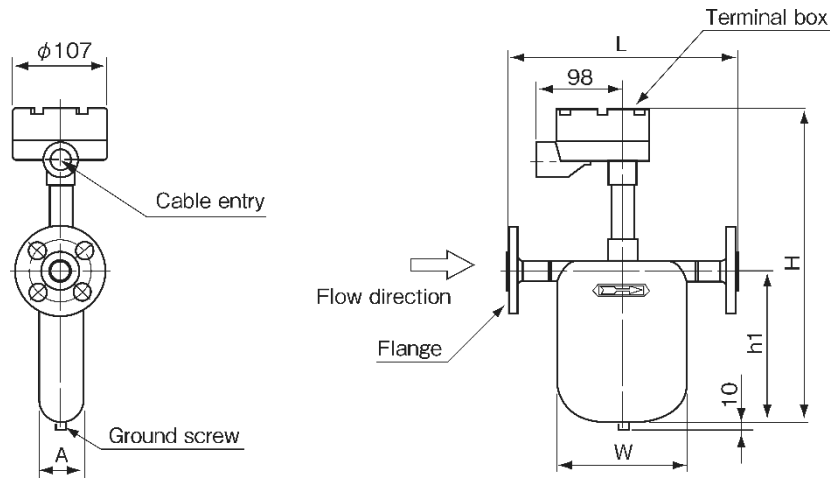

Fig. 5.6 Outline Dimensions of Separately Mounted Model (1/3)

Stainless steel models (316L)

Dimensions in millimeters

Model	Flange		L	H	h1	A	W	App. Weight (kg)
	Nom. size	Flange rating						
AU006	1/2"	ASME 150	268	324	180	53	148	4.0
		ASME 300	277					
		ASME 600	289					
	DN15	PN 40	247					
AU010	1/2"	ASME 150	282	362	218	53	163	4.7
		ASME 300	291					
		ASME 600	303					
	DN15	PN 40	261					
AU015	1/2"	ASME 150	325	412	268	65	205	5.6
		ASME 300	334					
		ASME 600	347					
	DN15	PN 40	305					

Alloy C-22 models

Model	Flange		L	H	h1	A	W	App. Weight (kg)
	Nom. size	Flange rating						
AU006	3/8"	ASME 150	286	324	180	53	148	4.0
		ASME 300						
		ASME 600						
AU010	1/2"	ASME 150	300	362	218	53	163	4.7
		ASME 300						
		ASME 600						
AU015	1/2"	ASME 150	344	412	268	65	205	5.6
		ASME 300						
		ASME 600						

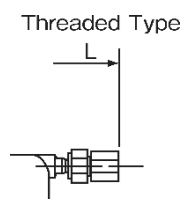

Fig. 5.7 Outline Dimensions of Separately Mounted Model (2/3)

Model	Screw connection	L	App. Weight (kg)
AU006	Rc3/8	296	2.8
AU010	Rc3/8	312	3.4
AU015	Rc3/4	382	4.2

Stainless steel models (316L)

Dimensions in millimeters

Model	Flange		L	H	h1	A	W	App. Weight (kg)
	Nom. size	Flange rating						
AU025	12	ASME 150	411	480	329	83	262	10.4
		ASME 300	424					
		ASME 600	437					
	DN25	PN 40	380					
AU040	1 · 1/2"	ASME 150	547	610	452	121	385	20
		ASME 300	560					
		ASME 600	575					
	DN40	PN 40	513					
AU050	2"	ASME 150	550	610	452	121	385	20
		ASME 300	563					
		ASME 600	582					
	DN50	PN 40	519					
AU080	3"	ASME 150	698	780	602	174	510	54
		ASME 300	717					
		ASME 600	737					
	DN80	PN 40	675					

Alloy C-22 models

Model	Flange		L	H	h1	A	W	App. Weight (kg)
	Nom. size	Flange rating						
AU025	12	ASME 150	444	480	329	83	262	10.4
		ASME 300						
		ASME 600						
AU040	1 · 1/2"	ASME 150	587	610	452	121	385	20
		ASME 300						
		ASME 600						
		ASME 150						
AU050	2"	ASME 300	587	610	452	121	385	20
		ASME 600						
		ASME 150						
AU080	3"	ASME 150	756	780	602	174	510	54
		ASME 300						
		ASME 600						

5.1.5 AU100 to AU15H (separately mounted models)

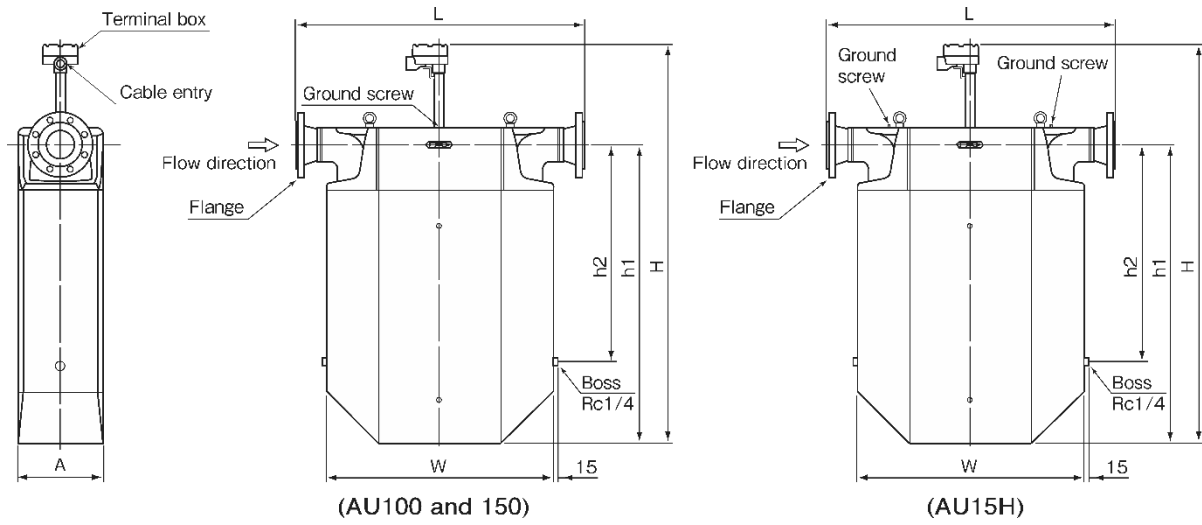

Fig. 5.8 Outline Dimensions of Separately Mounted Model (3/3)

Dimensions in millimeters

Model	Flange		L	H	h1	h2	A	W	App. Weight (kg)
	Nom. size	Flange rating							
AU100	4"	ASME 150	1018	1309	1015	660	300	810	231
		ASME 300	1036						
		ASME 600	1082						
	DN100	PN 40	994						
AU150	6"	ASME 150	1318	1309	1015	660	300	810	246
		ASME 300	1338						
		ASME 600	1388						
	DN150	PN 40	1290						
AU15H	6"	ASME 150	1087	1510	1190	851	320	810	310
		ASME 300	1107						
		ASME 600	1157						
	DN150	PN 40	1059						

5.1.6 L-Cor 8100 High Temperature Flowmeter (AU025 to AU150)

Transmitter separately mounted type/Flange connection type (AU025, AU040, AU050, AU080)

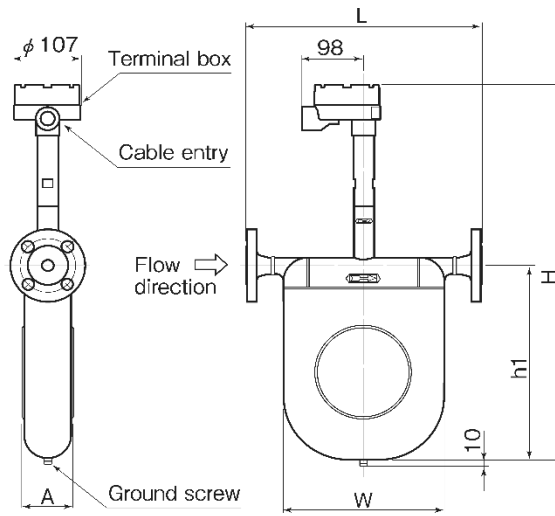

Fig. 5.9.1 Outline Dimensions of L-Cor 8100 High Temperature Flowmeter

Dimensions in millimeters

Model	Nom. size	ASME				DIN	H	h1	A	W	App. Weight (kg)
		150	300	600	PN 40						
		L									
L-Cor 8100	AU025	25 (1")	411	424	437	380	638	329	83	262	10.9
	AU040	40 (1 · 1/2")	547	560	575	513	768	452	121	385	20.3
	AU050	50 (2")	550	563	582	519					20.7
	AU080	80 (3")	699	717	737	675	960	602	174	510	54.1

Transmitter separately mounted type/Flange connection type (AU100, AU150)

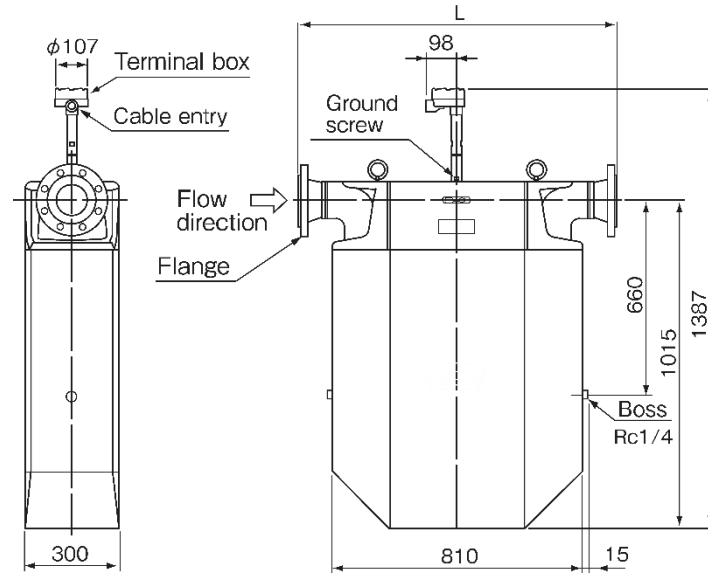

Fig. 5.9.2 Outline Dimensions of L-Cor 8100 High Temperature Flowmeter

Dimensions in millimeters

Model	Flange		L	App. Weight (kg)
	Nom. size	Flange rating		
AU100	4"	ASME 150	1018	231
		ASME 300	1036	
		ASME 600	1082	
	DN100	PN 40	994	
AU150	6"	ASME 150	1318	246
		ASME 300	1338	
		ASME 600	1388	
		DN150	PN 40	1290

5.1.7 L-Cor 8200 Cryogenic Flowmeter (AU025 to AU080)

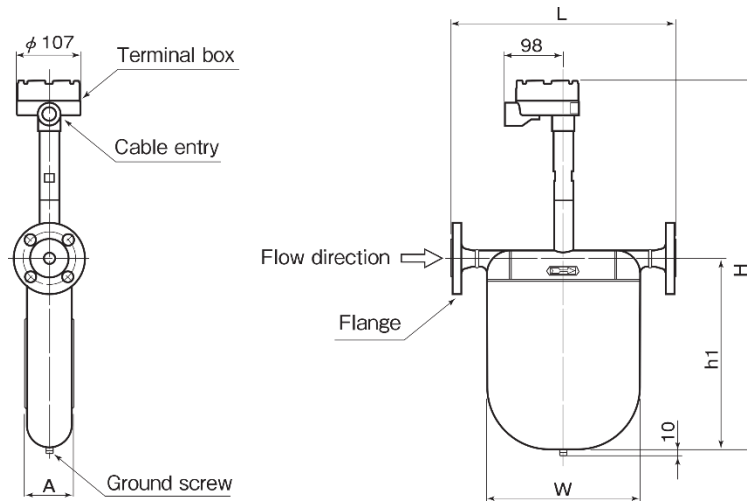

Fig. 5.10 Outline Dimensions of L-Cor 8200 Cryogenic Flowmeter

Stainless steel models (316L)

Dimensions in millimeters

Model	Flange		L	H	h1	A	W	App. Weight (kg)
	Nom. size	Flange rating						
AU025	1"	ASME 150	411	660	329	83	262	10.9
		ASME 300	424					
		ASME 600	437					
	DN25	PN 40	380					
AU040	1-1/2"	ASME 150	574	790	452	121	121	20.3
		ASME 300	560					
		ASME 600	575					
	DN40	PN 40	513					
AU050	2"	ASME 150	550	790	452	121	121	21
		ASME 300	563					
		ASME 600	582					
	DN50	PN 40	519					
AU080	3"	ASME 150	699	960	602	174	510	54
		ASME 300	717					
		ASME 600	737					
	DN80	PN 40	675					

Alloy C-22 models

Model	Flange		L	H	h1	A	W	App. Weight (kg)
	Nom. size	Flange rating						
AU025	1"	ASME 150	444	660	329	83	262	10.9
		ASME 300						
		ASME 600						
AU040	1-1/2"	ASME 150	587	790	452	121	121	20.3
		ASME 300						
		ASME 600						
AU050	2"	ASME 150	587	790	452	121	121	21
		ASME 300						
		ASME 600						
AU080	3"	ASME 150	756	960	602	174	510	54
		ASME 300						
		ASME 600						

5.1.8 L-Cor 8200 Cryogenic Flowmeter (AU100 to AU15H)

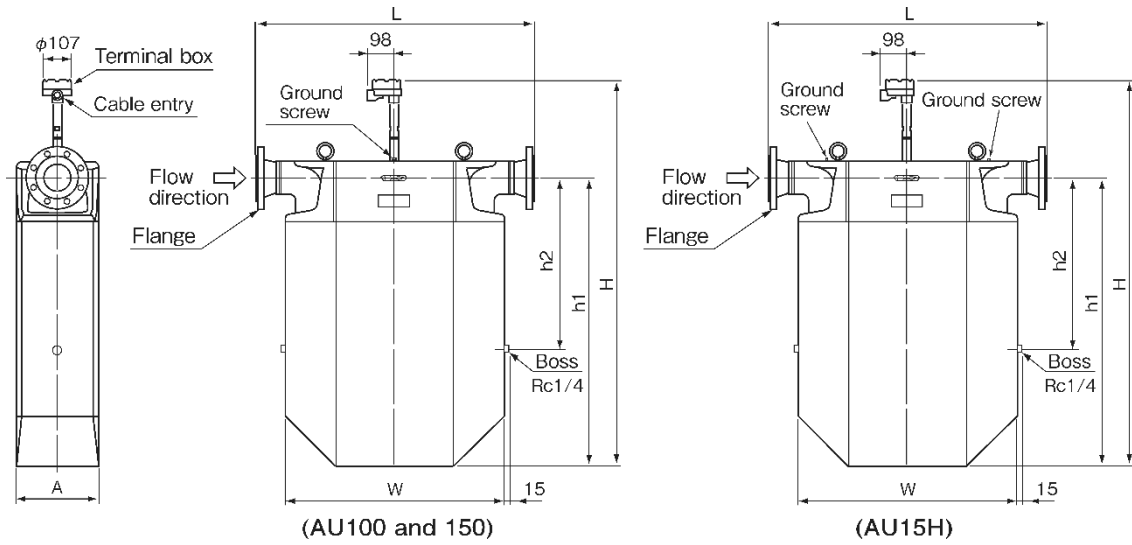

Fig. 5.11 Outline Dimensions of L-Cor 8200 Cryogenic Flowmeter (2/2)

Dimensions in millimeters

Model	Flange		L	H	h1	h2	A	W	App. Weight (kg)
	Nom. size	Flange rating							
AU100	4"	ASME 150	1018	1387	1015	660	300	810	231
		ASME 300	1036						
		ASME 600	1082						
	DN100	PN 40	994						
AU150	6"	ASME 150	1318	1387	1015	660	300	810	246
		ASME 300	1338						
		ASME 600	1388						
		DN150	PN 40						
AU15H	6"	ASME 150	1087	1588	1190	851	320	810	310
		ASME 300	1107						
		ASME 600	1157						
		DN150	PN 40						

5.1.9 Tri-Clamp Fitting Type

Integrally Mounted Type

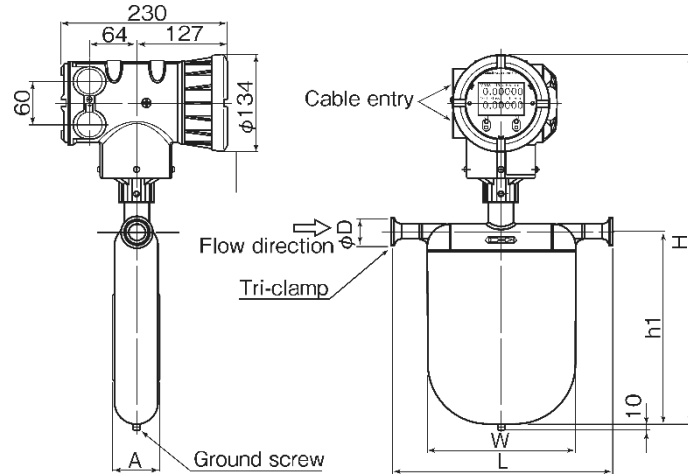

Fig. 5.12 Outline Dimensions of Integrally Mounted, Tri-clamp Type

Dimensions in millimeters

Model	Tri-clamp fitting		L	H	h1	A	W	φ D	App. Weight (kg)
	Nom. size	Connection							
AU006	10	Tri-clamp 10A	231.5	424	180	53	148	34	5.7
AU010	15	Tri-clamp 15A	256	462	218	53	163	34	6.3
AU015	15	Tri-clamp 15A	289	512	268	65	205	34	7.1
AU025	25	Tri-clamp 25 (ISO) IDF 1S	370	580	329	83	262	50.5	10.7
AU040	40	Tri-clamp 38 (ISO) IDF 1.5S	493	710	452	121	385	50.5	19
AU050	50	Tri-clamp 51 (ISO) IDF 2S						64	
AU080	80	Tri-clamp 76.1 (ISO) IDF 13S	658.5	880	602	174	510	91	51

Process connection: A in mm; S (sanitary) in inches.

Separately Mounted Type

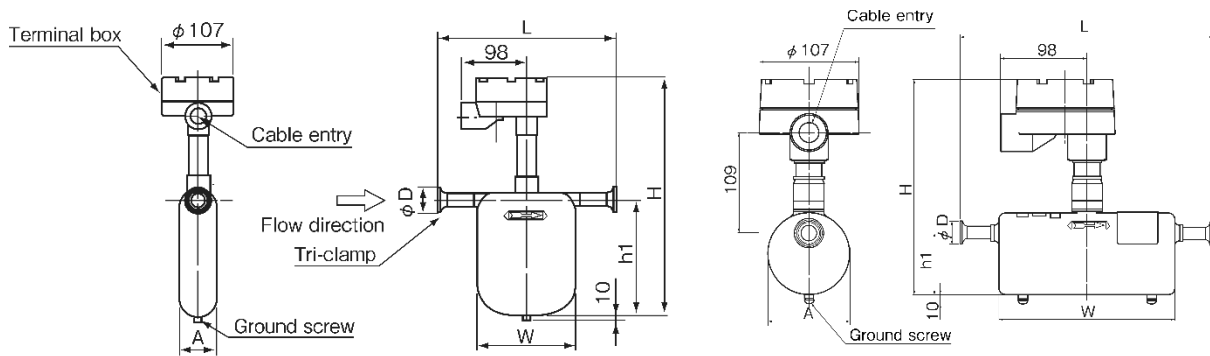

Fig. 5.13 Outline Dimensions of Separately Mounted, Tri-clamp Type

Dimensions in millimeters

Model	Tri-clamp fitting		L	H	h1	A	W	̕ D	App. Weight (kg)
	Nom. size	Connection							
AU003	10	Tri-clamp 10A	265	230	67	89.1	192	34	4.5
AU006	10	Tri-clamp 10A	231.5	424	180	53	148	34	2.8
AU010	15	Tri-clamp 15A	256	462	218	53	163	34	3.4
AU015	15	Tri-clamp 15A	289	512	268	65	205	34	4.2
AU025	25	Tri-clamp 25 (ISO) IDF 1S	370	580	329	83	262	50.5	7.8
AU040	40	Tri-clamp 38 (ISO) IDF 1.5S	493	710	452	121	385	50.5	16
AU050	50	Tri-clamp 51 (ISO) IDF 2S						64	
AU080	80	Tri-clamp 76.1 (ISO) IDF 13S	658.5	880	602	174	510	91	48

Process connection: A in mm; S (sanitary) in inches.

L-Cor 8200 Cryogenic Flowmeter (AU025 to AU080)

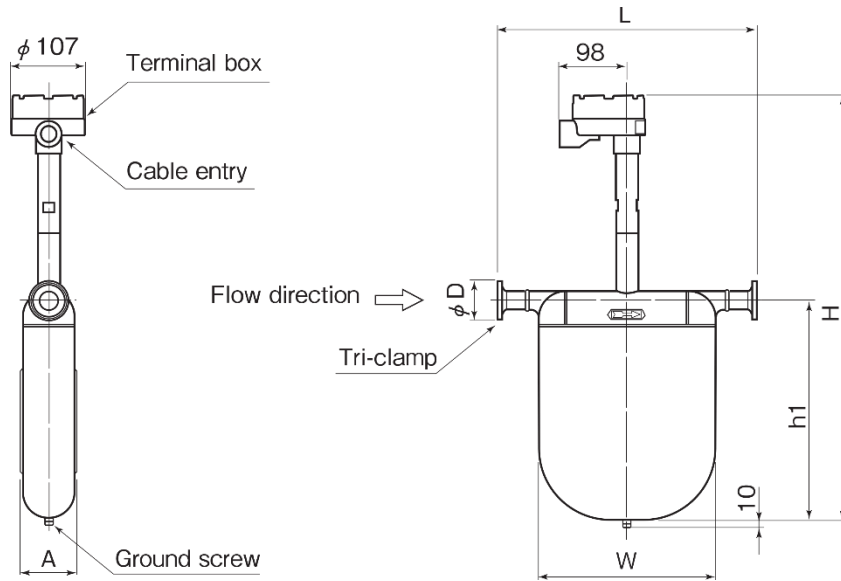

Fig. 5.14 Outline Dimensions of Separately Mounted, Tri-clamp Type (L-Cor 8200 Cryogenic Flowmeter)

Model		Tri-clamp fitting		L	H	h1	A	W	φ D	App. Weight (kg)
		Nom. size	Connection							
L-Cor 8200	AU025	25	Tri-clamp 25 (ISO) IDF 1S	370	660	329	83	262	50.5	8.3
	AU040	40	Tri-clamp 38 (ISO) IDF 1.5S	493	790	452	121	385	50.5	17
	AU050	50	Tri-clamp 51 (ISO) IDF 2S						64	
	AU080	80	Tri-clamp 76.1 (ISO) IDF 3S	658.5	960	602	174	510	91	48

Process connection: A in mm; S (sanitary) in inches.

5.2 L-Cor 6000

5.2.1 Integral mounted models

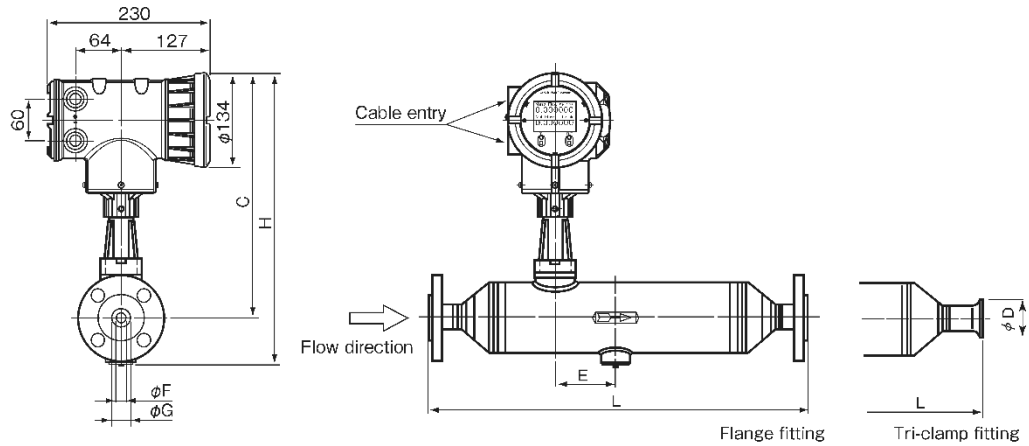

Fig. 5.15 Outline Dimensions of Integrally Mounted, Titanium Tube Type

Dimensions in millimeters

Model	Nom. size		L		H	C	ϕF	ϕG	E	ϕD (Tri-clamp)	App. Weight (kg)
	Flange	Tri-clamp	Flange	Tri-clamp							
	ASME	ISO, IDF	ASME	Tri-clamp							
AS010	1/2"	10mm	458	426	390	340	6.3	11.4	69	34	10
AS015	1/2"	15mm	496	464			9.3	16.8	80		11
AS025	1"	1-1/2S	570	529	423	353	15.4	26.6	88	50.5	18
AS040	1-1/2"	2S	749	716	439	359	22.3	40.4	112	64	28
AS050	2"	2-1/2S	919	882	474	372	30.5	52.6	153	77.5	38
ASR50	3"	3-1/2S	1073	1032				77.8		106	40

NOTES:

- * Loose flange is applied.
- * Tri-clamp connections of all models comply with ISO2852.
- * Nominal size S: Inch Sanitary version

5.2.2 Separately mounted models

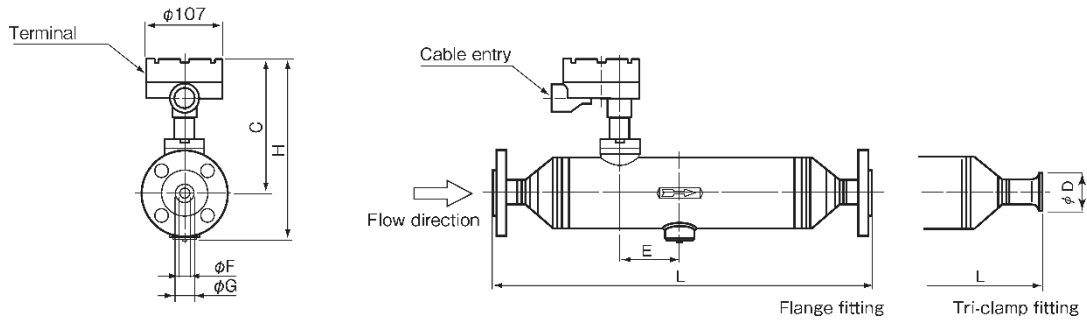

Fig. 5.16 Outline Dimensions of Separately Mounted, Titanium Tube Type

Dimensions in millimeters

Model	Nom. size		L		H	C	φ F	φ G	E	φ D (Tri-clamp)	App. Weight (kg)
	Flange	Tri-clamp	Flange	Tri-clamp							
	ASME	ISO, IDF	ASME 150								
AS010	1/2"	10mm	458	426	246	197	6.3	11.4	69	34	7
AS015	1/2"	15mm	496	464			9.3	16.8	80		8
AS025	1"	1·1/2S	570	529	280	210	15.4	26.6	88	50.5	15
AS040	1·1/2"	2S	749	716	296	216	22.3	40.4	112	64	25
AS050	2"	2·1/2S	919	882	332	229	30.5	52.6	153	77.5	35
ASR50	3"	3·1/2S	1073	1032				77.8		106	

NOTES:

- * Loose flange is applied.
- * Tri-clamp connections of all models comply with ISO2852.
- * Nominal size S: Inch Sanitary version

5.3 L-Cor 4000

5.3.1 Integrally mounted models

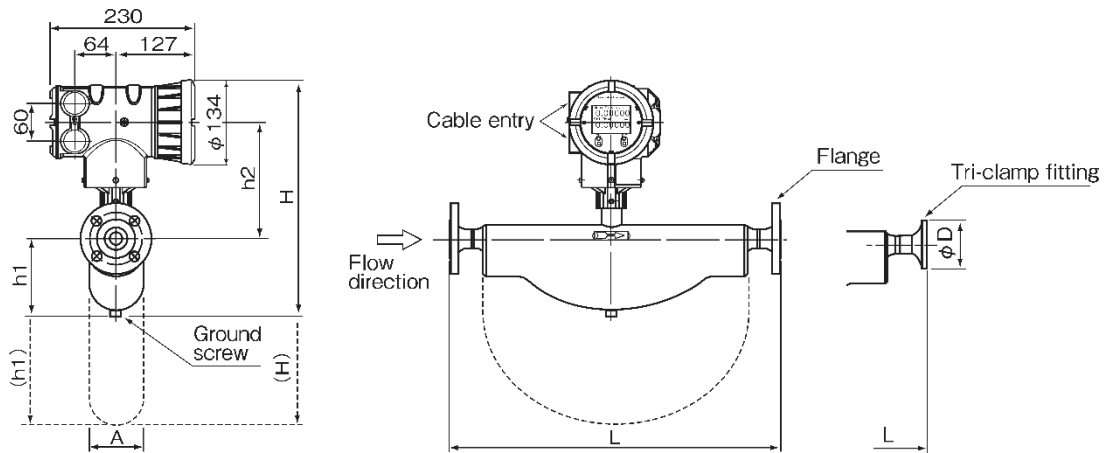

Dotted lines show sensor unit exterior case dimension of AB040 and 050.

Fig. 5.21 Outline Dimensions of Integrally Mounted Model

Dimensions in millimeters

Model	Nom. size	ASME			H	h1	h2	A	App. Weight (kg)
		150	300	600					
		L							
AB006	10 (1/2")	369	378	390.5	354	94	192	59	7.3
AB010	15 (1/2")	406	415	427.5	350	94	189	59	7.6
AB015	15 (1/2")	512	521	533.5	441	168	206	91	11.6
AB025	25 (1")	601	613	626	436	175	194	91	14.2
AB040	40 (1-1/2")	660	673	688.5	588	323	197	125	32.8
AB050	50 (2")	663	676	695	588	323	197	125	33.2

Dimensions in millimeters

Model	Tri-clamp fitting			
	Process connection	L	ϕD	App. Weight (kg)
AB006	Tri-clamp 10A	333	34	5.2
AB010	Tri-clamp 15A	380	34	6.1
AB015	Tri-clamp 15A	476	34	9.9
AB025	Tri-clamp 25 (ISO), IDF 1S	559	50.5	11.1
AB040	Tri-clamp 38 (ISO), IDF 1.5S	606	50.5	29.3
AB050	Tri-clamp 51 (ISO), IDF 2S	606	64	29.3

Process connection: A in mm; S (sanitary) in inches.

5.3.2 Separately mounted models

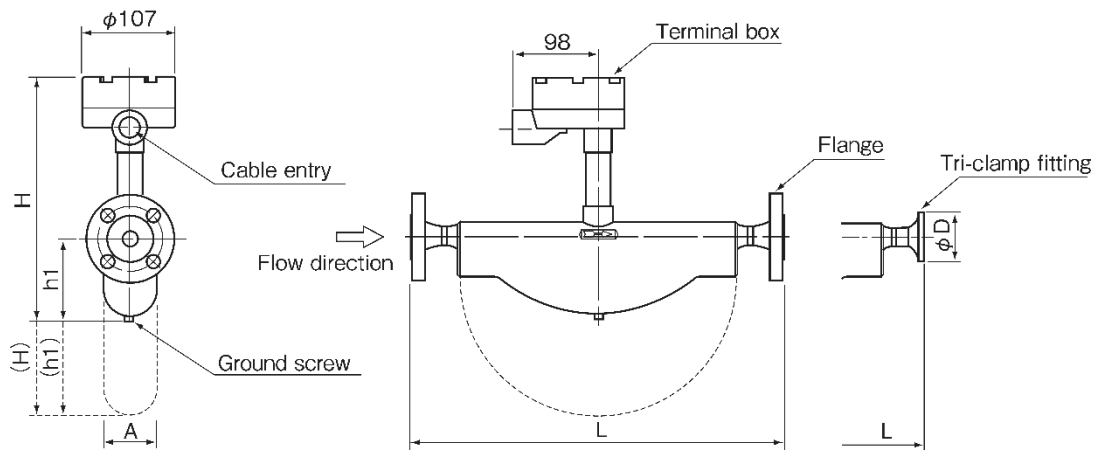

Dotted lines show sensor unit exterior case dimension of AB040 and 050.

Fig. 5.22 Outline Dimensions of Separately Mounted Model

Dimensions in millimeters

Model	Nom. size	ASME			H	h1	A	App. Weight (kg)
		150	300	600				
		L						
AB006	10 (1/2")	369	378	390.5	257	94	59	4.7
AB010	15 (1/2")	406	415	427.5	254	158	59	5.0
AB015	15 (1/2")	512	521	533.5	345	168	91	9.0
AB025	25 (1")	601	613	626	340	175	91	11.6
AB040	40 (1-1/2")	660	673	688.5	491	323	125	30.2
AB050	50 (2")	663	676	695	491	323	125	30.6

Dimensions in millimeters

Model	Tri-clamp fitting			
	Process connection	L	φ D	App. Weight (kg)
AB006	Tri-clamp 10A	333	34	2.6
AB010	Tri-clamp 15A	380	34	3.5
AB015	Tri-clamp 15A	476	34	7.3
AB025	Tri-clamp 25 (ISO), IDF 1S	559	50.5	8.5
AB040	Tri-clamp 38 (ISO), IDF 1.5S	606	50.5	26.7
AB050	Tri-clamp 51 (ISO), IDF 2S	606	64	26.7

Process connection: A in mm; S (sanitary) in inches.

5.4 Separately Mounted Transmitter

5.4.1 Stanchion Mounting

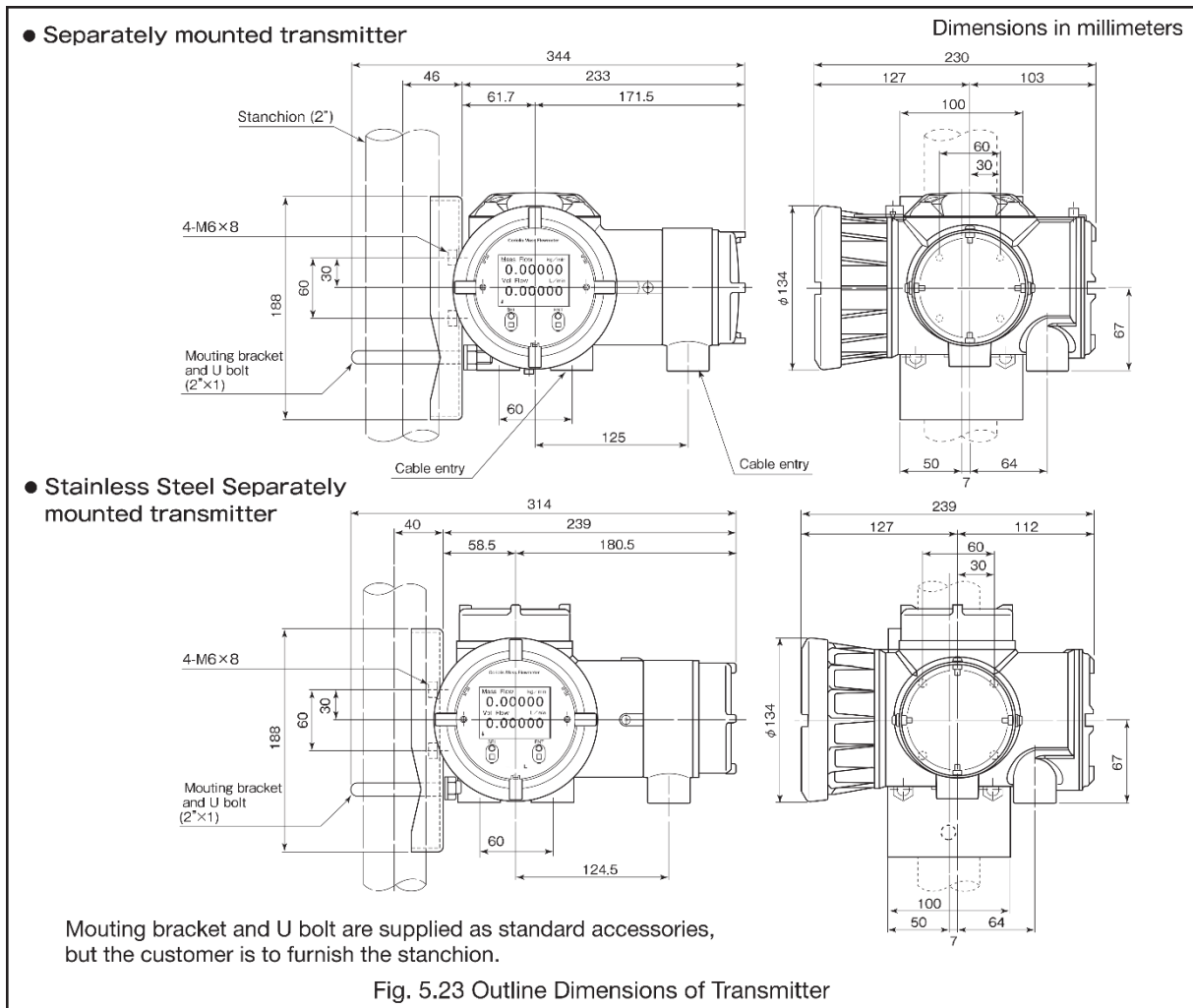

6 Installation

6.1 General Installation Guidelines

- (1) Select a location easy to access for inspection and maintenance.
- (2) Avoid a location subject to excessive temperature variation and vibration.
- (3) Avoid direct exposure to the sun. (Provide a sunshade or similar protection to keep the meter out of exposure to direct sunlight if necessary.)
- (4) Avoid a location where immersion in water is a possibility.
- (5) Select a location free from an atmosphere of corrosive gases.
- (6) Location should be free from dust and mist.
- (7) Separate at least one meter from sources of electromagnetic induction, such as large transformers and motors. Also, keep the meter away as far as possible from the sources of severe vibration, such as motors and pumps.
- (8) To ensure consistent and accurate measurement, adhere to the instructions in 6.2 Physical Orientation, 6.3 Installation Location, 6.4 Installation Guidelines, and 6.6 Installing Proper Pipe Supports.
- (9) The Coriolis flowmeter requires an installation location where pipeline

oscillation is held below 0.3G to ensure consistent and accurate measurement. External vibration (including pulsation) particularly with the same frequency as the drive frequency of the measuring pipe may affect the measurement. Contact Anton Paar regarding drive frequency of each model.

- (10) Locate the control valve downstream of the flowmeter. Where cavitation is likely to occur, install the flowmeter at least five meters away.

6.2 Physical Orientation

6.2.1 L-Cor 8000 Physical Orientation

(1) The sensor may be installed either in a horizontal run or vertical run. The following physical orientations are suggested, depending on the type of process fluid. [Orientation (2) shows the typical orientation for liquids.]

(2) If cable entry points upwards, there must be adequate provisions for sealing off or preventing rainwater and other moisture from entering the meter.

● AU003 to AU15H

Physical orientation	Horizontal pipeline		Vertical pipeline
	(1)	(2)	
			
Applicable fluids	<ul style="list-style-type: none"> • Slurries (If deposit buildup is likely.) 	<ul style="list-style-type: none"> • Liquid 	<ul style="list-style-type: none"> • Liquid • Liquids that require cleansing • Liquids that tend to foam

Fig. 6.1

(3) Transmitter orientation is correct if its display face is not in the horizontal plane.

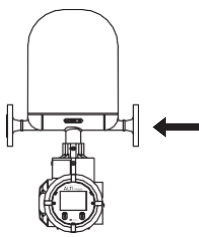
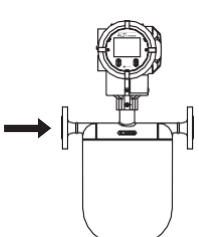
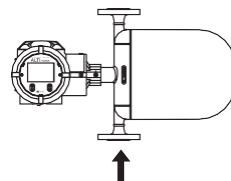
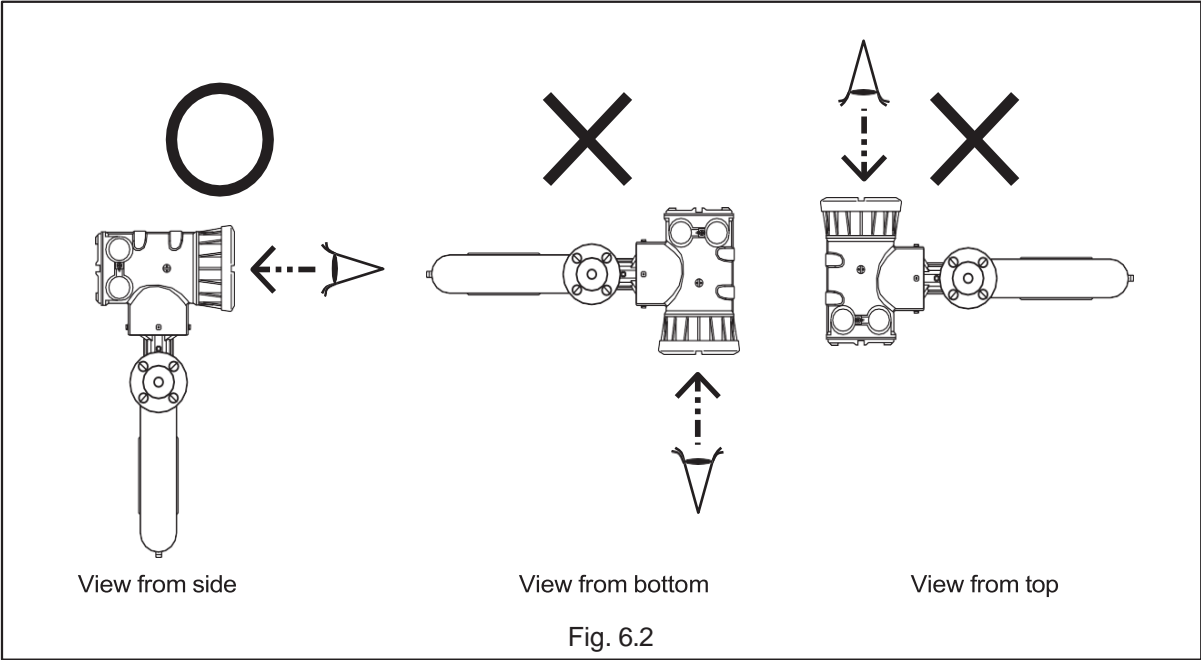

(4) For the orientation of separately mounted transmitter, see 6.9 Separately Mounted Transmitter Installation.

● **AU00A and AU001**

Installation on a bench or wall are acceptable. We recommend the following orientations:

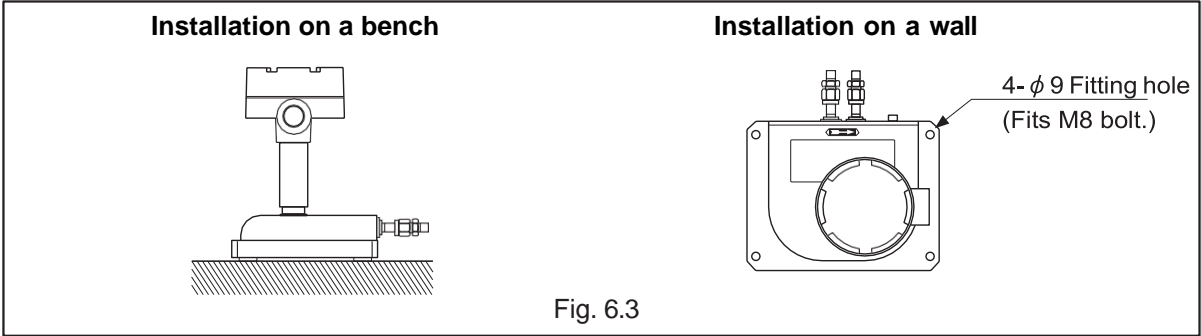

NOTE: For wall mounting, secure the body with bolts, making use of sensor unit fitting holes.

6.2.2 L-Cor 6000 Physical Orientation

NOTE: Please refer to Item-12 for EHEDG Authentication Article.

- (1) The flowmeter may be installed either in a horizontal line or a vertical line.
- (2) Where cleansing is required or where air bubble entrapment is likely, we suggest installation in a vertical run.
- (3) If cable entry points upwards, take necessary measures to prevent rain and water from entering the meter.
- (4) Transmitter installation is correct if its display face is not in the horizontal plane.
- (5) For the orientation of separately mounted transmitter, see 6.9 Separately Mounted Transmitter Installation.

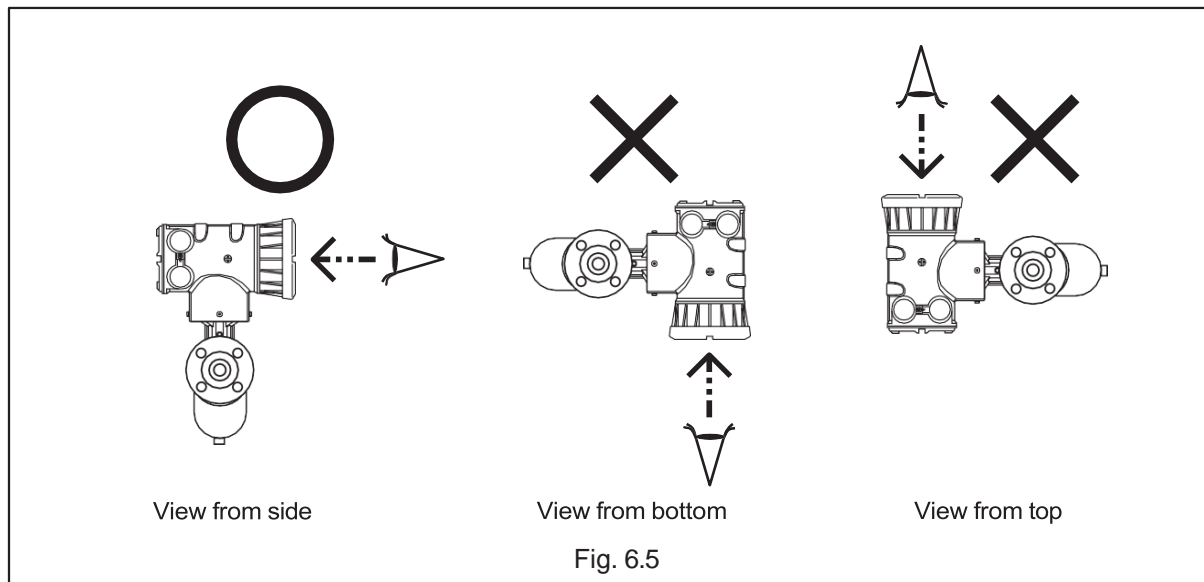
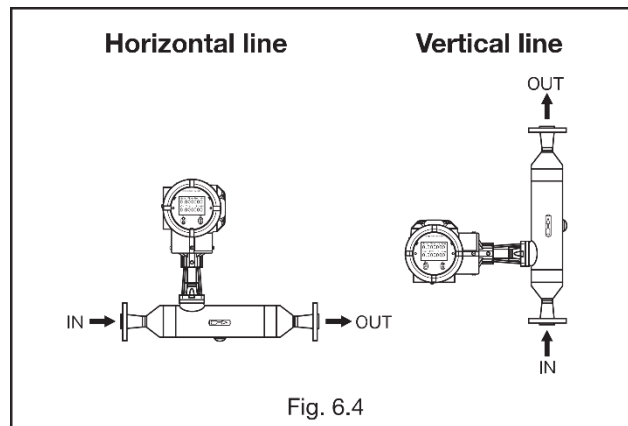

CAUTION:

EHEDG certification specifications:

The mounting position is the vertical mounting only. (Fig.6.4 right picture "Vertical line": self-drain required). The CIP (Cleaning In Place) conditions: Perform at a flow velocity of 1.5 m/s or more. Process connections: ISO 2852 Ferrule joint only. Gasket: ISO 2852 In combination with T-ring seals from Combifit International B.V.

6.2.3 L-Cor 4000 Physical Orientation

- (1) The flowmeter may be installed either in a horizontal line or a vertical line.
- (2) Where cleansing is required or where air bubble entrapment is likely, we suggest installation in a vertical run.
- (3) If cable entry points upwards, take necessary measures to prevent rain and water from entering the meter.
- (4) Transmitter installation is correct if its display face is not in the horizontal plane.
- (5) For the orientation of separately mounted transmitter, see 6.9 Separately Mounted Transmitter Installation.

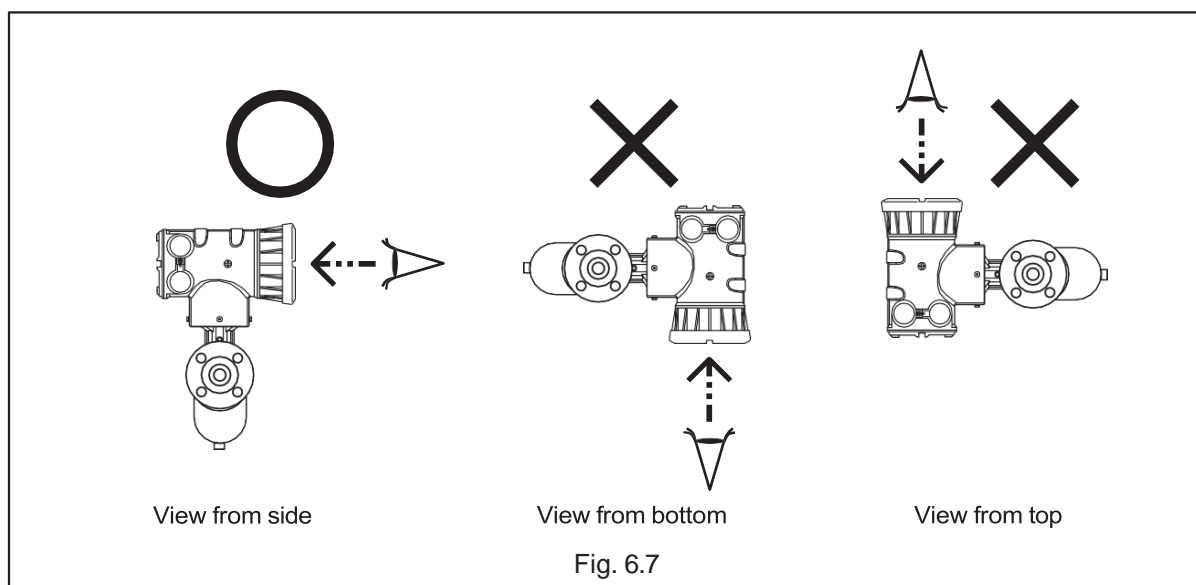
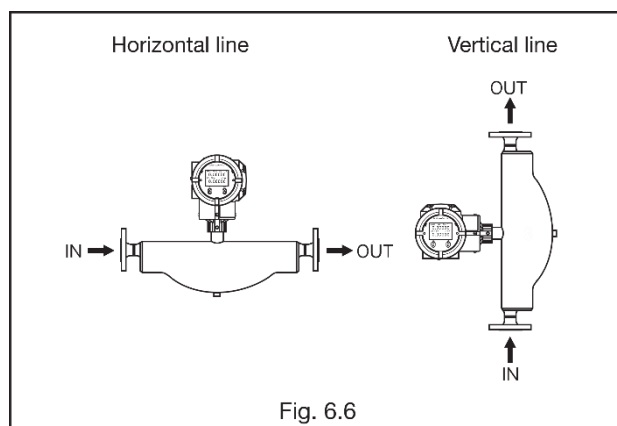

6.3 Installation Location

Because air bubbles in the flow tube produce a loss of meter accuracy, avoid the following installation or practice.

- Locating the flowmeter at the highest point in the piping system.
- In a vertical piping system, directly discharging the metered fluid from the piping system without the provision of a valve or similar controlling device.

(While L-Cor 8000 meter is used in the installation examples below, the same applies to L-Cor 6000 and 4000.)

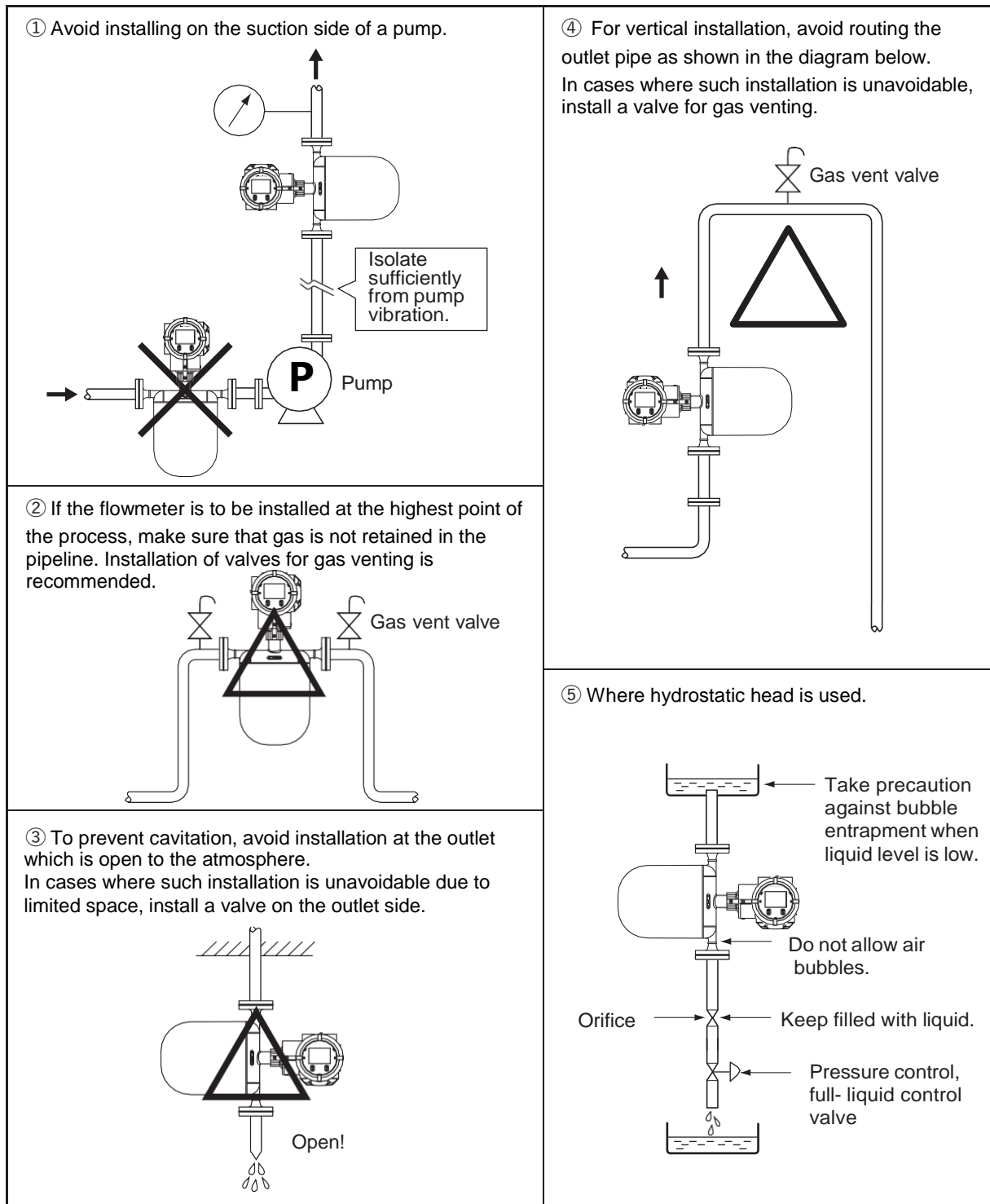

Fig. 6.8

6.4 Piping Installation Guidelines

6.4.1 Standard piping conditions

- (1) A Coriolis mass flowmeter is unaffected by the flow pattern of process fluid. Basically, therefore, it does not require any flow straightener. However, connection to a piping with different diameter should be done using a concentric reducer or tapered pipe.
- (2) Locate the meter sufficiently away from sources of vibration and pulsations.
- (3) For use in zeroing, a valve that can shut off the process flow completely should be provided downstream of the meter. (For maintenance purposes, installation of another valve upstream of the meter is recommended.)
- (4) Avoid giving pipe stress on the sensor.

L-Cor 8000 standard piping conditions

(While L-Cor 8000 meter is used in the installation examples below, the same applies to L-Cor 6000 and 4000.)

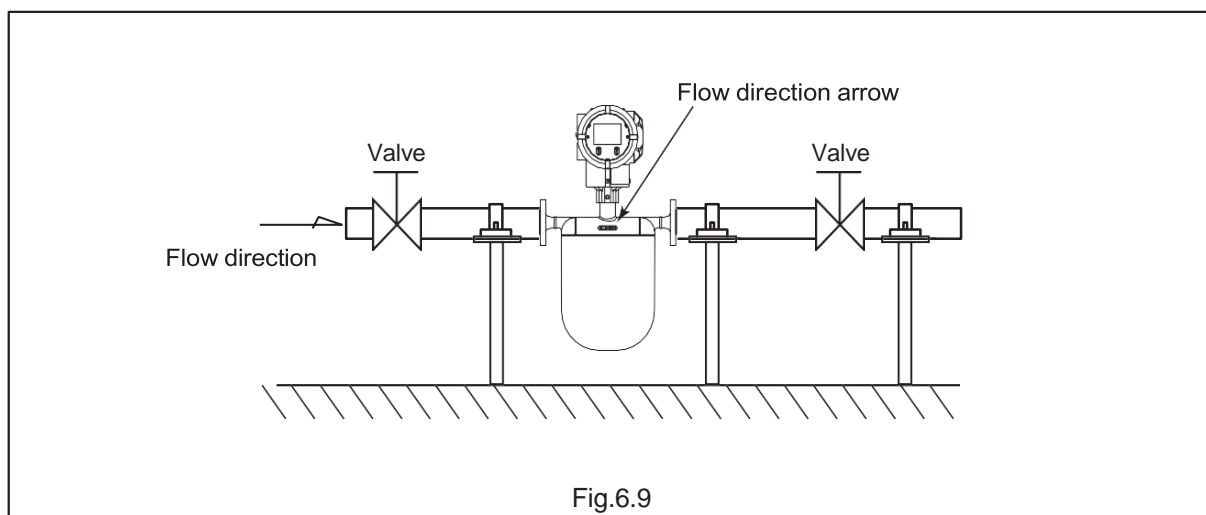

Fig.6.9

⚠ CAUTION: This meter is designed for flange mounting. It should be supported on the part of the pipeline. Do not support the sensor body. Although models AU00A and AU001 are designed to be sensor-body mounting, make sure to provide the piping support both upstream and downstream of the meter.

6.4.2 Influence of vibration and pulsation

Generally, Coriolis mass flowmeters can best perform in measurements with least pipeline vibration and pulsation. In applications where vibration and pulsation are not negligible, the following considerations must be considered:

- (1) Locate the meter sufficiently away from the sources of vibration and pulsation.
- (2) Provide attenuators, such as flexible tubes and chambers. However, if these elements are caused to vibrate by the drive of the flowmeter, take measure such as keeping these elements away from the flowmeter to avoid zero shifts.
- (3) Close shutoff valves upstream and downstream of the meter at process flow shutdown. (This is to prevent erratic signal generation at shutoff. Bear in mind, however, to prevent pressure buildup inside from exceeding the max allowable pressure of the meter.)
- (4) If meters of the same kind are to be installed in the same pipeline, locate them sufficiently apart (at least five times the face-to-face dimension of the meter).

6.4.3 Prevention of Cavitation

Cavitation can cause a loss of meter accuracy in measurement. Maintain line pressures that will not cause cavitation upstream and downstream of the meter for this reason. Avoid making such an arrangement as to open the line to the atmosphere immediately downstream of the meter. Care must be taken particularly in handling liquids of high steam pressure.

In practice, recommended minimum backpressure (downstream pressure) of the meter is calculated by the formula:

$$P_d = 3\Delta P + 1.3P_v$$

where:

P_d : Downstream pressure (MPa [absolute])
 ΔP : Pressure loss across the flowmeter (MPa)
 P_v : Steam pressure of the liquid at the temperature of measurement (MPa [absolute])

6.4.4 Prevention of Excessive Flows

⚠ CAUTION: Exceeding the meter's maximum flowrate will not significantly reduce the meter's long-term durability. Bear in mind, however, that the output will be clamped at 110% of the allowable full scale flowrate.

6.4.5 Prevention of Gas Mixed Flows

Slug flows (gases exist in the process liquid) are generally not measurable at a high degree of accuracy. It also causes erratic pulse generation at shutdown of the flow.

6.4.7 Bypass Loop

To facilitate maintenance and servicing, providing a bypass loop is recommended.

● L-Cor 8000 (AU003 to AU15H), L-Cor 6000 and L-Cor 4000

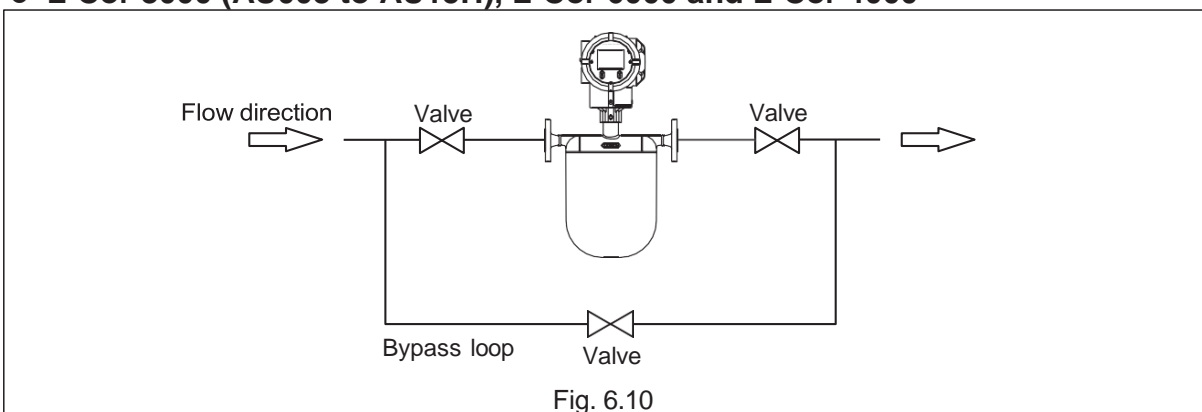

This transmitter is capable of detecting gas mixed flows. On finding the result of densitometer measurement exceeding 0.3 to 2g/mL (default setting for liquid measurement), the meter interprets it as a slug flow and reduces the instant flowrate to zero, interrupting the flow output.

For details about setting and operation of the gas mixed flow detection function, see 9.17 Gas Mixed Flow Alarm.

6.4.6 Keeping the Sensor filled with Process Liquid

⚠ CAUTION: The sensor must be filled with the process fluid during measurement. A partially filled meter results in large errors particularly at zeroing.

For models AU100 to AU15H installed on the horizontal pipeline, it is difficult to wash away air bubbles in the flow tube at flow rates below 10% of Max service flow rate (water used as the metered fluid). In such cases, run the fluid at flow rate greater than 10% of Max service flow rate first, then adjust the flow rate to the required rate.

Even with the flow rate greater than 10% of Max service flow rate, it will take approx. 40 seconds to completely fill the flow tube from its empty state (water used as the metered fluid).

Expansion of the process fluid due to freezing may damage the measuring pipe. Take measures to prevent process fluid from freezing

● L-Cor 8000 (AU00A and AU001)

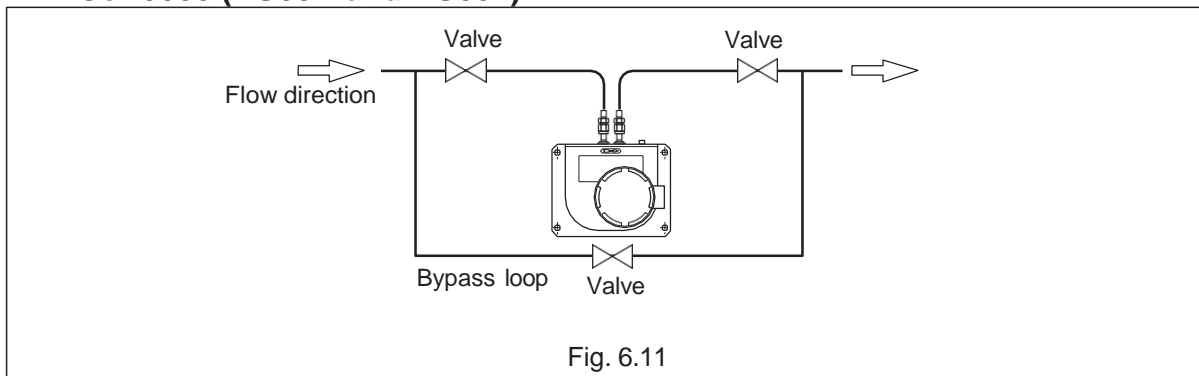

6.5 Flange Installation Guidelines

6.5.1 Flange Type

In order to avoid strains on sensor flanges, be sure to correct the flange face-to-face dimension, tilt and off-center alignment of pipes immediately before and after the sensor.

- (1) Make sure of the flow direction by referring to the flow direction plate.
- (2) Align the sensor flange O.D. with the flange O.D. of the pipeline, install gaskets, and tighten hex bolts evenly.

⚠ CAUTION: Remove, before installation, protective seals on sensor flanges that are attached before shipment from factory.

⚠ CAUTION: Models AU100 and AU150 weigh approx. 250kg, AU15H weights 340kg.

Installation (removal) involves risks. For safety reasons, make sure that qualified personnel (slinging workers) perform work of crane operation (Take into consideration your local law).

Shown in Fig. 6.13 is the center of gravity of equipment. When working with a vertical run in particular, carefully review proper slinging position, etc. with its weight and center of gravity in mind.

Incidentally, two M20 (AU100 to AU15H) eyebolts (made of SUS304) are installed in the housing of sensor unit (two places). Since eyebolts can become loose and come off with time due to vibration, it is good practice to retighten firmly or remove upon installation in the piping assembly.

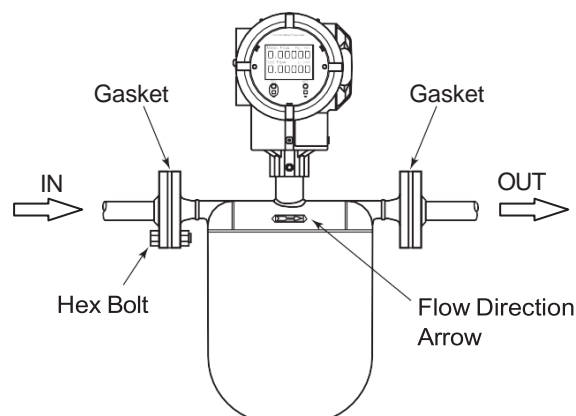

* While L-Cor 8000 meter is used in the figure, the same applies to L-Cor 6000 and L-Cor 4000.

Fig. 6.12

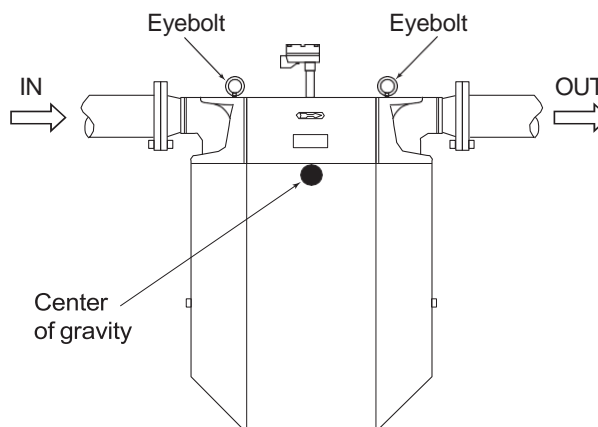

Fig. 6.13

6.5.2 Sanitary fitting type

The sanitary fitting type is of clamp connections. Using pipe fittings (option), install according to the procedure given below.

(1) Welding the companion sleeve (weld ferrule)

Weld the companion sleeves furnished to the piping. Pay attention to the perpendicularity of ferrule end face and difference in height at the weld.

As piping material, use G 3447 "Stainless Steel Sanitary Tubes".

(2) Installation

Sandwich the gasket between the sensor and ferrule and tighten with the clamp. Be sure to install the gasket in line with the groove in the ferrule end face before tightening up.

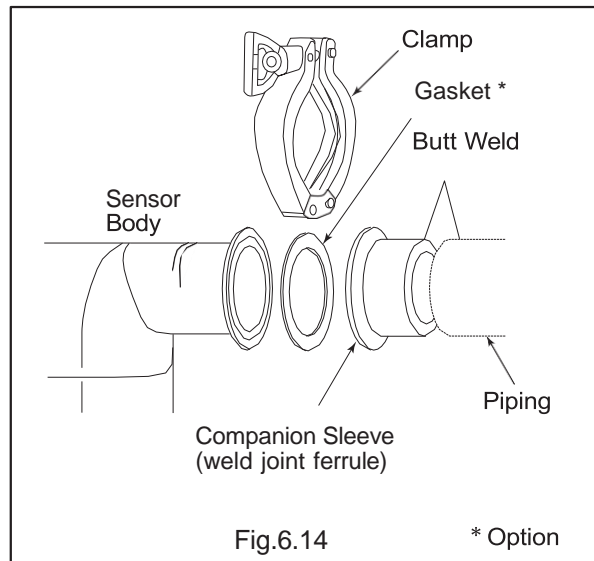

6.5.3 Threaded type

(1) AU00A and AU001

Install a Threaded fitting (R1/4) onto the piping, fit an O-ring between the end of piping and the gland of sensor unit, and then tighten them firmly.

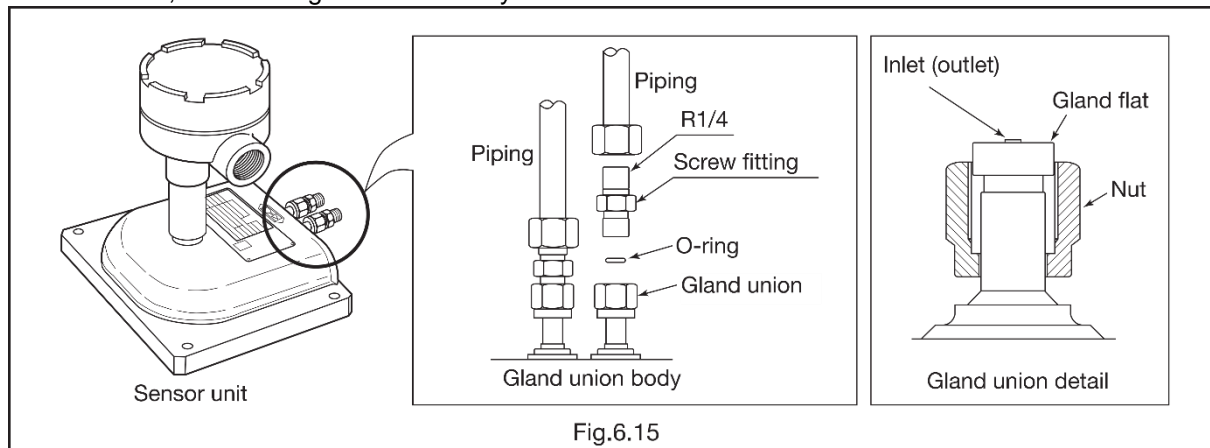

⚠ CAUTION:

1. Be careful to avoid damaging the gland flat and the protrusion of flow inlet (outlet).
2. Exercise care not to overtighten the nut. Overtightening can damage the gland flat.

(2) AU003 to AU015

Sandwich an O-ring between the probe and union fitting and tighten.

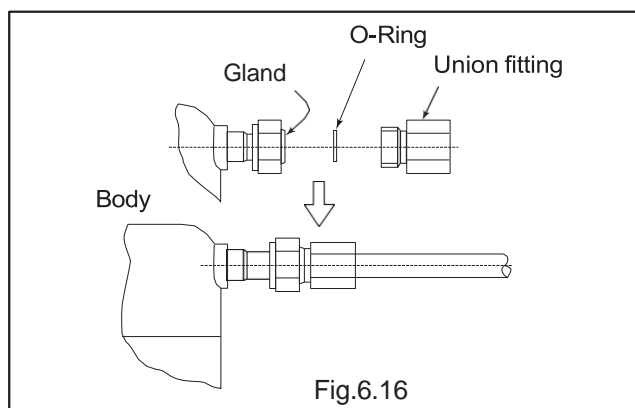

6.6 Installing Proper Pipe Supports

If pipeline oscillation is large or for accurate measurement on low flows, consider the following:

- (1) Provide pipe supports in the range shown below preferably with pipes clamped arranged symmetrically both upstream and downstream of the sensor.
- (2) Clamp the pipeline securely without using rubber bushings or similar cushioning material intended for the absorption of shock and vibration.
- (3) While it is necessary that the rigidity of clamps supporting upstream and downstream piping, pedestal, floor, etc. that hold individual supporting members be sturdy enough to bear their weight, it is more important to secure and maintain the overall rigidity of the entire structure. In large sized installations in particular, changes in the spring elements present in the area surrounded by dot lines in Fig. 6.18 due to exposure to thermal stress, line pressure, shocks, aging, and other contributing factors can cause zero shifts.

⚠ CAUTION: Support the pipeline with hold-down clamps; never hold down the sensor unit.

6.6.1 L-Cor 8000 pipe supports

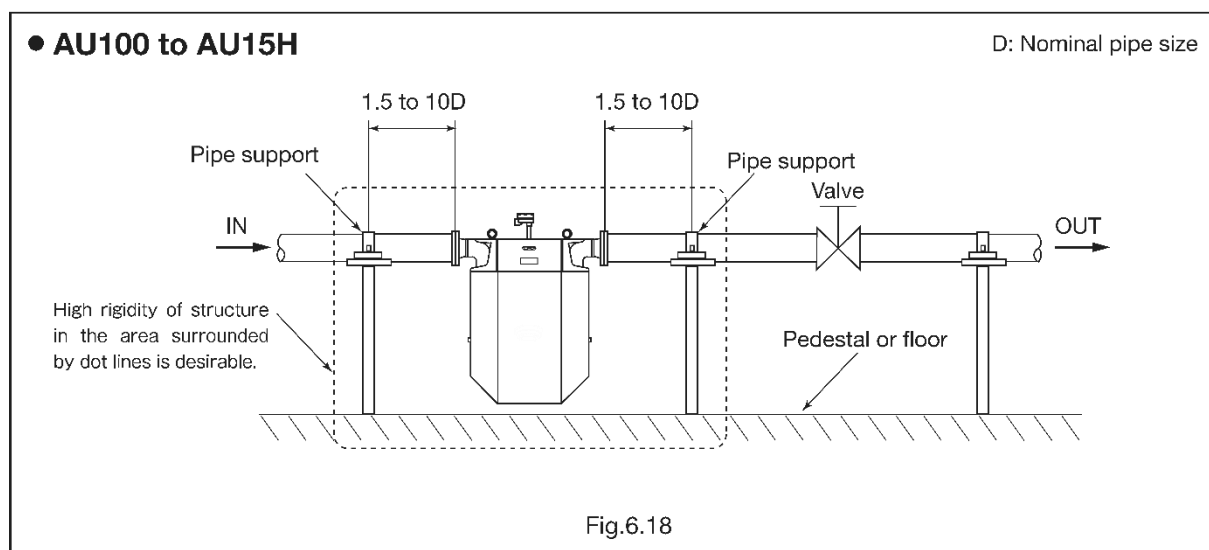
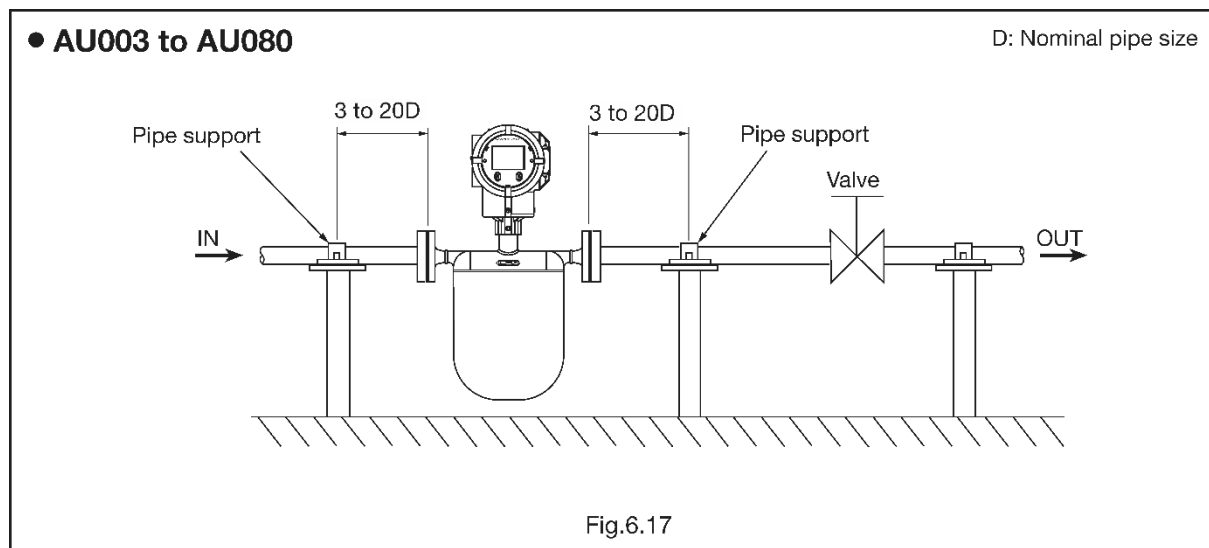

6.6.2 L-Cor 6000 pipe supports

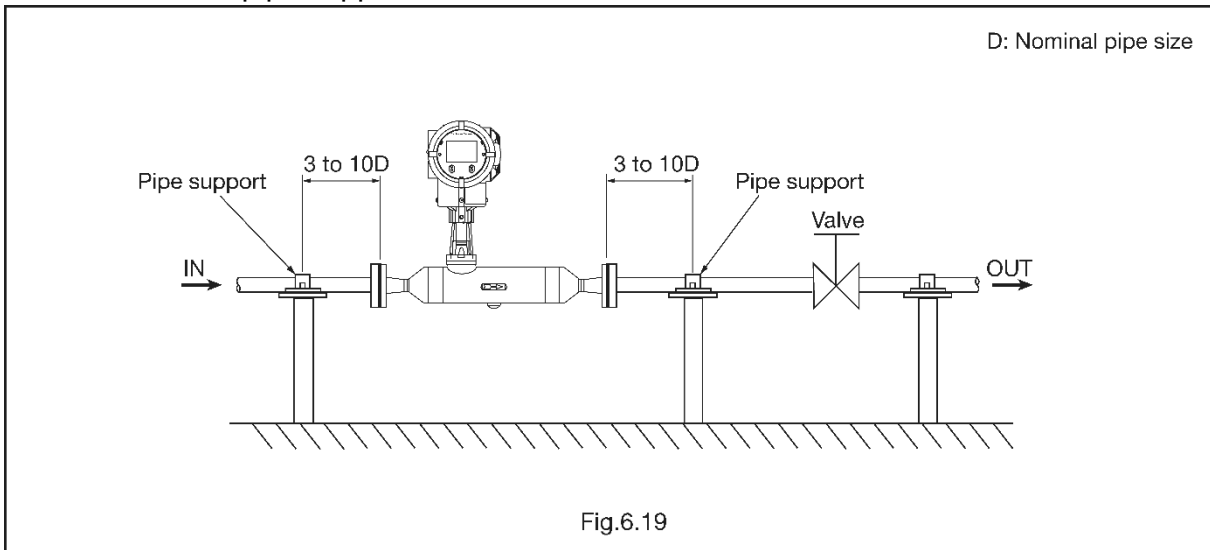

6.6.3 L-Cor 4000 pipe supports

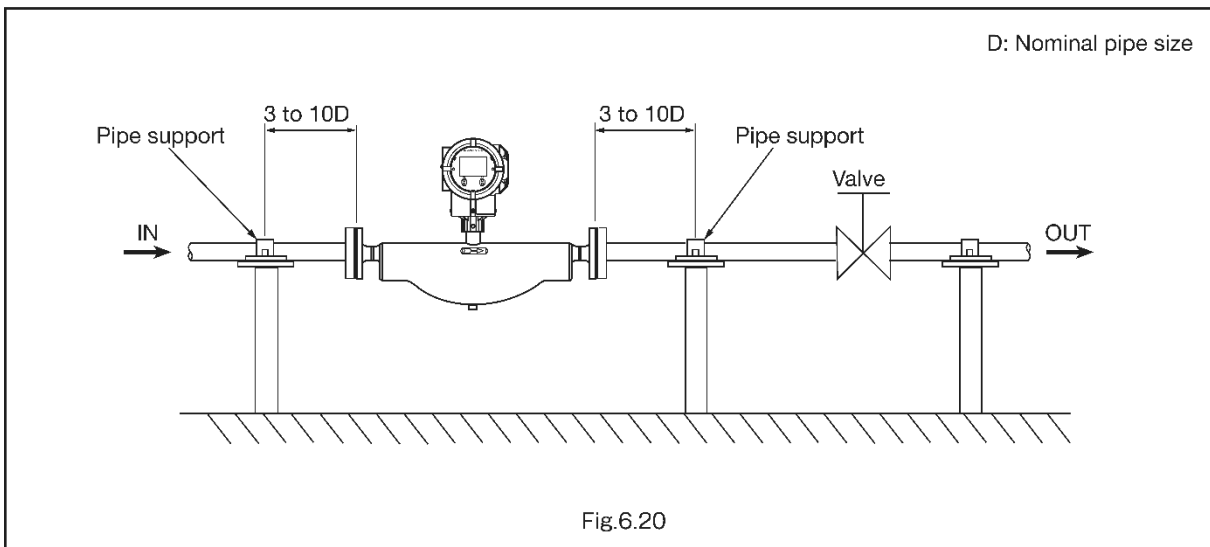

6.7 Heat and Cold Retention Procedures

When the fluid to be measured requires temperature retention at low or high temperature, you can keep the sensor unit at high or low temperature. Here, correct heat retaining and cold retaining methods are described.

- (1) When installing heat retaining or cold retaining material on the sensor unit, apply heat retention or cold retention to only main body. As the fluid passes through the sensor case, heat retention or cold retention on the mounting tube and terminal box has no effect. Especially, in the case of high temperature type and low temperature explosion-proof type, do not install heat retaining or cold retaining material within a distance of 20mm from the mounting tube so that the terminal box is protected against heat (heat and cold) (see Fig. 6.22).
- (2) For easy maintenance, a simplified heat retaining system is recommended on the sensor unit.

- (3) When covering the heat insulating material with outer sheath for heat retention or cold retention, if the natural frequency of the outer sheath is close to the frequency of the tube oscillating in the sensor unit *1, it may possibly cause some effect on the measurement.
- (4) Careful attention should be paid to the maximum permissible temperature when steam trace is applied. Trace temperature should be the same as that of the metered fluid. (⇒ see 3.1 Sensor Unit General Specifications).
- (5) If you plan to spirally wind copper tubing or similar around the sensor unit, secure the copper tubing with pipe retainers shown in Figs. 6.21 through 6.25 - and spot weld the copper tubing to the sensor unit.
- (6) Use of heat tracer is recommended for AU025, AU040, AU050, and AU080 of L-Cor 8000.

*1 : The frequency band for AU100 to AU15H will be 70 to 100Hz.

NOTE:

- Vibrating copper tubing caused by the flowmeter in operation can produce zero shifts. In such a case, increasing the number of fixed points is one solution that will work.
- To minimize transmission of oscillation to the sensor, the spirally wound copper tubing should start and end at the manifold of flanged sensor housing.
- Sudden temperature change may damage the performance of the flowmeter. Keep the temperature change of the fluid within $\pm 12^{\circ}\text{C} / \text{min}$. for both heating and cooling.

⚠ CAUTION:

1. Do not use electric heaters which could be a source of noise.
2. If ambient temperature around the transmitter is expected to exceed 55°C , separately mounted type is recommended.

6.7.1 L-Cor 8000

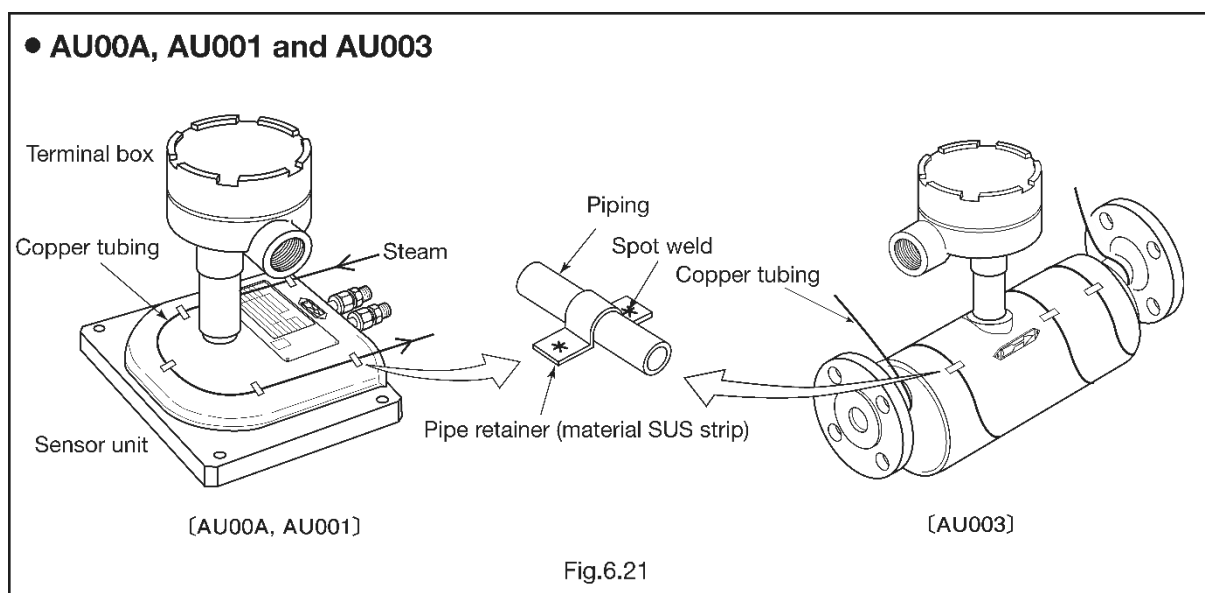

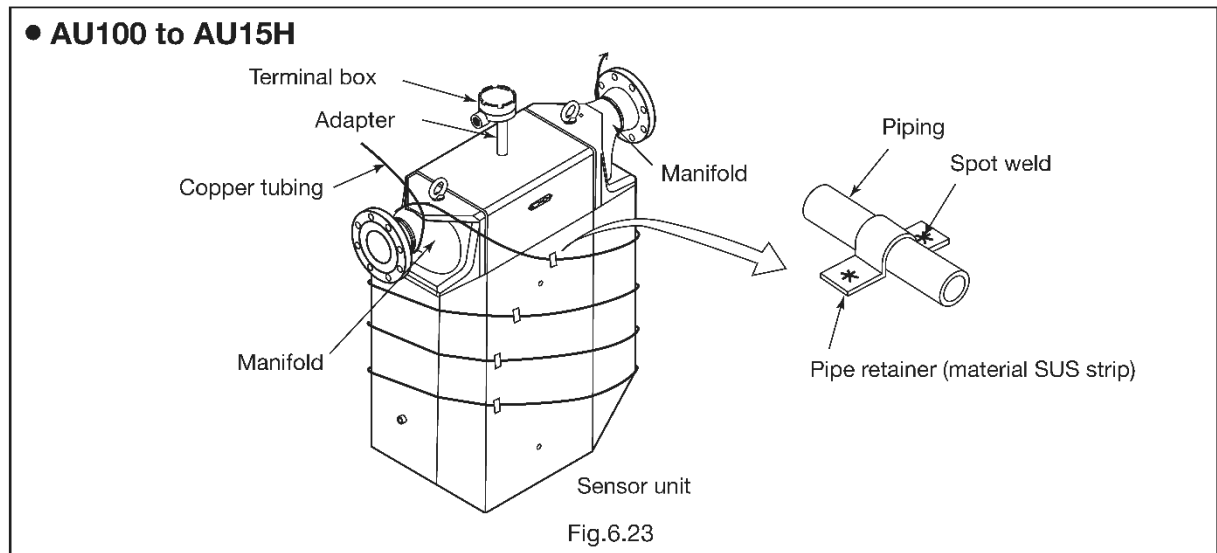
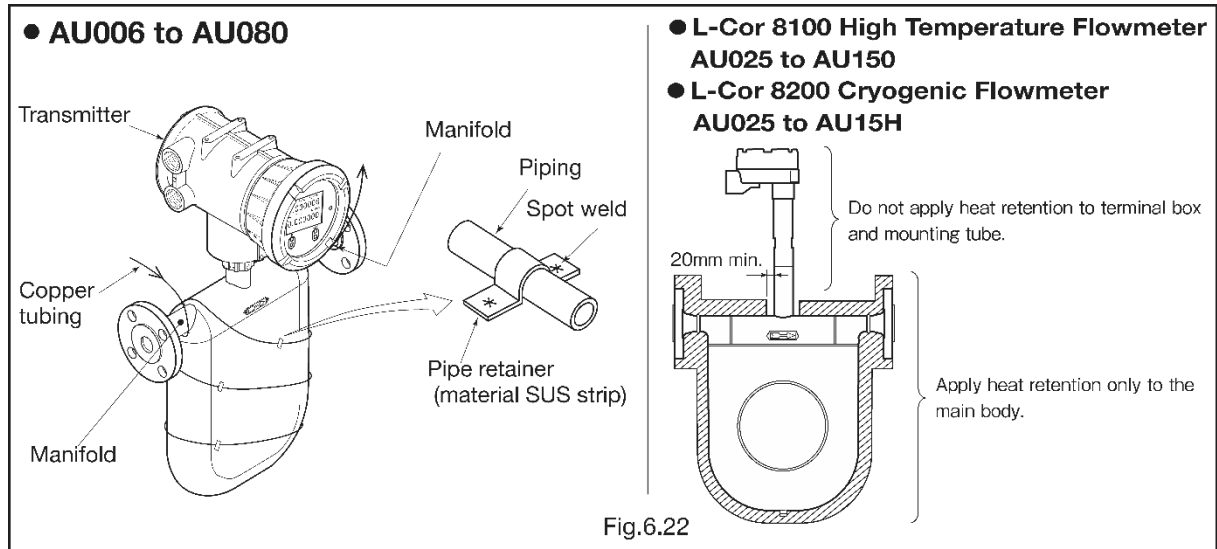

6.7.2 L-Cor 6000

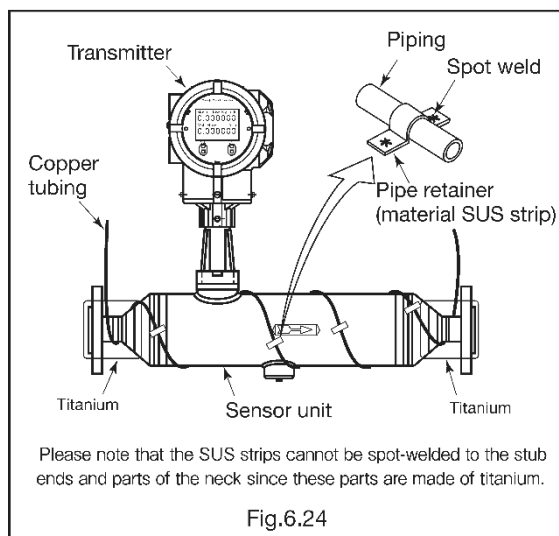

6.7.3 L-Cor 4000

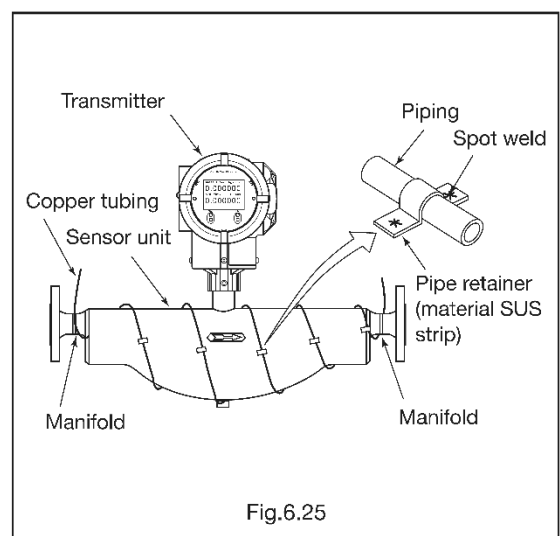

6.8 A Boss for Pressure Relief Device

L-Cor 8300 for high pressure service is provided with a pressure relief boss (Rc1/4). This pressure relief boss is installed for emergency treatment purpose for unlikely event of tube damage due to process pressure exceeding allowable tube pressure. (Fig. 6.26).

Since the permissible pressure the sensor housing can withstand is lower than that of the tube, should an emergency occur with tube rupture, the sensor housing might eventually be damaged depending on the process conditions.

Prior to shipment from the factory, a hex socket head plug (R 1/4) is threaded in the female taper pipe thread (Rc 1/4) of the boss. You may, for added security to protect the housing against damage, install a pressure switch or relief valve in the boss.

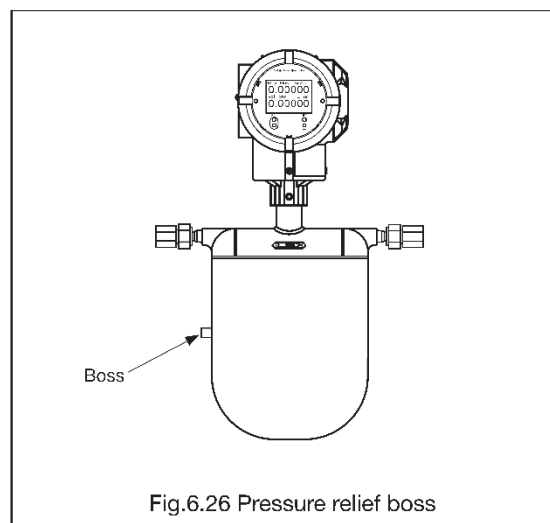

⚠ WARNING: The sensor housing unit is filled with an inert gas; do not attempt to remove the hex socket head plug unless it is absolutely necessary.

6.9 Separately Mounted Transmitter Installation

- (1) The maximum transmission cable length varies with the type of sensor unit: locate the transmitter within this range.
- (2) Secure the transmitter to a horizontal or vertical steel pipe 2 inches in nominal size using the U-bolt furnished as standard accessories.
- (3) Installation location should be accessible for maintenance and in good environment.
- (4) The customer to furnish the stanchion (steel pipe).

⚠ CAUTION: Avoid installation in such location as:

- Difficult to access for maintenance and servicing.
- Excessive temperature changes and vibration.
- Potential immersion in water.

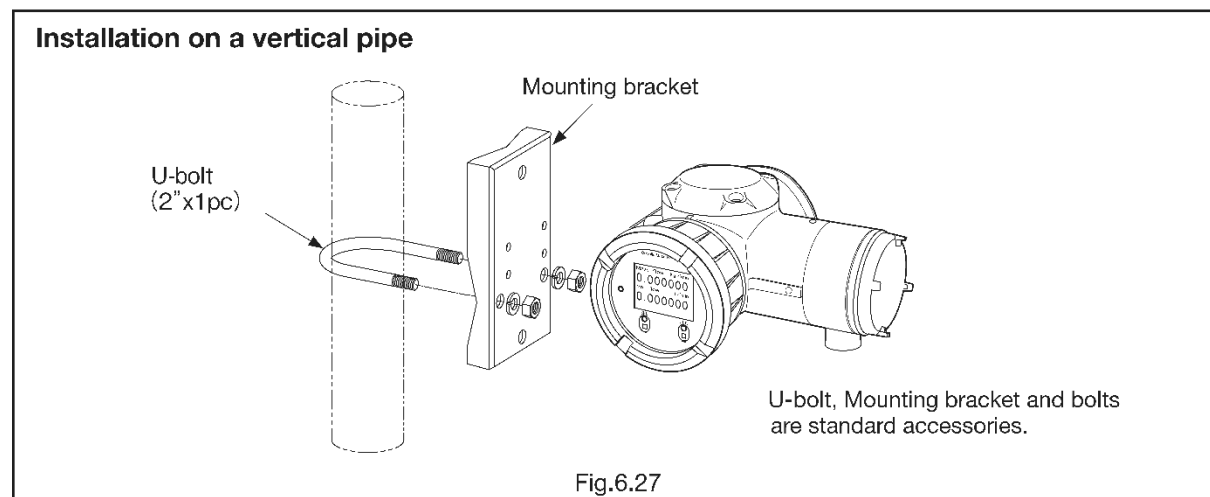

6.10 How to Change Transmitter Orientation

⚠ WARNING: Be sure to turn off power before you start working.

To change transmitter orientation, follow the steps given below:

- (1) Turn off power.
- (2) Make preparations for conduit and cable so that they will by no means cause you any trouble while changing transmitter orientation.
Work on a level plane with the transmitter up and the sensor secured so that loosening bolts will not cause the transmitter to come off.
- (3) Loosen bolts holding the transmitter adapter with hex wrench. See Fig. 4.10 (M8 hex socket head screws at four places).

⚠ WARNING: Never loosen the hex socket head screws located on the transmitter body. You may loosen bolts but never separate the transmitter from the sensor unit.

- (4) Rotate the transmitter to the desired position and secure it with setscrews (four places).

Transmitter rotatable over an arc of 180°max

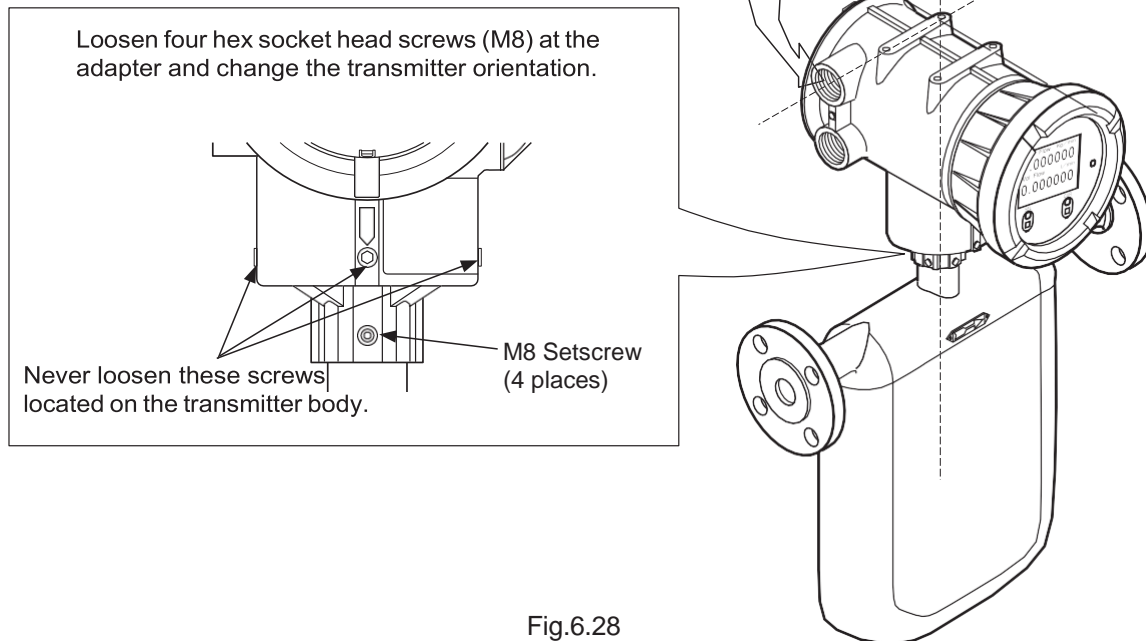

⚠ CAUTION: The transmitter may be rotated over a 180°arc as shown in Fig. 6.28. But rotating it beyond 180°will twist the harness from the sensor unit to the extent the equipment is damaged.

- (5) Confirming that the transmitter is secured in place, make conduit and wiring connections.
- (6) Verify that the flowmeter operates properly.

⚠ WARNING: With AS sensor unit, do not attempt to adjust orientation with hex socket head bolts shown in the figure below, or its functions as a flowmeter will be lost.

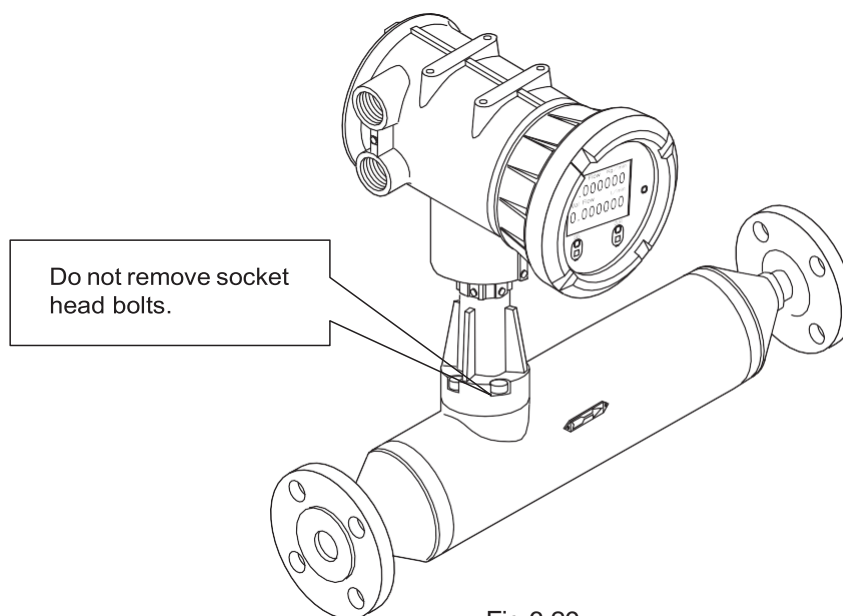
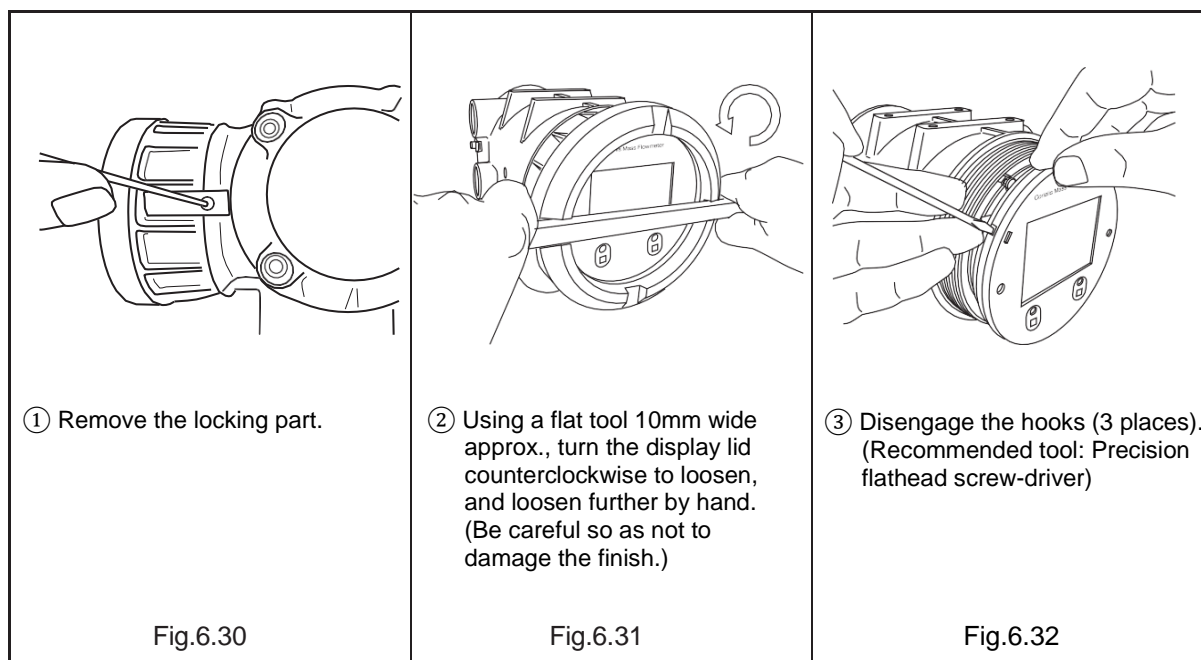

Fig.6.29

6.11 How to Change Transmitter Display Orientation

The transmitter display may be rotated through 360° in steps of 90° within the housing.

⚠ WARNING: Be sure to turn off power and discharge your static electricity before work.



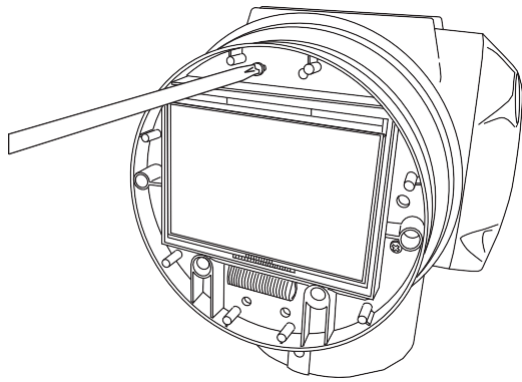

④ Loosen display unit fitting screws (3 places) with precision flathead screwdriver. "Set washers" to prevent screws from falling out are attached on the back of display; do not completely remove screws.

Fig.6.33

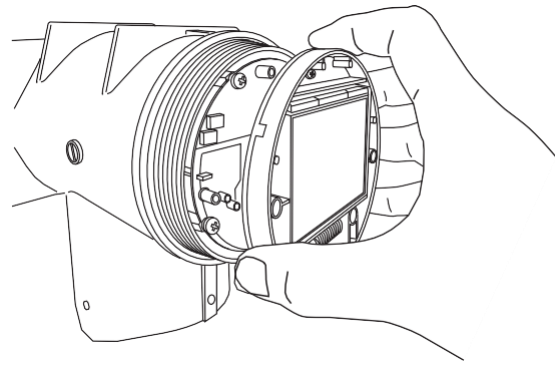

⑤ Separate the display unit.

Fig.6.34

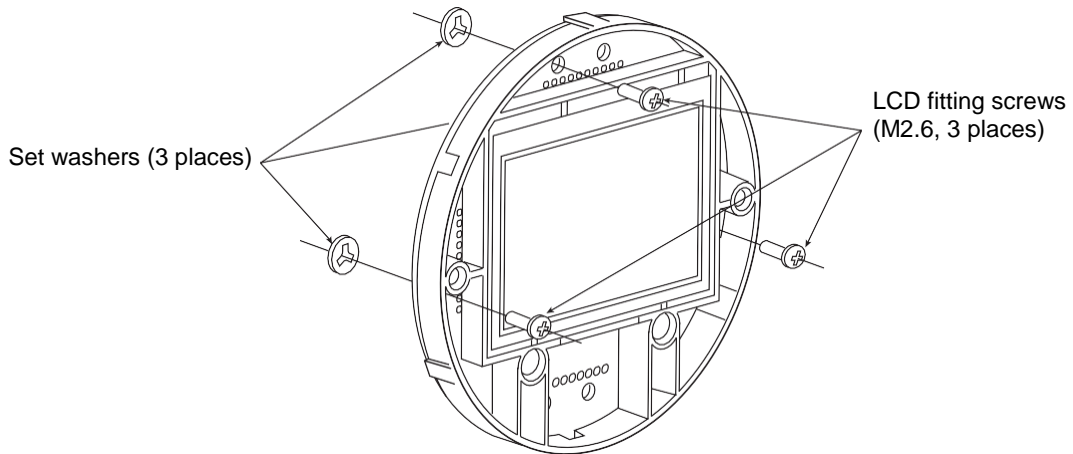

Fig.6.35

⑥ For the display unit that has just been removed, it is necessary to take off fitting screws once, adjust the orientation and re-install them. Shown below are the location of screw holes for different orientations.

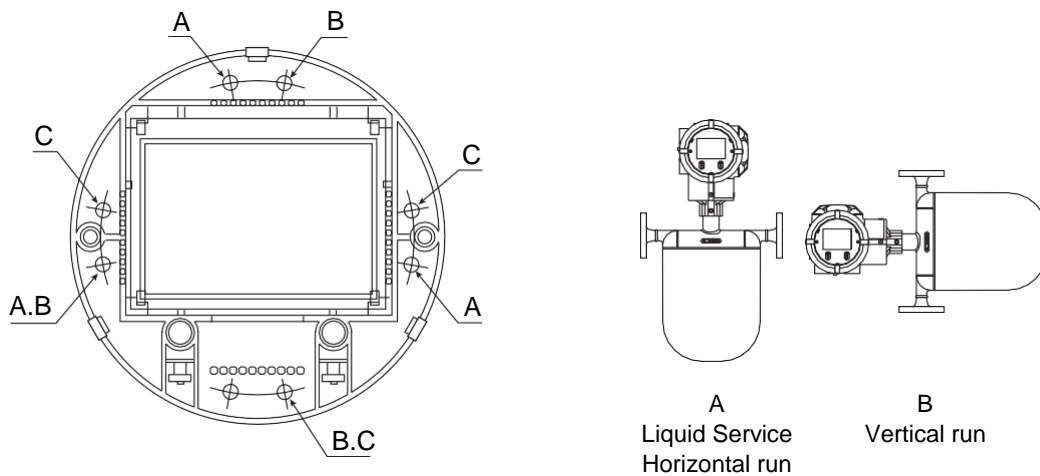
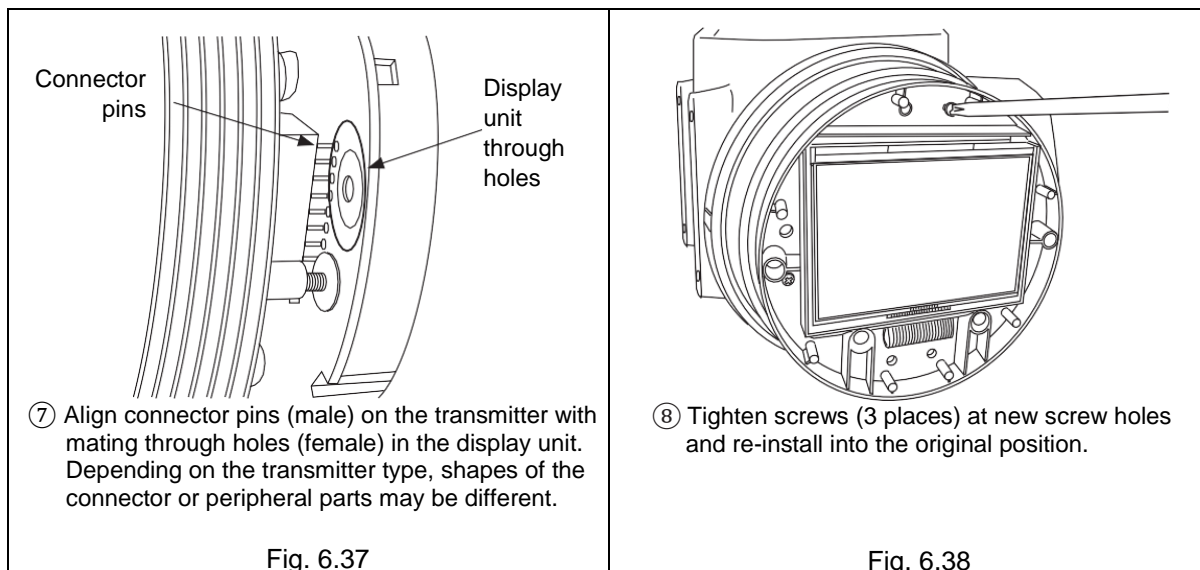

Fig.6.36



⚠ CAUTION: When tightening the display lid, tighten securely using a flat tool or similar instrument. Insufficient tightening can affect gas tightness and sensitivity of display's optical switch.

7 Wiring Instructions

7.1 Wiring Connections

7.1.1 Power and output signal connections (both integrally and separately mounted models)

Terminals for wiring connections with the sensor unit are found on the side of transmitter housing. Remove the cover and make wiring connections.

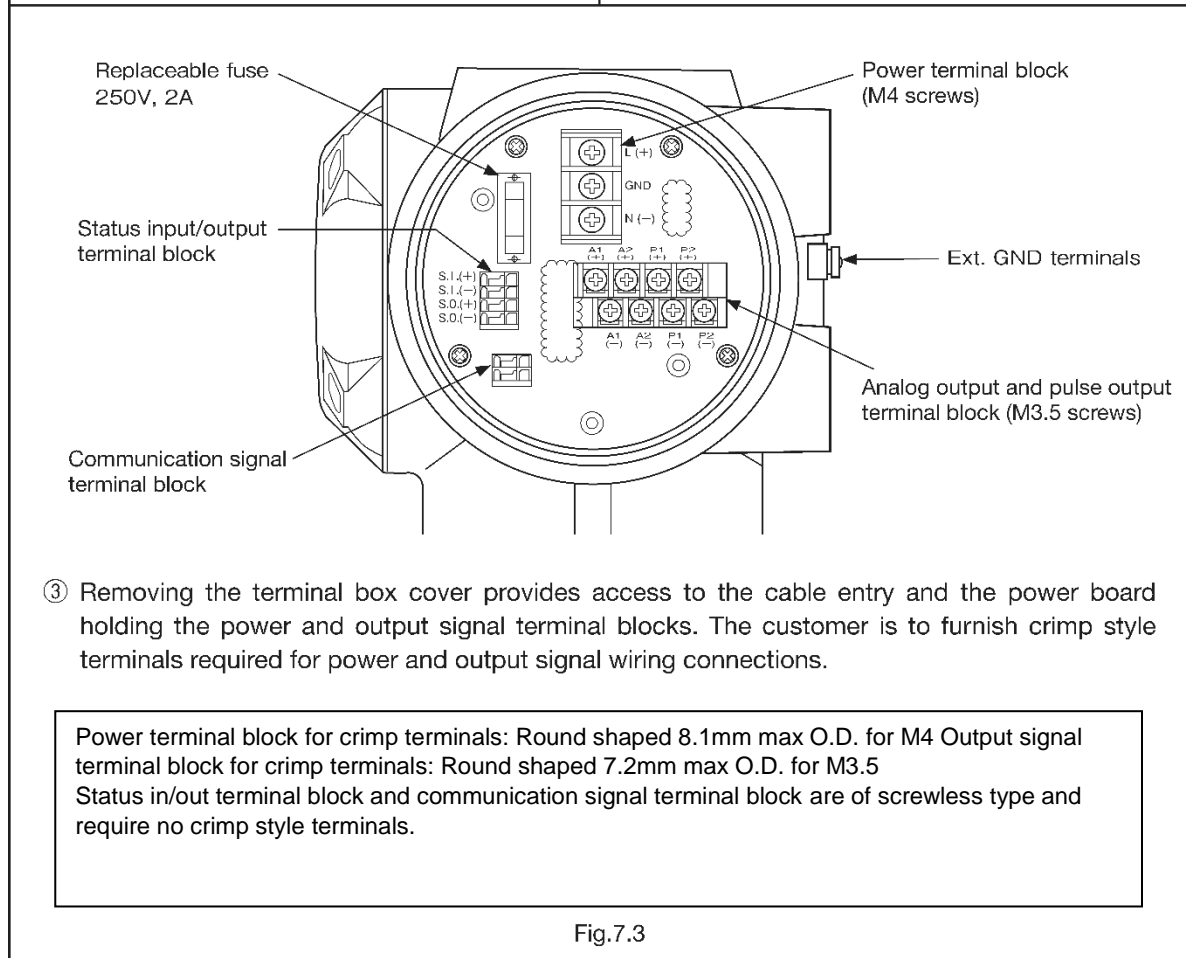
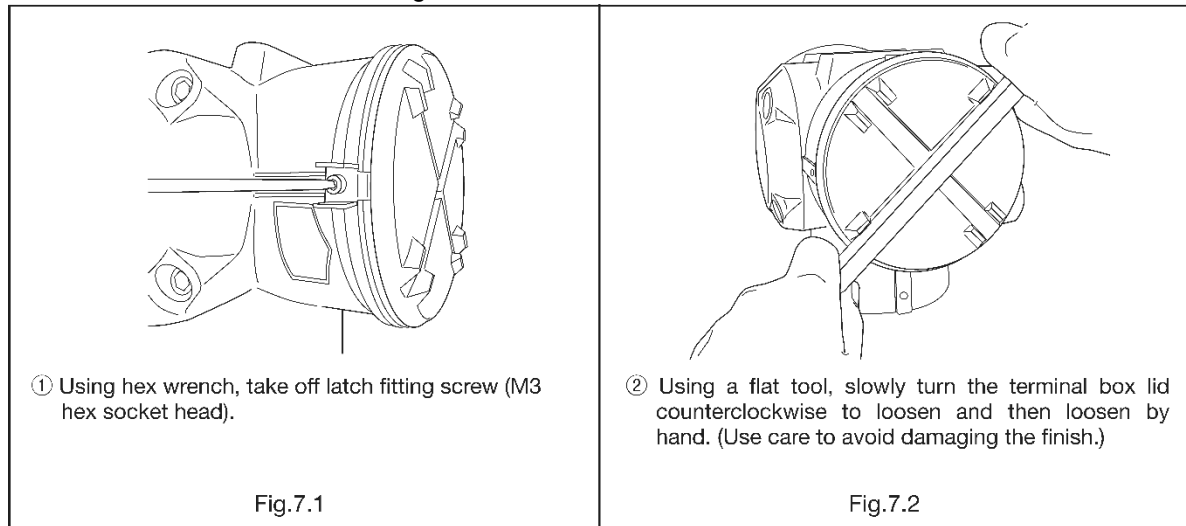

7.1.2 Connections between separately mounted sensor unit and transmitter

Terminals for wiring connections with the sensor unit are found on the side of transmitter housing. Remove the cover and make wiring connections.

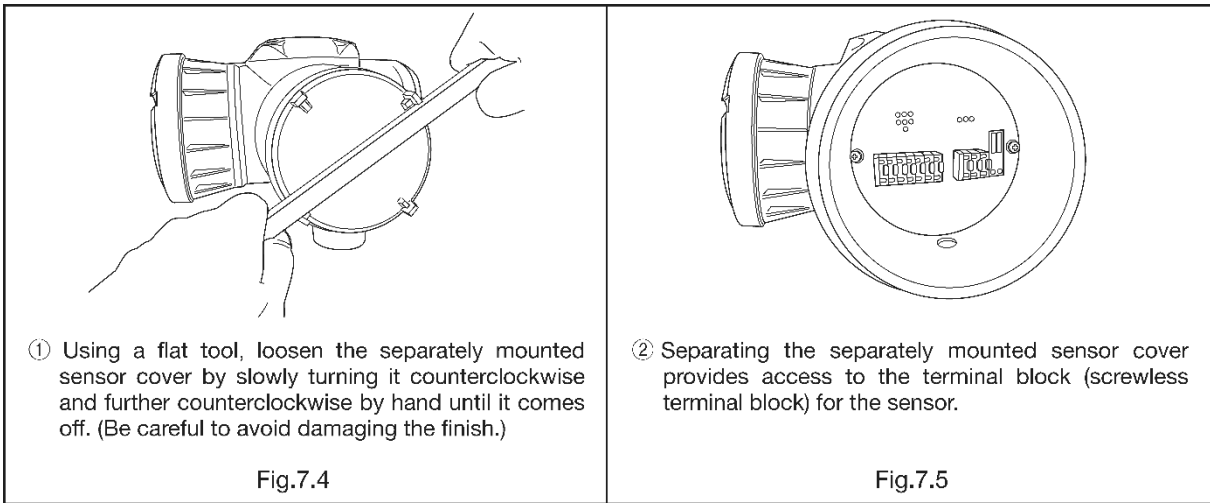

NOTE: About jumper on sensor terminal block in Fig. 7.5

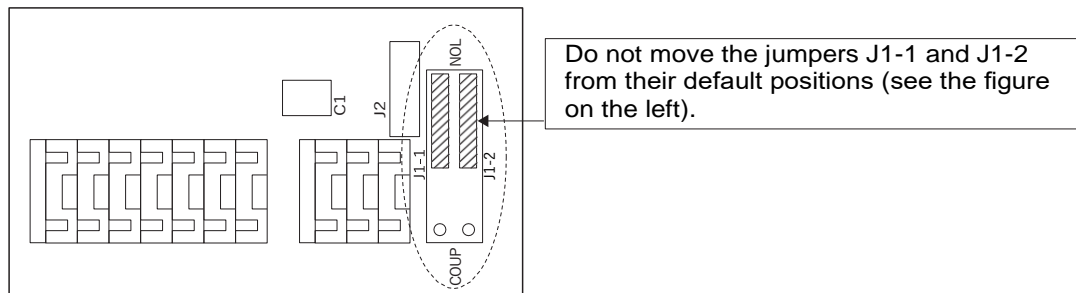

7.2 Power Supply Lines and Ground Terminal

- (1) Power source primary lines are connected to terminals L (+) and N (-).
(Overvoltage Category II, Pollution Degree 2.)
- (2) Connection to earth ground terminal: Connect only to GND on the power terminal block or external ground terminal.

⚠ CAUTION: Supply voltage must be within the range shown in the product nameplate attached to the housing.

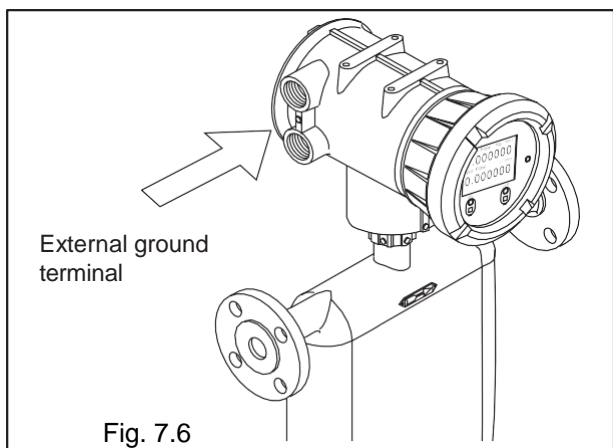

7.3 Analog Output Wiring

When analog output (4 to 20mA) is to be connected to a receiving instrument, Analog Output 1 has terminals A1 (+) and terminal A1 (-) while Analog Output 2 has terminal A2 (+) and terminal A2 (-). Maximum load resistance is 600Ω. Analog output setup procedure appears in 9.7.1 Analog output functions.

* Analog output will be invalid if Fieldbus, PROFIBUS PA is selected as communication interface.

7.4 Pulse Output Wiring

When pulse output is to be connected to a receiving instrument, Pulse Output 1 has terminals P1 (+) and terminal P1 (-) while Pulse Output 2 has terminal P2 (+) and terminal P2 (-).

If voltage pulse signal is your option, signal transmission length has restrictions on output frequency.

Output frequency	Max transmission length*
10kHz	10m
1kHz	100m
100Hz	1000m

* Values are based on wire material 0.75 sq in cross section.

To change from voltage pulse output to open drain pulse output, or vice versa, remove the front lid and select jumper positions as indicated below.

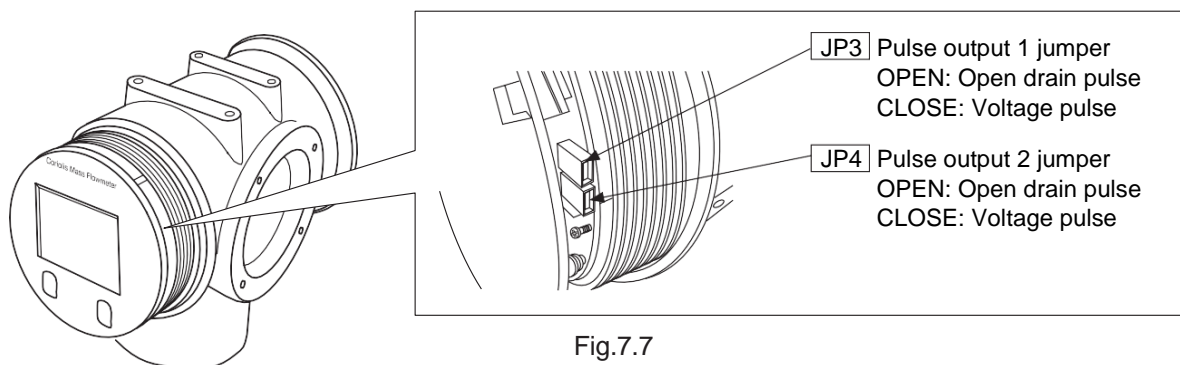

Fig.7.7

Pulse output setup procedure appears in 9.7.2 Analog output.

* Pulse output will be invalid if Fieldbus, PROFIBUS PA is selected as communication interface.

⚠ CAUTION: JP2 and JP5 exist on the same board as JP3 and JP4. Do NOT remove or change the positions of JP2 and JP5. The transmitter may not work properly.

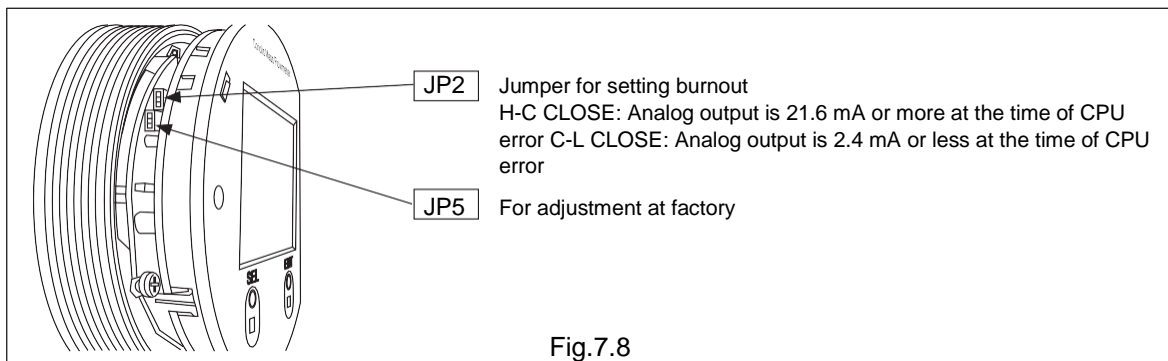

Fig.7.8

7.5 Status Output Wiring

Status output appears across terminals S.O. (+) and S.O. (-).

Status output setup procedure appears in 9.7.3 Status output.

* Status output will be invalid if Fieldbus, PROFIBUS PA is selected as communication interface.

7.6 Status Input Wiring

Status input appears across terminals S.I. (+) and S.I. (-).
Status input setup procedure appears in 9.7.4 Status input.

*Status input will be invalid if Fieldbus, PROFIBUS PA is selected as communication interface.

7.7 Communication Line Wiring (Option)

For communications (option), use terminals I/O. (+) and I/O. (-).

⚠ CAUTION: 1. Bell 202 communications protocol does not use these terminals. It uses analog output 1 terminal.
2. Other communication interfaces require different handling. Please refer to the supplementary communication manuals.

Fieldbus communication:

"L-Cor series communication manual for Fieldbus"

PROFIBUS PA communication:

"L-Cor series communication manual for PROFIBUS PA"

Modbus communication:

"L-Cor series communication manual for Modbus"

7.8 Recommended Cables Condition

Item	Label	Recommended condition			
		Rating voltage/ allowable current (at 30°C)	Cross-section	Solderless terminals	Maximum operating temp.
Power	L (+)	300V over, 2A over	1.25sq to 2.0sq AWG14 to 16	R-type, 8.1mm less Size: M4	60°C over *2
	N (-)				
	GND				
Signal	A1 (+)	100V over, 0.1A over	0.75sq to 2.0sq AWG14 to 18 *1	R-type, 7.2mm less Size: M3.5	
	A1 (-)				
	A2 (+)				
	A2 (-)				
	P1 (+)				
	P1 (-)				
	P2 (+)				
	P2 (-)				
	S.I. (+)			Need no Screwless terminal type	
	S.I. (-)				
	S.O. (+)				
S.O. (-)					
Communication	I/O (+)	0.75sq AWG18			
	I/O (-)				
External ground		600V over, 40A over	4sq over AWG12 over	Directly wiring or Solderless terminal (R-type, 8.1mm less)	

NOTE:

- * Please select the cable size to be used with the number of signals.
- * Depending on the number of output signals used, selection for the right cable material must be made referring to the table on the next page.

Recommended cable condition for Fieldbus and PROFIBUS communication

Cable specification	Size	Max cable length	Impedance	Specific resistance	Attenuation	Association-recommended	Anton Paar recommended
Type A Twisted pair cable (pair shielded)	18AWG 0.8mm ²	1900m	100Ω	22Ω/km	3dB/km	○	○
Type B Twisted pair cable (common shielded)	22AWG 0.32mm ²	1200m	100Ω	56Ω/km	5dB/km	○	
Type C Twisted pair cable (unshielded)	26AWG 0.13mm ²	400m	no regulation	132Ω/km	8dB/km	○	
Type D Straight through cable (common shielded)	16AWG 1.25mm ²	200m	no regulation	20Ω/km	8dB/km	○	○

Source: IEC 61158-2 : "Digital data communications for measurement and control – Fieldbus for use industrial control systems – Part 2: Physical layer specification and service definition"

NOTE:

Placeable cable lengths vary depending on actual field conditions. For the details, refer to the documents listed below:

- * "PROFIBUS PA Technology and Application"
- * Fieldbus Application Guide AG-140; "Wiring and Installation; 31.25 kbit/s, Voltage; Model, Wire Medium"

Recommended cable condition for Modbus communication

Cable specification	Size	Max cable length
Twisted pair	0.75mm ²	1200m (depends on operation environment)

Applicable rubber packing size for wire lines and sizes

Cable packing gum ID.	Recommended wire size				Remarks
	2sq	1.25sq	0.9sq	0.75sq	
φ 8.1 to φ 9.0	2	2	2	2	Fieldbus, PROFIBUS PA Communication cable
φ 9.1 to φ 10.0	2	2	2	2	
φ 10.1 to φ 11.0	2	3, 4	6, 7	6, 7	
φ 11.1 to φ 12.0	3, 4	5	8	8	
φ 12.1 to φ 13.0	5	6	10, 12	10, 12	
φ 13.1 to φ 14.0	6	7, 8	-	-	

NOTE: Use shielded cables.

7.9 Terminal Identification of Separately Mounted Transmitter

Item	Terminal name	Terminal No.	Terminal color	Description
Sensor unit to transmitter interconnect cable (200 meters max) *	TB20	1AB	BRN	Flow tube drive output
		2AB	RED	
		3AB	BLK	BRN/RED, GRN/WHT, BLU/GRY, PUR/ORG/YEL shielded wires bundled
	TB21	1AB	PUR	Temperature input (inner)
		2AB	ORG	Temperature input (outer)
		3AB	YEL	Temperature input
		4AB	BLU	Right position pickoff sensor input
		5AB	GRY	
		6AB	WHT	Left position pickoff sensor input
		7AB	GRN	

NOTE:

* The length of L-Cor 8000 AU00A/AU001 is max 100m, the length of L-Cor 6000 titanium tube type is max 100m, and the length of L-Cor 4000 is max 50m.

7.10 Wiring Diagram

7.10.1 Transmitter power and output signal wiring

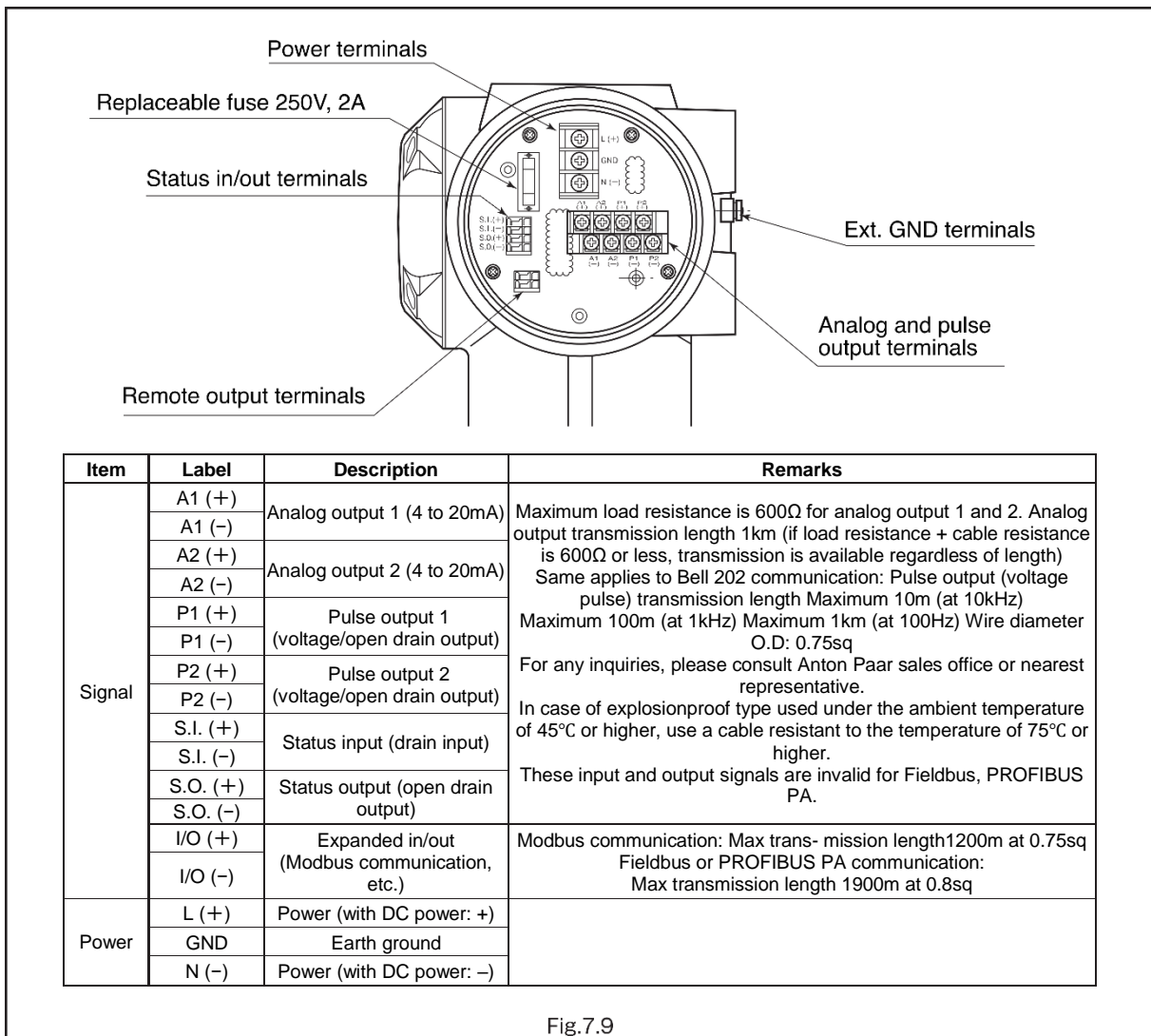
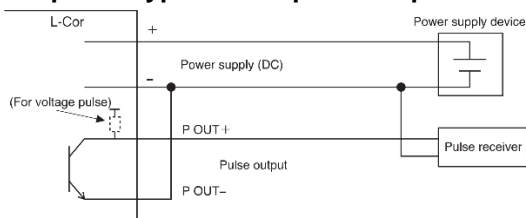

Fig.7.9

Conduct earth grounding work at external ground terminal or "GND" on the power terminal block (Grade D grounding work).

⚠ CAUTION: In case supplying electric power to this flowmeter, do not fail to connect a protective fuse of rated voltage 2A max

DC power type: 3-wire pulse output connection



* If using the cable in long-distance, the LO level power supply of pulse signal will increase due to stationary current of the transmitter and line resistance of the cable. Adjust the trigger value of the receiver properly.
For example:
If the cable length is 500m, LO level increases approx., 2.5V (given 1.25sq: 16Ω/km)

Connecting diagram

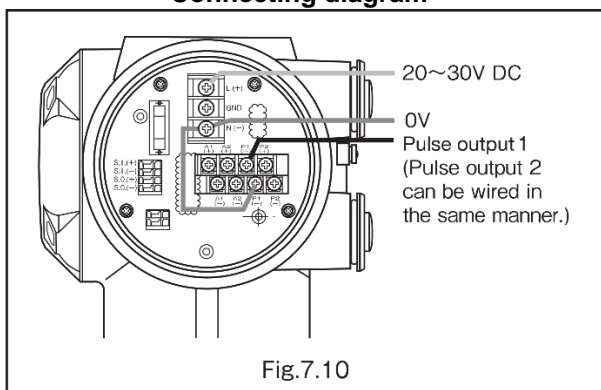

Fig.7.10

7.10.2 Separately mounted sensor unit and transmitter wiring

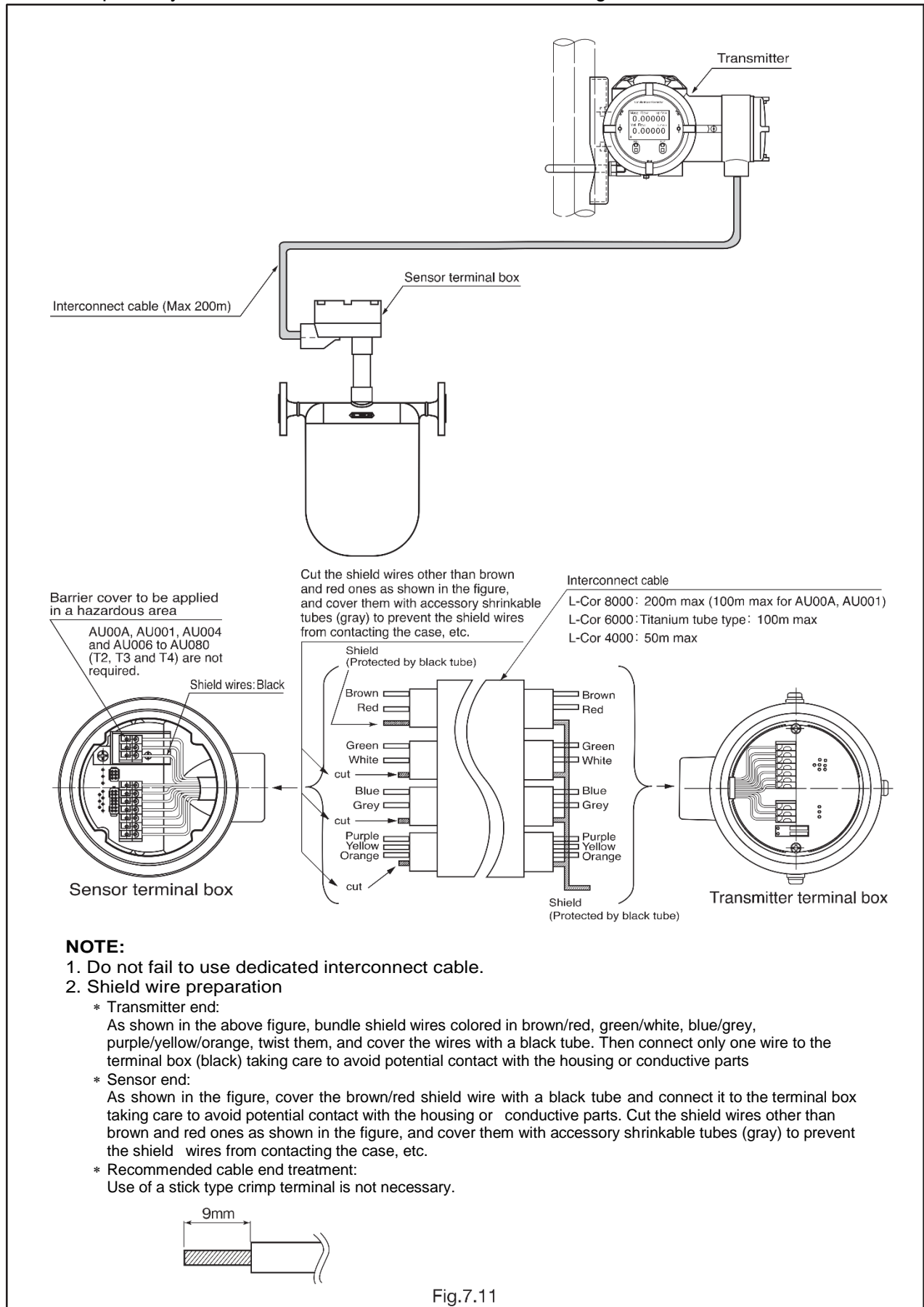

Fig.7.11

7.11 How to Change Cable Entry Orientation of Terminal Box (Separately Mounted Type)

Of the sensor unit, the orientation of the terminal box's cable entry can be changed.

NOTE: Although the terminal box can be rotated by loosening four hex-socket head screws at the adapter, the following procedure must be followed.

⚠ CAUTION: Rotating the terminal box without following the procedure will cause sensor damage.

Procedure

- ① Turn OFF flowmeter power.
- ② Using a flat tool, slowly loosen the terminal box lid by turning counterclockwise, and loosen further by hand.
(Be careful not to damage the finish.)
(Fig.7.12)

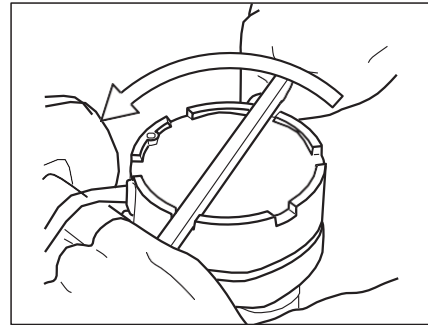

Fig. 7.12

Inside, the structure of terminal block can be either A or B shown below. Follow procedure ③~⑤ according to the type of your terminal block.

	Terminal block A	Terminal block B
③ Remove the isolation cover. (Fig.7.13, Fig.7.14)	<p>Fig.7.13</p>	<p>Fig.7.14</p>
④ Disconnect the cables from the terminal block. (Fig.7.15, Fig.7.16)	<p>Fig.7.15</p>	<p>Fig.7.16</p>
	Terminal block A	Terminal block B

- ⑤ Remove screws from terminal block. (3 places for A, 2 places for B)

* Make sure not to drop or lose screws.
(Fig.7.17, Fig.7.18)

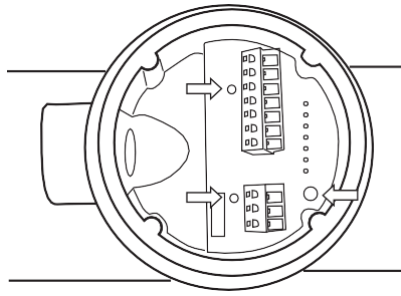

Fig.7.17

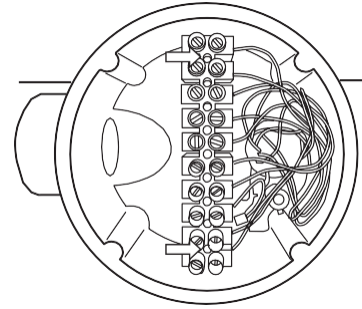

Fig.7.18

- ⑥ Remove caution label (sticker) and loosen hex-socket head screws (4 places). (Fig.7.19, Fig.7.20)
- ⑦ Rotate terminal box without exerting excessive force onto sensor cables.
- ⑧ After rotating, reassemble terminal box in reverse procedure.

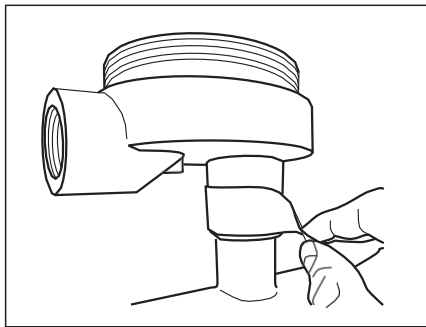

Fig. 7.19

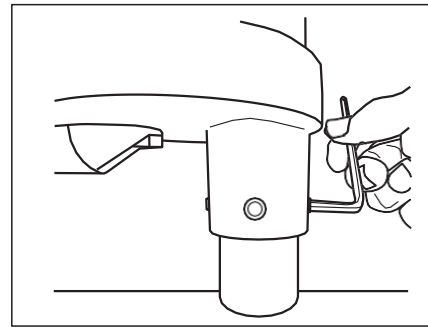

Fig. 7.20

8 Operation

8.1 Flushing the Piping Assembly

If scale and sludge are expected to be left in the piping assembly, particularly in a new piping assembly, flush the assembly prior to sensor unit installation.

8.2 Confirming the Sensor Unit for Correct Installation

For safety reasons, check the tightness of connection bolt, condition of gasket and the flow direction.

8.3 Leak Check

Fill the sensor tube completely with process fluid and check for any leak from connections.

8.4 Supplying the Power

Upon completion of checks for correct wiring connections, supply power. The LCD will show the following information:

Self-Diag	OK
Temp Connect	OK
P.O. Connect	OK
Drive Coil	OK
EEPROM	OK
Data Update	OK
Txr Temp	OK

Self-diagnostics begins.

If nothing unusual is found, "OK" appears at right of each item, bringing up the next window.

(If NG appears, running a check on that item is required.

See 9.6.3 Transmitter Check, correct the condition, and turn on power again.)

↓

Mass Flow	g/s
0 . 0 0 0 0	
Vol Flow	L/min
0 . 0 0 0 0	
↓	WARM UP 20

Variable view and measurement begins.

8.5 Measurement Line Startup

By starting up the pump, opening valves, etc., carefully allow the process fluid to flow.

8.6 Warm-up

To ensure stability of the measuring conditions of equipment, provide about 20 minutes, warmup period. (A message "WARMUP 20" stays on after startup. The number shows remaining time (min).)

8.7 Zeroing Procedure

On seeing that the measuring conditions have come to an equilibrium, shut off the downstream valve completely. Make a zeroing adjustment under these conditions (see the topic under 9.8 Zeroing).

8.8 Ready for Operation

Now preparation for operation is complete. Initiate measurement.

9 Description of Incorporated Functions

9.1 Display

9.1.1 Description of display

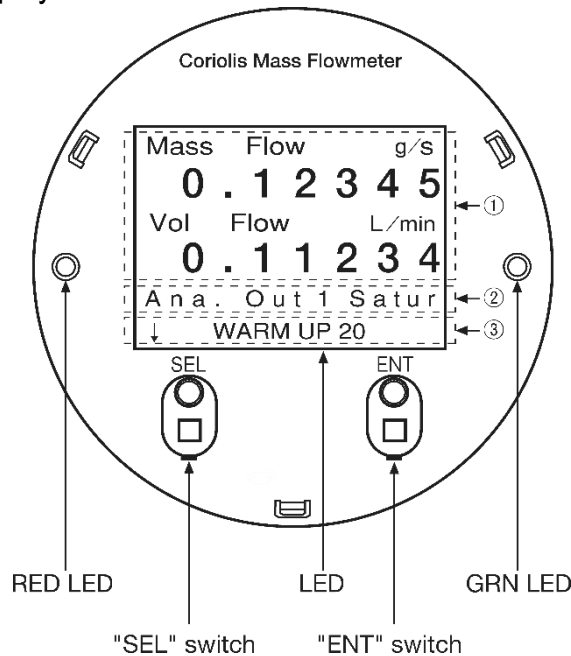

(1) LCD top row (①)

Shows measurements. Other variables also can be shown with switches. (An example at above shows instant mass flowrate and instant volume flowrate. For details of displayed variables, see 9.1.3 View variables.)

(2) LCD middle row (②)

Shows an error / status message.

For error messages, see 10.1 Error Messages and 10.2 Status Messages. If more than two messages exist, they are shown one after another.

(3) LCD bottom row (③)

In the view variables screen, an arrow appears, pointing to the direction of scroll. By reversing the arrow direction, you can reverse the direction of scroll. (For details, see 9.1.3 View variables.)

A black circle ● may blink on and off at right of arrow. (It indicates that the number of running hours has exceeded 100,000. For necessary treatment, see 10.2 Status Messages.)

(4) Red LED and green LED

Similar to messages, these LED show the status of flowmeter. In normal operation, red LED stays off; green LED stays on.

Anything else is indicative of occurrence of something erratic. See 10.1 Error Messages and 10.2 Status Messages.

(5) "SEL" and "ENT" switches

An infrared switch. Responds to a finger held close to it. For operating procedure, see 9.1.2 Switch operation.

NOTE: If the infrared sensors do not respond sufficiently, use L-Cor software to adjust the sensitivity. In case you do not have L-Cor software, use a reflecting subject, such as a sheet of paper, to operate the switches.

9.1.2 Switch operation

The transmitter has two infrared switches: "SEL" and "ENT". Operation of these switches is described here. For information about parameter configuration and other functions, see the respective sections.

(1) "ENT" operation

This switch is used for scrolling the display, scrolling the cursor, etc. Here we cover "ENT" operation as an example of switching variables view screens.

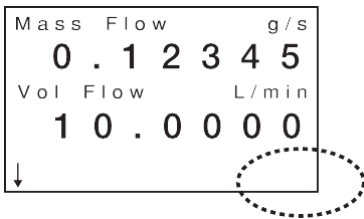

① Touch ENT key at lower right of screen over glass faceplate with your finger. When the key responds, a down arrow ▼ appears at lower right of screen (surrounded by a dotted circle) where nothing was found as shown in the next screen.

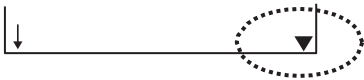

② After down arrow comes on for 0.5 sec, arrow ▼ is highlighted as shown in the following screen.

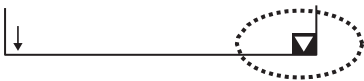

③ While the highlighted arrow stays on (0.5s), remove your finger. Arrow ▼ goes out and the screen changes. (With your finger held on, you can continue "ENT" operation. It is beneficial for fast scroll.)

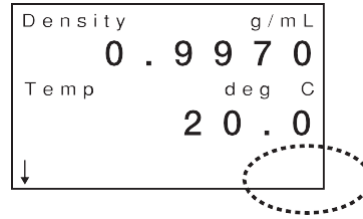

④ End of "ENT" operation. The next screen appears.

(2) "SEL" operation

This operation is used to switch screen direction, increasing the number, parameter select, etc. Here we cover "SEL1" operation as an example of switching screen direction.

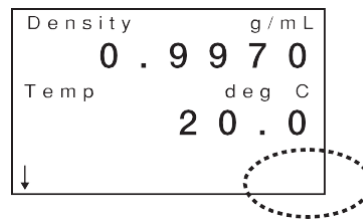

① Touch SEL key at lower left of screen over glass faceplate with your finger. When the key responds, a letter S appears at right bottom of screen (surrounded by a dotted circle) where nothing was found as shown in the next screen.



② After letter S comes on for 0.5 sec, the letter S appears highlighted as shown in the following screen.



③ While the highlighted S stays on (0.5s), remove your finger. Letter S goes out and arrow ↓ at bottom left of screen changes to ↑. (With your finger held on, you can continue "SEL" operation. It is beneficial for quickly increasing the number.)

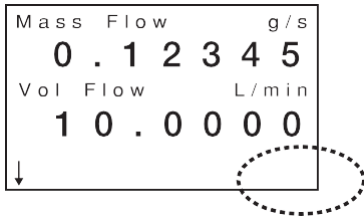

④ End of "SEL" operation Arrow ↓ has changed to ↑. Operating "ENT" in this state allows the screen to scroll in the opposite direction.

(3) "SEL3" operation

This operation is used to finalize the numeric value that has been changed and activate it, etc. Here we cover "SEL3" operation as an example of switching to MODE SELECT menu screen.



① Touch SEL key at lower left of screen over glass faceplate with your finger. When the key responds, a letter S appears in the highlighted S3 area at lower right of screen. (On certain screens, letter S3 may appear at lower center of screen.)

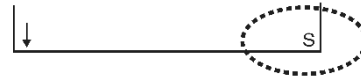

② Hold your finger on. After letter S comes on for 0.5 sec, the letter S appears highlighted as shown in the following screen.

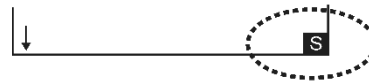

③ While holding your finger on, the screen repeats a change between highlighted and not highlighted. On the third appearance of highlighted S (duration 0.5 sec), remove your finger. A switch to MODE SELECT menu screen takes place.



④ End of "SEL3" operation A switch to MODE SELECT menu screen is complete.

9.1.3 View the variables

(1) Description of displayed information

The following description illustrates the display image with the AU sensor (default settings). Please refer to the description on the right for each display content.

You can change the display by operating the switch. Perform the switch operation to show the desired item.

<p>Click "ENT", (*1 with ↓) Click "ENT", (*1 with ↑)</p>	<ul style="list-style-type: none"> ● Mass Flow: Represents the instantaneous mass flow rate. <ul style="list-style-type: none"> • The decimal point position can be changed based on the settings. (Refer to Transition Chart (1) [No. 1-3-4-1] in section 9.2.2. for detail.) • The unit can be changed based on the settings. (Refer to Transition Chart (2) [No. 2-1-1] in section 9.2.3. for detail.) ● Vol Flow or Vol Flow(s): Represents the instantaneous volume flow rate. <ul style="list-style-type: none"> • The decimal point position can be changed based on the settings. (Refer to Transition Chart (1) [No. 1-3-4-2] in section 9.2.2. for detail.) • The unit can be changed based on the settings. (Refer to Transition Chart (2) [No. 2-1-2] in section 9.2.3. for detail.) • If the fixed density option is selected, it will be displayed as Vol Flow(s). • When the density is below 0.3 g/ml, the volume flow rate becomes 0.
<p>Click "ENT", (*1 with ↓) Click "ENT", (*1 with ↑)</p>	<ul style="list-style-type: none"> ● Density: Represents the fluid density. <ul style="list-style-type: none"> • The decimal point position can be changed based on the settings. (Refer to Transition Chart (1) [No. 1-3-4-3] in section 9.2.2. for detail.) • The unit can be changed based on the settings. (Refer to Transition Chart (2) [No. 2-2-1] in section 9.2.3. for detail.) ● Temp: Represents the fluid temperature. <ul style="list-style-type: none"> • The unit can be changed based on the settings. (Refer to Transition Chart (2) [No. 2-3-1] in section 9.2.2. for detail.)
<p>Click "ENT", (*1 with ↓) Click "ENT", (*1 with ↑)</p>	<ul style="list-style-type: none"> ● Counter 1: Represents the count of pulse output 1. <ul style="list-style-type: none"> • When the reading exceeds "99999999," it resets to 0. • The value is retained even when the power is turned off. • It can be reset to 0 using the Count/Total 1 Reset function. (Refer to Transition Chart (6) [No.3-5-1] in section 9.2.7. for detail.) • Modifying parameters related to pulse output 1 will reset it to 0. ● Counter 2: Represents the count of pulse output 2. <ul style="list-style-type: none"> • When the reading exceeds "99999999," it resets to 0. • The value is retained even when the power is turned off. • It can be reset to 0 using the Count/Total 2 Reset function. (Refer to Transition Chart (6) [No.3-5-2] in section 9.2.7. for detail.) • Modifying parameters related to pulse output 2 will reset it to 0.

*1: By using the "SEL1" operation, you can change the scroll direction by reversing the orientation of the arrow at the lower left. (Refer to the "SEL1" operation in section 9.1.2 for switch operation details.)

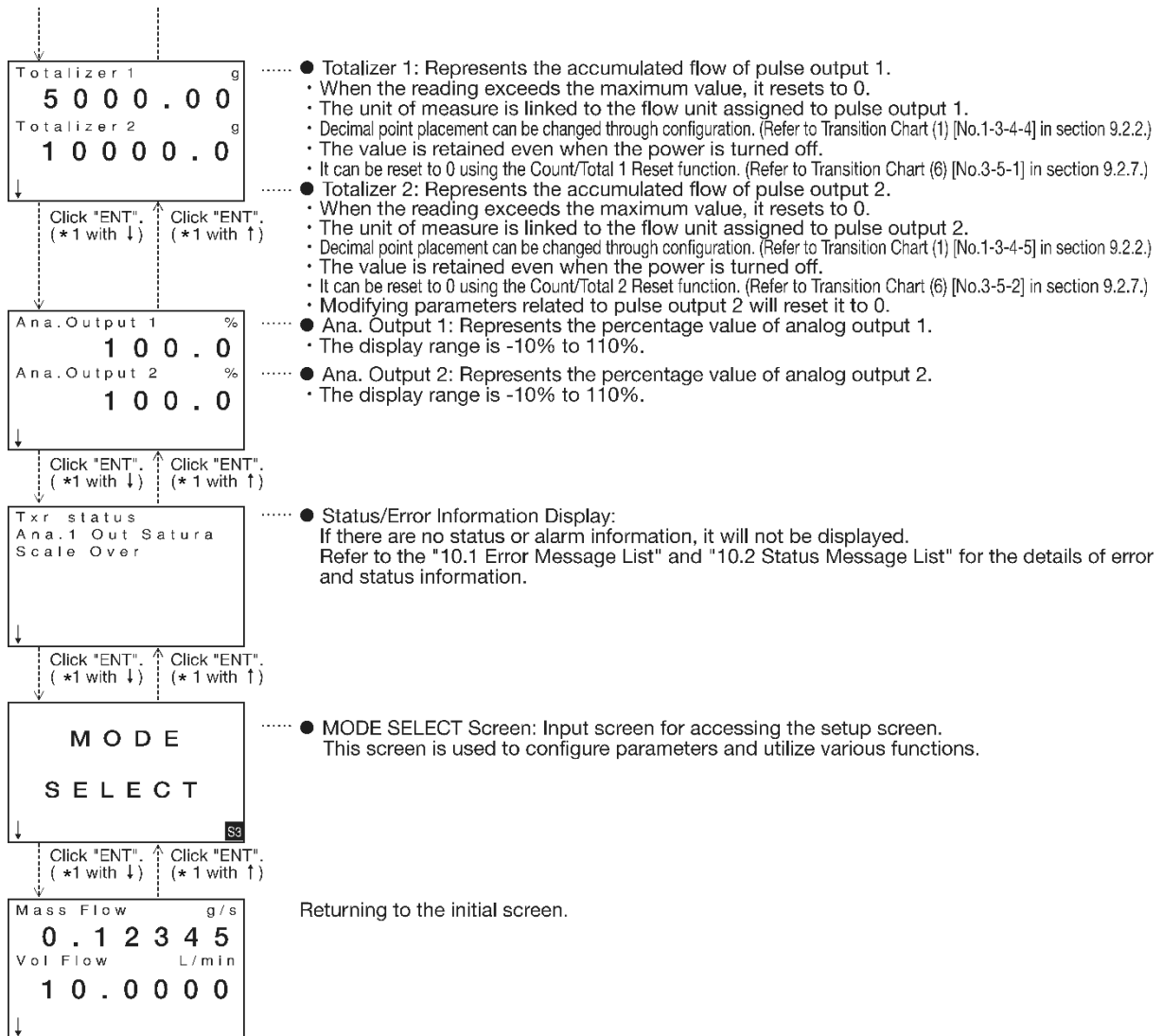

*1: By using the "SEL1" operation, you can change the scroll direction by reversing the orientation of the arrow at the lower left. (Refer to the "SEL1" operation in section 9.1.2 for switch operation details.)

(2) To change the style of view variables:

- Display/hide of individual items and their priority can be changed. (For details, see 9.11 Variables view screen setup.)
- Display font size can be changed. In default setting, alphanumeric is displayed in large fonts; two items appear in one screen. By selecting the standard font, it is possible to indicate 3 items in one screen. (For details, see 9.2.2 Transition chart (1) [No. 1-3-3].)

9.2 View Parameters and Description

Numerous parameters and functions are incorporated in this transmitter. In 9.2.1 Setup menu window, procedures to bring up MODE SELECT menu screen, the initial screen to show menu items, are covered. For explanation of individual parameters, see 9.2.2 Transition chart.

9.2.1 View the setup menu

To reconfigure parameters, etc., it is necessary to bring up the MODE SELECT menu screen at first. The following is the procedure:

 **CAUTION: Notes on Write Protect mode**

Write protect mode is a factory present mode which restricts parameter changes or executing functions related to measurement accuracy, performance, and measurement values of this device to prevent posing problems in case the device is used for custody transfer, etc.

If the target parameter is changed or the function is executed when the device is set to Write Protect mode, the message "Write protect" ("Write protected" on L-Cor software) is displayed on the LCD screen or screen of communication terminal such as L-Cor software and the operation is not accepted. For the target parameters of Write Protect mode, refer to the note "1" shown in sections 9.2.2 to 9.2.7.**

Write Protect mode cannot be set or cancelled by customer. If setting/cancelling of this mode is required, please contact the distributor you purchased the product.



(1) Bringing up "MODE SELECT" screen
 Repeat "ENT" operation until "MODE SELECT" screen appears.
 (For detail of operation, see 9.1.2 Switch operation.)
 Shown at left is the "MODE SELECT" screen.

Operate "SEL3".

(2) Operation on menu view
 Click "SEL3". A switch to "MODE SELECT menu" screen takes place.
 (If password is enabled, a password setup screen appears.)
 (See 9.5 Password Function which will guide you the rest of the way.)

★ Password is not set.

★ Password is set.

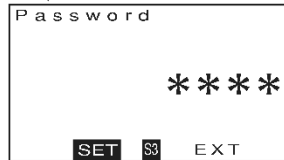

Password setup screen
 For the rest of the way, see 9.5 Password Functions.



3) "MODE SELECT" menu screen appears.
 From this screen, you are ready to configure parameters and to run various functions.
 For view parameters and description, see the respective item in 9.2.2 to 9.2.7 Transition charts.

Operate "ENT" 4 times.

To return to the normal screen without proceeding to setup process, operate "ENT" 4 times and select Exit.
 Then, operate "SEL1" to return to the normal screen.

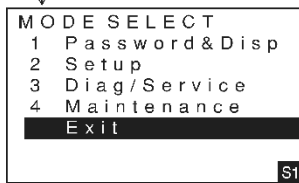

Operate "SEL1".

(4) Normal screen appears.

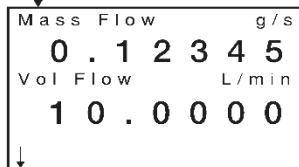

⚠ CAUTION: If no command arrives within 5 minutes at "Mode Select" menu screen, it returns to the normal window.

9.2.2 Transition chart of view (1)

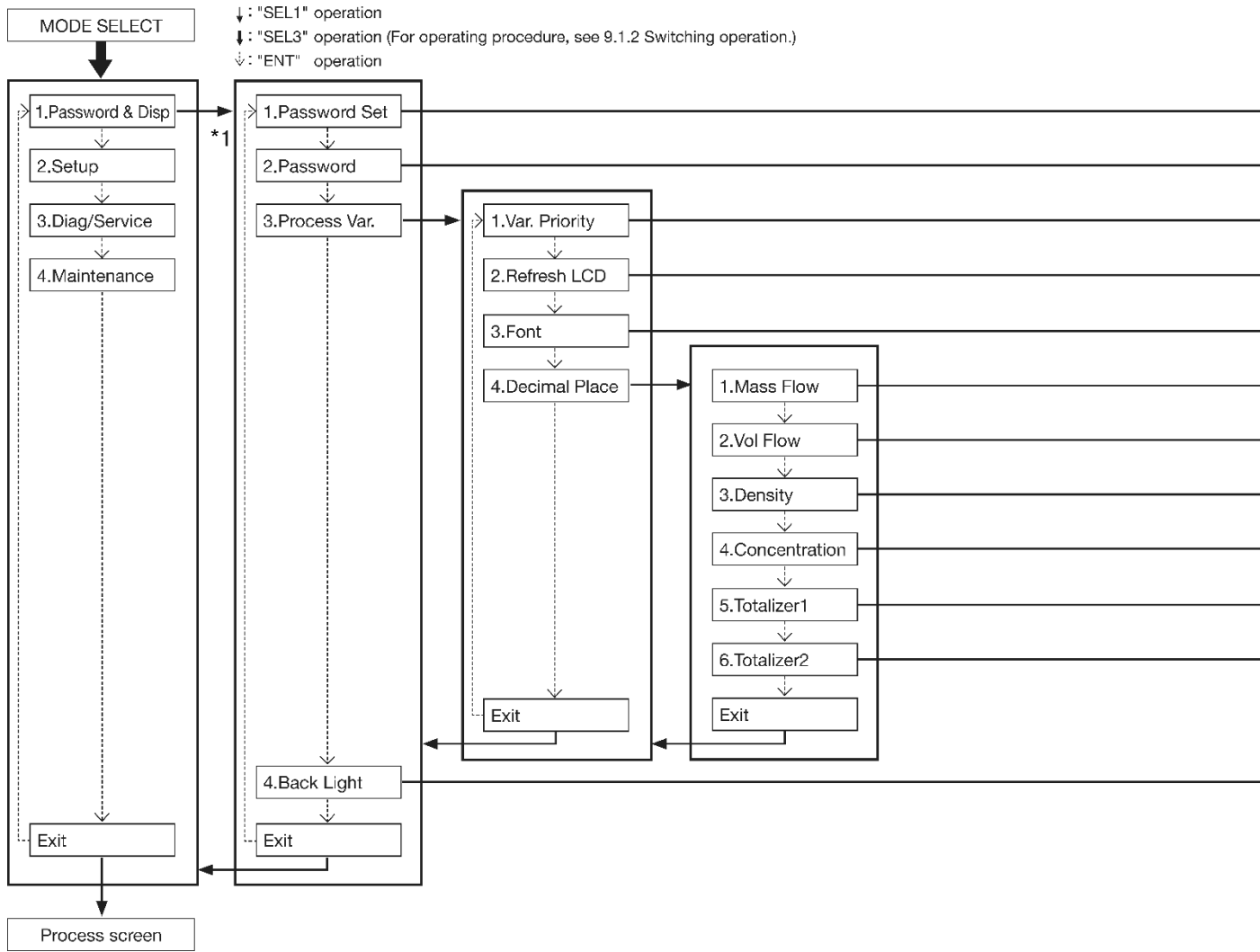

NOTE:

* 1 : For this function, the setting change is disabled in Write Protect mode (refer to section 9.2).

No.	Item	Description	Setup	Default
1-1	Password Set	Selects password active/inactive. With "ON" selected, entering a password is requested before entering setup menu screen from "MODE SELECT" screen. This prevents unauthorized password change. For details of password, see 9.5 Password Function.	See 9.4	Off
1-2	Password	Sets a password. To validate the setting, password function in [No. 1-1] requires to be turned "ON". A precaution to remember: If password is forgotten, there will be no way to change parameters.	See 9.3	9999
1-3-1	Var. Priority	Selects run indicator display/hidden and priority of variables view. For details, see 9.1.1 Variables view screen setup.	See 9.11	
1-3-2	Refresh LCD	Changes LCD display refresh rate (ms). Select one from 1: 100ms, 2: 200ms, 3: 500ms, 4: 1000ms, or 5: 2000ms. Select a slower rate if the reading changes too fast, making it difficult to read; select a faster rate if prompt readout is desired.	See 9.4	500ms
1-3-3	Font	Changes LCD font size. 1: Double angle ⇒ Larger font, allowing 2 variables view in one screen. 2: Normal ⇒ Smaller font, allowing 3 variables view in one screen.	See 9.4	Double
1-3-4-1	Mass Flow	Changes dcml pt. pos. in LCD instant mass rate. Select one that matches instant mass rate used. Select from 1: Auto ⇒ Auto (from 5th dcml. plc. to no fractions, 2: Integer ⇒ No fractions, 3: 1st decimal ⇒ to 1st dcml place, 4: 2nd decimal ⇒ to 2nd dcml plc., 5: 3rd decimal ⇒ to 3rd dcml plc., 6: 4th decimal ⇒ to 4th dcml plc.	See 9.4	Auto
1-3-4-2	Vol Flow	Changes dcml pt. pos. in instant volume rate on LCD. Select one that matches instant mass rate used. Select from 1: Auto ⇒ Automatic, 2: Integer ⇒ No fractions, 3: 1st decimal ⇒ to 1st dcml place, 4: 2nd decimal ⇒ to 2nd dcml plc., 5: 3rd decimal ⇒ to 3rd dcml plc., 6: 4th decimal ⇒ to 4th dcml plc.	See 9.4	Auto
1-3-4-3	Density	Changes LCD decimal point position in density. Set to match the density used. Selectable from 1: Auto ⇒ Automatic, 2: Integer ⇒ No fractions, 3: 1st Decimal ⇒ to 1st dcml place, 4: 2nd Decimal ⇒ to 2nd dcml place, 5: 3rd Decimal ⇒ to 3rd dcml place, 6: 4th Decimal ⇒ to 4th dcml place.	See 9.4	4th Decimal
1-3-4-4	Concentration	Change LCD decimal point in concentration. Set to match the Concentration used. Selectable from 1: Auto ⇒ Automatic, 2: Integer ⇒ No fractions, 3: 1st Decimal ⇒ to 1st dcml place, 4: 2nd Decimal ⇒ to 2nd dcml place, 5: 3rd Decimal ⇒ to 3rd dcml place, 6: 4th Decimal ⇒ to 4th dcml place.	See 9.4	Auto
1-3-4-5	Totalizer1	Changes LCD decimal point position in total flow 1. Set to match the total flow 1 used. Selectable from 1: Auto ⇒ Automatic, 2: Integer ⇒ No fractions, 3: 1st Decimal ⇒ to 1st dcml place, 4: 2nd Decimal ⇒ to 2nd dcml place, 5: 3rd Decimal ⇒ to 3rd dcml place, 6: 4th Decimal ⇒ to 4th dcml place.	See 9.4	Auto
1-3-4-6	Totalizer2	Changes LCD decimal point position in total flow 2 on LCD. Set to match the total flow 1 used. Selectable from 1: Auto ⇒ Automatic, 2: Integer ⇒ fractions eliminated, 3: 1st Decimal ⇒ to 1st dcml place, 4: 2nd Decimal ⇒ to 2nd dcml place, 5: 3rd Decimal ⇒ to 3rd dcml place, 6: 4th Decimal ⇒ to 4th dcml place.	See 9.4	Auto

No.	Item	Description	Setup	Default
1-4	Back Light	Selects backlight mode. (In an erratic condition, it stays on or blinks depending on its nature.) 1: Off: Backlight stays off. 2: Sleep 5 min: Stays on for 5 min before it goes out. 3: Sleep 10 min: Stays on for 10 min before it goes out. 4: Sleep 20 min: Stays on for 20 min before it goes out. 5: Sleep 30 min: Stays on for 30 min before it goes out.	See 9.4	Sleep 20min

No.	Item	Description	Setup	Default
2-1-1	Mass Unit	Selects instant mass flowrate unit. For available units of measure, see 9.18 Available setup units. Units of flowrate-related views and settings keep track of the units selected.	See 9.4	kg/min
2-1-2	Vol Unit	Selects unit of instant volume flowrate. For available units of measure, see 9.18 Available setup units. Flowrate-related units of measure and settings keep track of the units selected.	See 9.4	L/min
2-1-3	Flow Damp	Changes instant flowrate damping factor (sec). If flowrate fluctuates excessively, select a larger value; if fast response is desired, select a smaller value (0 to 200 sec).	See 9.3	0.8
2-1-4	Flow Cutoff	Changes cutoff (%) of instant mass rate. With respect to the cutoff rate multiplied by max allowable instant mass rate and cutoff rate, instant rate is clamped at 0 within the range where - cutoff rate < instant mass rate < +cutoff rate. If flowrate fluctuates excessively, select a larger value; if measurement down to small flows is desired, select a smaller value (0 to 5%).	See 9.3	0.3
2-1-5	Flow Direct	Changes flow direction. 1: Forward ⇒ + flow when the fluid runs in the flow direction of sensor; - flow if the fluid runs opposite to the flow direction of sensor. 2: Reverse ⇒ - flow when the fluid runs in the flow direction of sensor; + flow if the fluid runs opposite to the flow direction of sensor.	See 9.4	Forward

No.	Item	Description	Setup	Default
2-2-1	Dens Unit	Selects density unit. For available units of measure, see 9.18 Available setup units. The unit of density-related views and settings keep track of the unit selected.	See 9.4	g/ml
2-2-2	Dens Damp	Changes density damping factor (sec). If density fluctuates excessively, select a larger value; if fast response is desired, select a smaller value.	See 9.3	4.0
2-2-3	Slug Low	Sets lower limit density (low end in normal density) for slug flow detection. Set a value smaller than expected flow density.	See 9.3	Liquid: 0.3
2-2-4	Slug High	Sets higher limit density (high end in normal density) for slug flow detection. Set a value larger than expected flow density.	See 9.3	Liquid: 2
2-2-5	Slug Duration	Sets the duration required for detecting slug flows. During the preset duration, if measured density falls below lower limit density [No. 2-2-3] or exceeds upper limit density [No. 2-2-4], it is identified as slug flow to indicate an alarm.	See 9.3	0
2-2-6-1	Dens Compen	Sets enable/disable of reference temp. conversion function on density. 1: Off ⇒ Reference temp. conv. function disabled. 2: On ⇒ Ref. temp. conv. function is activated based on the following formula and the obtained dens. value is used in the view and output, etc. Dens. after ref. temp. conv. = Measured dens. + {ref. temp. conv. factor [No. 2-2-6-2] × (fluid temp. - ref. temp. [No. 2-2-6-2])}	See 9.4	Off
2-2-6-2	Std Temp	Changes the ref. temperature (°C) of the ref. temperature conversion function. The setting is valid when selection [No. 2-2-6-1] of ref. temperature conversion function is active.	See 9.3	20.00
2-2-6-3	Exp Coef	Changes ref. temp. conversion factor ((g/ml/°C)) in the ref. temp. conversion function. The setting is valid when selection [No. 2-2-6-1] of ref. temperature conversion function is active.	See 9.3	0.00024
2-2-6-4	Settled Dens	Sets enable/disable of fixed density function. 1: Off ⇒ Fixed density function is inactive. 2: On ⇒ Irrespective of density measurement, the fixed density [No. 2-2-6-5] is reflected in the output. (True density is displayed as density value.) (With On selected, vol flow is suffixed with (s) to avoid confusion with true density volume output.	See 9.4	Off
2-2-6-5	Dens Value	Changes fixed density (g/ml) of fixed density function. The setting is valid when selection [No. 2-2-6-4] of fixed density function is active.	See 9.3	1.0000

No.	Item	Description	Setup	Default
2-3-1	Temp Unit	Selects temperature unit of measure. For available units, see 9.18 Available setup units. The unit of temperature-related views and settings keeps track of the unit selected.	See 9.4	°C
2-3-2	Temp Damp	Changes temperature damping factor (sec). If temperature varies widely, select a larger value; if fast response is desired, select a smaller value.	See 9.3	4.0

No.	Item	Description	Setup	Default
2-4-1	Concent Gain	You can change the slope of the concentration measurement value.	See 9.3	Default 1
2-4-2	Concent Offset	You can change the offset of the concentration measurement value.	See 9.3	Default 0

9.2.4 Transition chart of view (3)

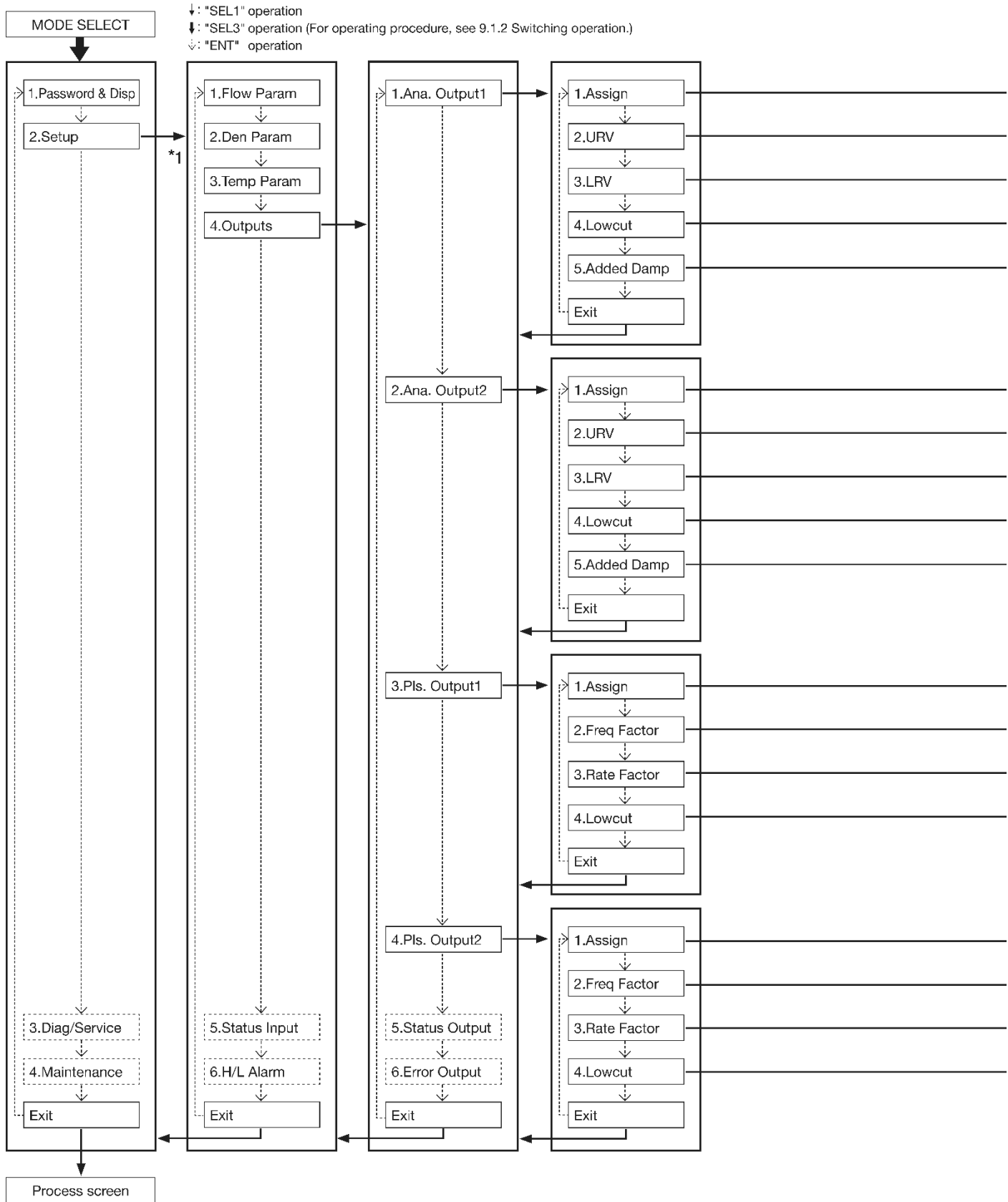

NOTE:

* 1 : For this function, the setting change is disabled in Write Protect mode (refer to section 9.2).

No.	Item	Description	Setup	Default
2-4-1-1	Assign	Changes analog output 1 assignment. (See 9.13 Analog Output Function.) If assignment is changed, reconfigure upper limit [No. 2-4-1-2], lower limit [No. 2-4-1-3], low cutoff [No. 2-4-1-4], and damping factor [No. 2-4-1-5] for optimum settings.	See 9.4	Mass Flow
2-4-1-2	URV	Changes analog output 1 upper limit. A 20mA output is produced at the value so set. A value smaller than lower limit [No. 2-4-1-3] and a value larger than max allowable range are not acceptable.	See 9.3	180.000
2-4-1-3	LRV	Changes analog output 1 lower limit. A 4mA output is produced at the value so set. A value larger than upper limit [No. 2-4-1-2] and a value larger than the max allowable range are not acceptable.	See 9.3	0.00000
2-4-1-4	Lowcut	Changes analog output 1 low cutoff (%). When low flow cutoff is greater than proportion of analog output where upper limit [No. 2-4-1-2] is set at 100% and lower limit [No. 2-4-1-3] at 0%, analog output is clamped at 4mA.	See 9.3	0.0
2-4-1-5	Added Damp	Changes analog output 1 damping factor (sec). If analog output 1 fluctuates excessively, select a larger value; if fast response is desired, select a smaller value.	See 9.3	0.0

No.	Item	Description	Setup	Default
2-4-2-1	Assign	Changes analog output 2 assignment. (See 9.13 Analog Output Function.) If assignment is changed, reconfigure upper limit [No. 2-4-2-2], lower limit [No. 2-4-2-3], low cutoff [No. 2-4-2-4], and damping factor [No. 2-4-2-5] for optimum settings.	See 9.4	Mass Flow
2-4-2-2	URV	Changes analog output 2 upper limit. A 20mA output is produced at the value so set. A value smaller than lower limit [No. 2-4-2-3] and a value larger than the max allowable range are not acceptable.	See 9.3	180.000
2-4-2-3	LRV	Changes analog output 2 lower limit. A 4mA output is produced at the value so set. A value larger than upper limit [No. 2-4-2-2] and a value larger than the max allowable range are not acceptable.	See 9.3	0.00000
2-4-2-4	Lowcut	Changes analog output 2 low cutoff (%). When low flow cutoff is greater than proportion of analog output where upper limit [No. 2-4-2-2] is set at 100% and lower limit [No. 2-4-2-3] at 0%, analog output is clamped at 4mA.	See 9.3	0.0
2-4-2-5	Added Damp	Changes analog output 2 damping factor (sec). If analog output 2 fluctuates excessively, select a larger value; if fast response is desired, select a smaller value.	See 9.3	0.0

No.	Item	Description	Setup	Default
2-4-3-1	Assign	Changes pulse output 1 assignment. (For functions, see 9.12 Pulse Output Function.) If assignment is changed, reconfigure frequency at full scale [No. 2-4-3-2], full scale flowrate [No. 2-4-3-3], and low cutoff [No. 2-4-3-4] for optimum settings.	See 9.4	Mass Flow
2-4-3-2	Freq Factor	Changes the max frequency of pulse output 1. An output is produced at the frequency (duty 50%) set at full scale [No. 2-4-3-3]. Set up to match the measuring frequency range of instrument used for pulse output measurement.	See 9.3	1000.0
2-4-3-3	Rate Factor	Changes pulse output 1 full scale flowrate. An output is produced at the max frequency [No. 2-4-3-2] when preset flowrate is reached.	See 9.3	180.000
2-4-3-4	Lowcut	Changes low cutoff (%) of pulse output 1. When proportion of flowrate falls below low cutoff where full scale flowrate [No. 2-4-3-3] is set at 100%, the pulse output is clamped at 0.	See 9.3	0.0

No.	Item	Description	Setup	Default
2-4-4-1	Assign	Changes pulse output 2 assignment. (For functions, see 9.12 Pulse Output Function.) If assignment is changed, reconfigure frequency at full scale [No. 2-4-4-2], full scale flowrate [No. 2-4-4-3], and low cutoff [No. 2-4-4-4] for optimum settings.	See 9.4	Mass Flow
2-4-4-2	Freq Factor	Changes the max frequency of pulse output 2. An output is produced at the frequency (duty 50%) set at full scale rate [No. 2-4-4-3]. (If double pulse output is your option at pulse output 2 assignment [No. 2-4-4-1], this setting becomes invalid, however.)	See 9.3	1000.0
2-4-4-3	Rate Factor	Changes pulse output 2 full scale flowrate. An output is produced at max freq. [No. 2-4-4-1] when preset rate is reached. (If double pulse output is your option at pulse output 2 assignment [No. 2-4-4-1], this setting becomes invalid, however.)	See 9.3	180.0
2-4-4-4	Lowcut	Changes pulse output 2 low cutoff (%). When proportion of flowrate falls below low cutoff where full scale flowrate [No. 2-4-4-3] is set at 100%, the pulse output is clamped at 0 (zero).	See 9.3	0.0

9.2.5 Transition chart of view (4)

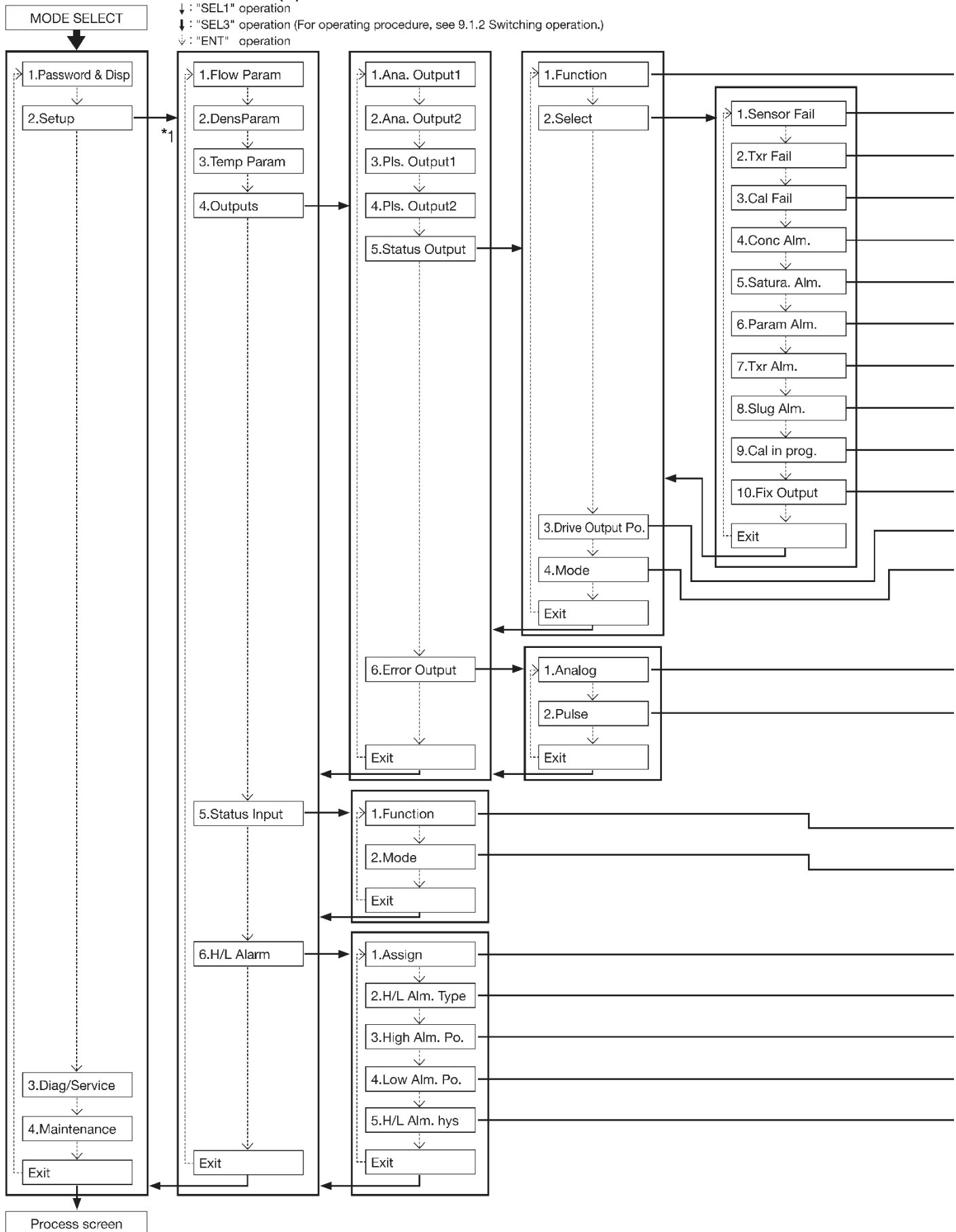

NOTE:

* 1 : For this function, the setting change is disabled in Write Protect mode (refer to section 9.2).

No.	Item	Description	Setup	Default
2-4-5-1	Function	Changes status output assignment. (For detail, see 9.14 Status Output Function.)	See 9.4	Error Status
2-4-5-2-1	Sensor Fail	1: Off ⇒ No assignment to status output, 2: On ⇒ Sensor Fail state is assigned to status output. No output appears unless Status Out is selected at status output function assignment [No. 2-4-5-1], however. For detail of Sensor Fail, see 10.1 Error Messages.	See 9.4	Off
2-4-5-2-2	Txr Fail	1: Off ⇒ No assignment to status output, 2: On ⇒ Txr Fail state is assigned to status output. No output appears unless Status Out is selected at status output function assignment [No. 2-4-5-1], however. For detail of Txr Fail, see 10.1 Error Messages.	See 9.4	Off
2-4-5-2-3	Cal Fail	1: Off ⇒ No assignment to status output, 2: On ⇒ Calibration Fail state is assigned to status output. No output appears unless Status Out is selected at status output function assignment [No. 2-4-5-1], however. For detail of Calibration Fail, see 10.1 Error Messages.	See 9.4	Off
2-4-5-2-4	Conc Alm.	1: Off ⇒ No assignment to status output, 2: On ⇒ Parameter alarm state is assigned to status output. No output appears unless Status Out is selected at status output function assignment [No. 2-4-5-1], however. For detail of Concentration alarm, see 10.1 Error Messages.	See 9.4	Off
2-4-5-2-5	Satura. Alm.	1: Off ⇒ No assignment to status output, 2: On ⇒ Saturated alarm state is assigned to status output. No output appears unless Status Out is selected at status output function assignment [No. 2-4-5-1], however. For detail of Saturation alarm, see 10.1 Error Messages.	See 9.4	Off
2-4-5-2-6	Param Alm.	1: Off ⇒ No assignment to status output, 2: On ⇒ Parameter alarm state is assigned to status output. No output appears unless Status Out is selected at status output function assignment [No. 2-4-5-1], however. For detail of Parameter alarm, see 10.1 Error Messages.	See 9.4	Off
2-4-5-2-7	Txr Alm.	1: Off ⇒ No assignment to status output, 2: On ⇒ Txr alarm state is assigned to status output. No output appears unless Status Out is selected at status output function assignment [No. 2-4-5-1], however. For detail of Txr alarm, see 10.1 Error Messages.	See 9.4	Off
2-4-5-2-8	Slug Alm.	1: Off ⇒ No assignment to status output, 2: On ⇒ Slug alarm state is assigned to status output. No output appears unless Status Out is selected at status output function assignment [No. 2-4-5-1], however. For detail of Slug alarm, see 10.1 Error Messages.	See 9.4	On
2-4-5-2-9	Cal in prog.	1: Off ⇒ No assignment to status output, 2: On ⇒ Cal in Progress state is assigned to status output. No output appears unless Status Out is selected at status output function assignment [No. 2-4-5-1], however. For detail of Cal in Progress, see 10.1 Error Messages.	See 9.4	Off
2-4-5-2-10	Fix Output	1: Off ⇒ No assignment to status output, 2: On ⇒ Fix output state is assigned to status output. No output appears unless Status Out is selected at status output function assignment [No. 2-4-5-1], however. For detail of Fix output, see 10.1 Error Messages.	See 9.4	Off
2-4-5-3	Drive Output Po.	The threshold value of a drive output can be set up.	See 9.4	100
2-4-5-4	Mode	1: Off Active⇒With Status output condition "ON", status output is turned off. 2: On Active⇒With Status output condition "ON", status output is turned on.	See 9.4	Off Active

No.	Item	Description	Setup	Default
2-4-6-1	Analog	Selects analog output pattern when an alarm condition occurs (sensor failure, Txr failure, or parameter alarm). 1: Downscale ⇒ Produces 2.4mA, 2: Zero ⇒ Produces 4mA, 3: Hold ⇒ Produces analog value as it is in an error, 4: Upscale ⇒ Produces 21.6mA.	See 9.4	Downscale
2-4-6-2	Pulse	Selects pulse output pattern in an error (sensor failure, Txr failure, or parameter alarm). 1: Zero ⇒ Stops pulse output, 2: Hold ⇒ Produces pulse output value as it is in an error, 3: Upscale ⇒ Produces an 11kHz output.	See 9.4	Zero

No.	Item	Description	Setup	Default
2-5-1	Function	Changes status input assignment. (See 9.15 Status input functions.)	See 9.4	No function
2-5-2	Mode	Selects status input operating conditions. 1: Short Active ⇒ Means that status input is shorted and action begins. 2: Open Active ⇒ Means that status input is open and action begins.	See 9.4	Short Active

No.	Item	Description	Setup	Default
2-6-1	Assign	Changes H/L alarm assignment. (See 9.16 High low alarm functions.) To validate this setting, it is necessary that H/L alarm be selected at status output assignment.	See 9.4	Mass Flow
2-6-2	H/L Alm. Type	Selects type of H/L alarm. 1: High alarm ⇒ High alarm is active, 2: Low alarm ⇒ Low alarm is active, 3: H/L alarm ⇒ Both high and low alarms are active.	See 9.4	High Alarm
2-6-3	High Alm. Po.	Changes high alarm setting. A value exceeding this setting activates high alarm; when it falls below this setting by H/L alarm hysteresis [No. 2-6-5], high alarm condition is reset. A setting smaller than low alarm [No. 2-6-4] is not acceptable.	See 9.3	0.0
2-6-4	Low Alm. Po.	Changes low alarm setting. A value falling below this setting activates low alarm; when it exceeds this setting by H/L alarm hysteresis [No. 2-6-5], low alarm condition is reset. A setting smaller than high alarm [No. 2-6-3] is not acceptable.	See 9.3	0.0
2-6-5	H/L Alm. hys	Changes high/low alarm hysteresis setting. Frequent annoying false alarms (repetitive alarm on/off in short duration) can be alleviated by choosing a larger value. To get an accurate picture of alarm condition, choose a smaller value.	See 9.3	0

9.2.6 Transition chart of view (5)

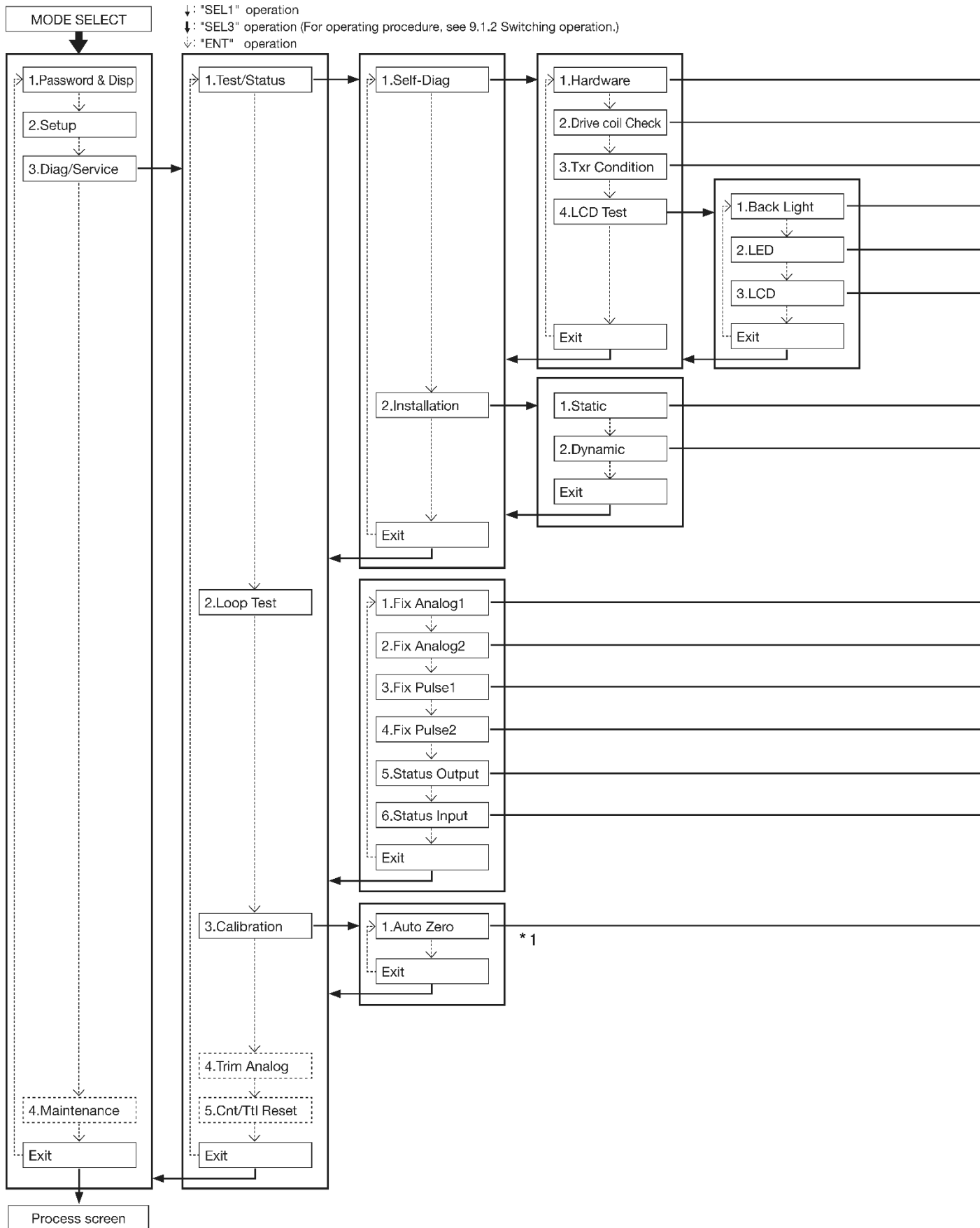

NOTE:

* 1 : For this function, the setting change is disabled in Write Protect mode (refer to section 9.2).

No.	Item	Description	Setup	Default
3-1-1-1	Hardware	Runs a check for possible problems in the probe. For details, see 9.6.1 Probe check. CAUTION: Be very careful as this check can stop outputs under certain circumstances.	See 9.6.1	—
3-1-1-2	Drive coil Check	Runs a check for an "open" in the drive coil. For details, see 9.6.2 Drive coil check. CAUTION: Be very careful as this check can stop outputs under certain circumstances.	See 9.6.2	—
3-1-1-3	Txr Condition	Runs a check for possible problems in the transmitter. For details, see 9.6.3 Transmitter check.	See 9.6.3	—
3-1-1-4-1	Back Light	Tests backlight for possible problems by forcibly turning it on and off. While test continues, the LCD remains dead. Performance test consist of WHT backlight lit (3 sec), ORG backlight lit (3 sec) and backlight unlit (3 sec) conducted twice one after the other (total of 18 sec) and ends automatically. After the test, the LCD restores normal illumination.	See 9.4	—
3-1-1-4-2	LED	Tests LEDs for possible problems by forcibly turning them on and off. While test continues, the LCDs remain dead. Performance test consist of RED LED lit (1.5 sec) and GRN LED lit (1.5 sec) conducted 6 times alternately (total of 18 sec) and ends automatically. After the test, the LCDs restore normal illumination.		—
3-1-1-4-3	LCD	Tests LCD for possible problems by illuminating and extinguishing all LCD dots. While test continues, the LCDs are forcibly switched in and out. Performance test consist of all dots lit (3 sec) and all dots unlit (3 sec) conducted twice alternately and ends automatically (a total of 12 sec). After the test, the LCDs restore normal illumination.		—

No.	Item	Description	Setup	Default
3-1-2-1	Static	Runs a check for stability of sensor signal at zero flow. For details, see 9.6.4 Pipeline oscillation check (zero flow).	See 9.6.4	—
3-1-2-2	Dynamic	Runs a check for stability of sensor signal while allowing the fluid. For details, see 9.6.5 Pipeline oscillation check (fluid flowing).	See 9.6.5	—

No.	Item	Description	Setup	Default
3-2-1	Fix Analog1	Produces a simulated output of analog output 1. It is beneficial for testing cable fault and performance of associated equipment. For details, see 9.7.1 Analog output.	See 9.7.1	—
3-2-2	Fix Analog2	Produces a simulated output of analog output 2. It is beneficial for testing cable fault and performance of associated equipment. For details, see 9.7.1 Analog output.	See 9.7.1	—
3-2-3	Fix Pulse1	Produces a simulated output of pulse output 1. It is beneficial for testing cable fault and performance of associated equipment. For details, see 9.7.2 Pulse output.	See 9.7.2	—
3-2-4	Fix Pulse2	Produces a simulated output of pulse output 2. It is beneficial for testing cable fault and performance of associated equipment. For details, see 9.7.2 Pulse output.	See 9.7.2	—
3-2-5	Status Output	Produces a simulated output of status output. It is beneficial for testing cable fault and performance of associated equipment. For details, see 9.7.3 Status output.	See 9.7.3	—
3-2-6	Status Input	Monitors status input. It is beneficial for testing cable fault and performance of associated equipment. For details, see 9.7.4 Status monitor input.	See 9.7.4	—

No.	Item	Description	Setup	Default
3-3-1	Auto Zero	Performs zeroing. When you perform zeroing, verify that the flow is at zero. For details, see 9.8 Zeroing Function.	See 9.8	—

9.2.7 Transition chart of view (6)

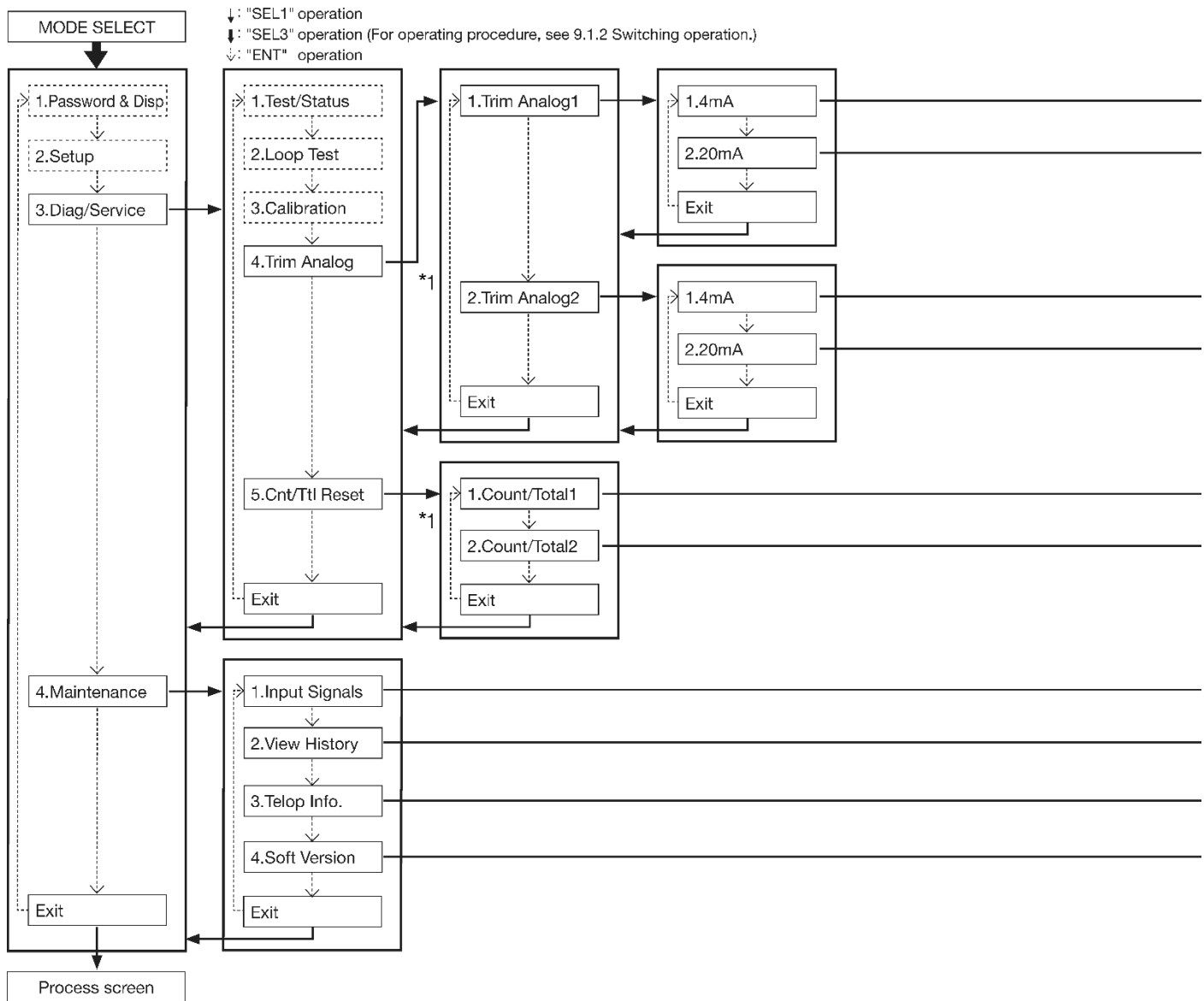

No.	Item	Description	Setup	Default
3-4-1-1	4mA	Trims 4mA analog output 1. It is factory adjusted and normally further adjustment is not required. However, if it is absolutely necessary, follow the procedure outlined. For details, see 9.9 Analog Output Trim.	See 9.9	—
3-4-1-2	20mA	Trims 20mA analog output 1. It is factory adjusted and normally further adjustment is not required. However, if it is absolutely necessary, follow the procedure outlined. For details, see 9.9 Analog Output Trim.	See 9.9	—

No.	Item	Description	Setup	Default
3-4-2-1	4mA	Trims 4mA analog output 2. It is factory adjusted and normally further adjustment is not required. However, if it is absolutely necessary, follow the procedure outlined. For details, see 9.9 Analog Output Trim.	See 9.9	—
3-4-2-2	20mA	Trims 20mA analog output 1. It is factory adjusted and normally further adjustment is not required. However, if it is absolutely necessary, follow the procedure outlined. For details, see 9.9 Analog Output Trim.	See 9.9	—

No.	Item	Description	Setup	Default
3-5-1	Count/Total1	Resets counter 1 and totalizer 1 reading to 0. For details, see 9.10 Reset Function.	See 9.10	—
3-5-2	Count/Total2	Resets counter 2 and totalizer 2 reading to 0. For details, see 9.10 Reset Function.	See 9.10	—

No.	Item	Description	Setup	Default
4-1	Input Signals	The screen is used for maintenance.	View only	—
4-2	View History	Shows the number of running hours of transmitter. Can be switched to calendar view. (Incorporated clock is maintenance oriented; No updating takes place if power to the transmitter is interrupted.)		—
4-3	Telop Info.	When the number of running hours exceeds 100,000, a black circle "●" begins to blink at lower left of LCD which can be canceled. 1: Off ⇒ "●" stays off irrespective of elapsed hours. 2: ON ⇒ warning "●" begins to blink after 100,000 hours.	See 9.4	ON
4-4	Soft Version	Shows the software version and checksum value.	View only	—

9.3 Parameter Value Entry

The procedure to enter a numerical data of parameters is described here. As an example, reconfiguring the temperature damping factor from "4.0" to "4.2" is covered in this section. A similar procedure applies to setting up other parameters.

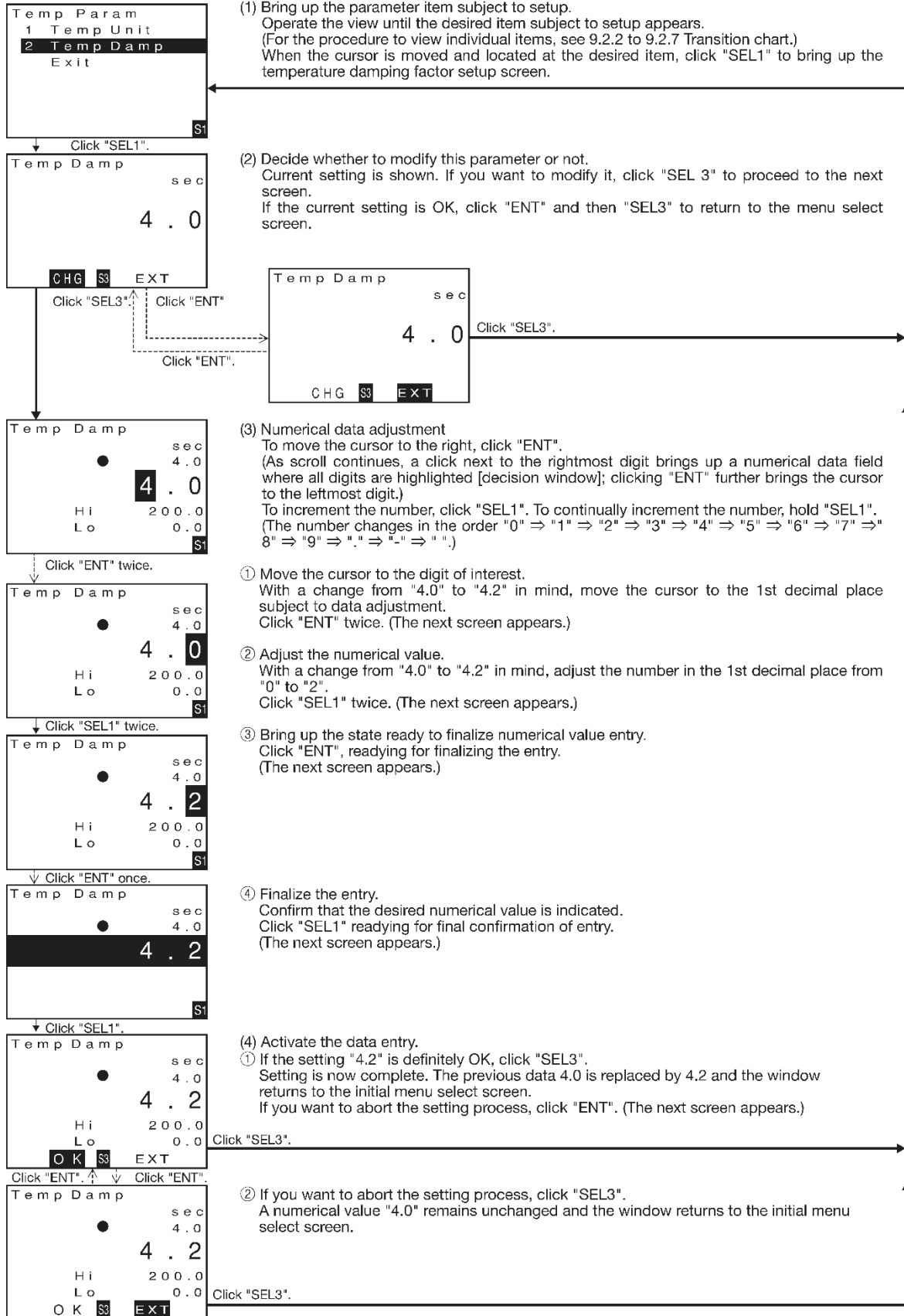

9.4 Parameter Selection

The procedure to select a menu item of parameters is described here. As an example, selecting "Kelvin" in temperature unit setting is covered in this section. A similar procedure applies to setting up other parameters.

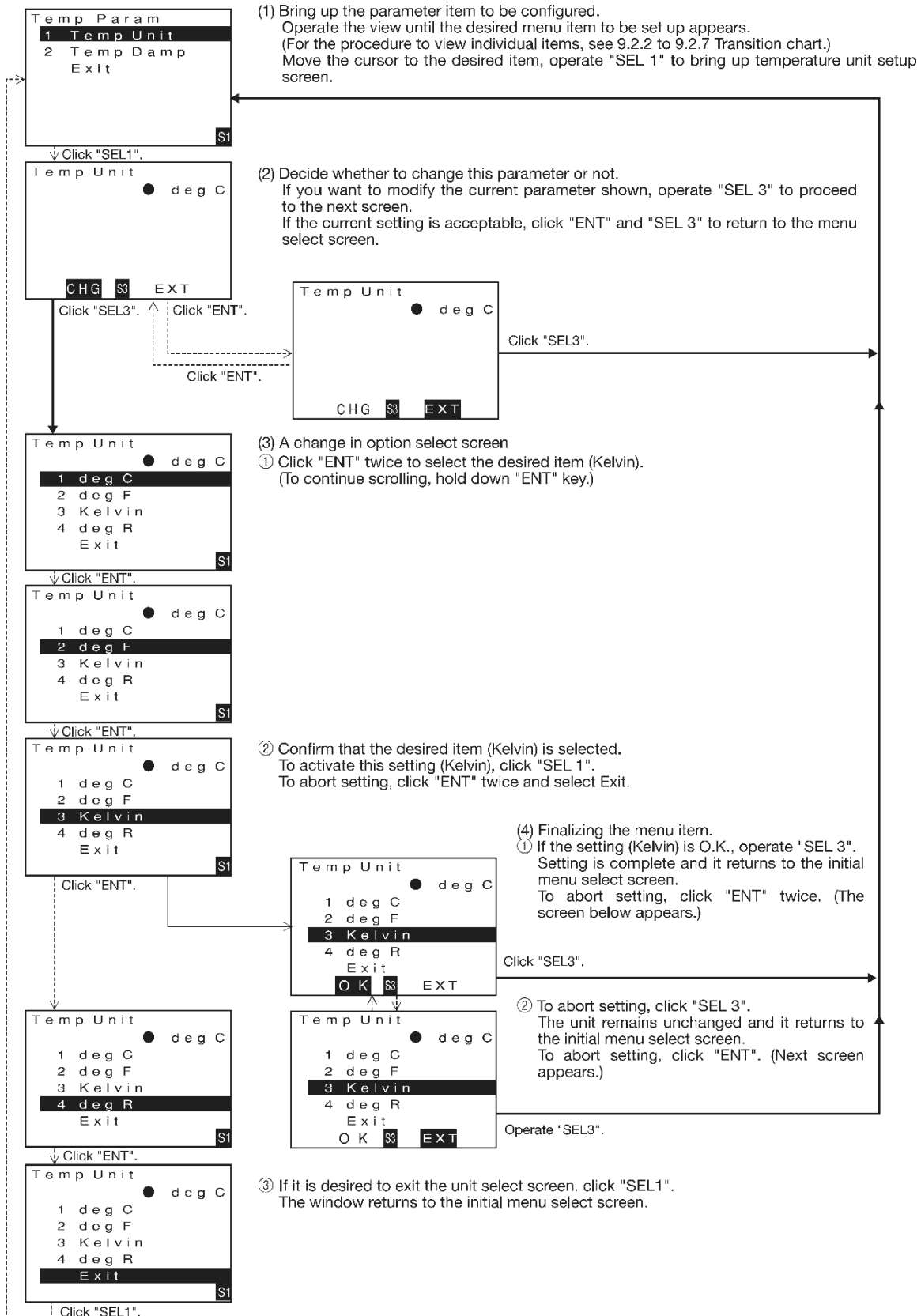

9.5 Password Function

NOTE: For this function, the setting change is disabled in Write Protect mode (refer to section 9.2).

To safeguard transmitter signals and readings against unauthorized parameter modification, you can configure the transmitter to request entering a password before bringing up the configuration screen.

9.5.1 Password function setup

To enable the password function, it is necessary that the following items be set up.

(1) Password function setting (Password Set) (See 9.2.2 Transition chart and description (1) [No. 1-1].) To activate password function, select "ON"; to deactivate it, select "OFF".

(2) Creating a password (Password) (See 9.2.2 Transition chart and Description (1) [No. 1-2].) Enter a 4-digit login password of numerals.

Once these settings are activated, entering a password is asked before any request for password modification. Use extra care in the setup process because if the user forgets his password, there will be no way to get to the reconfiguration screen.

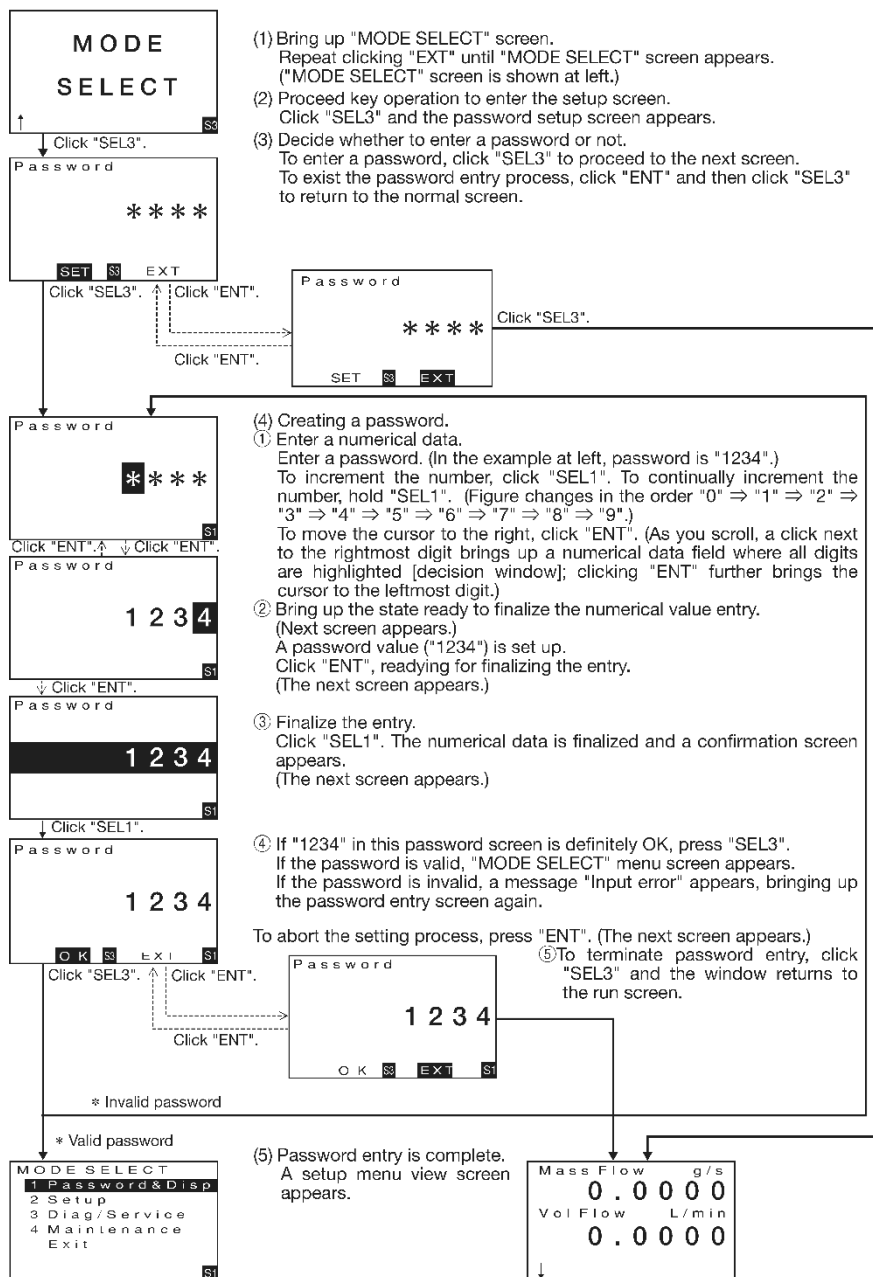

9.6 Self-diagnostic Capabilities

Comprehensive self-diagnostic capabilities are incorporated in this transmitter. To derive the maximum benefit from the instrument, make full use of these functions during maintenance and inspection for early identification of trouble or for investigation of the causes of trouble in a fault condition.

9.6.1 Probe check

A diagnostic test can be conducted to see if the transmitter is free from any problem in the probe circuitry. If an error is detected upon diagnosis, there is a possibility that it presents a risk to maintaining accurate measurement. You are prompted to follow the instructions given at an NG sign.

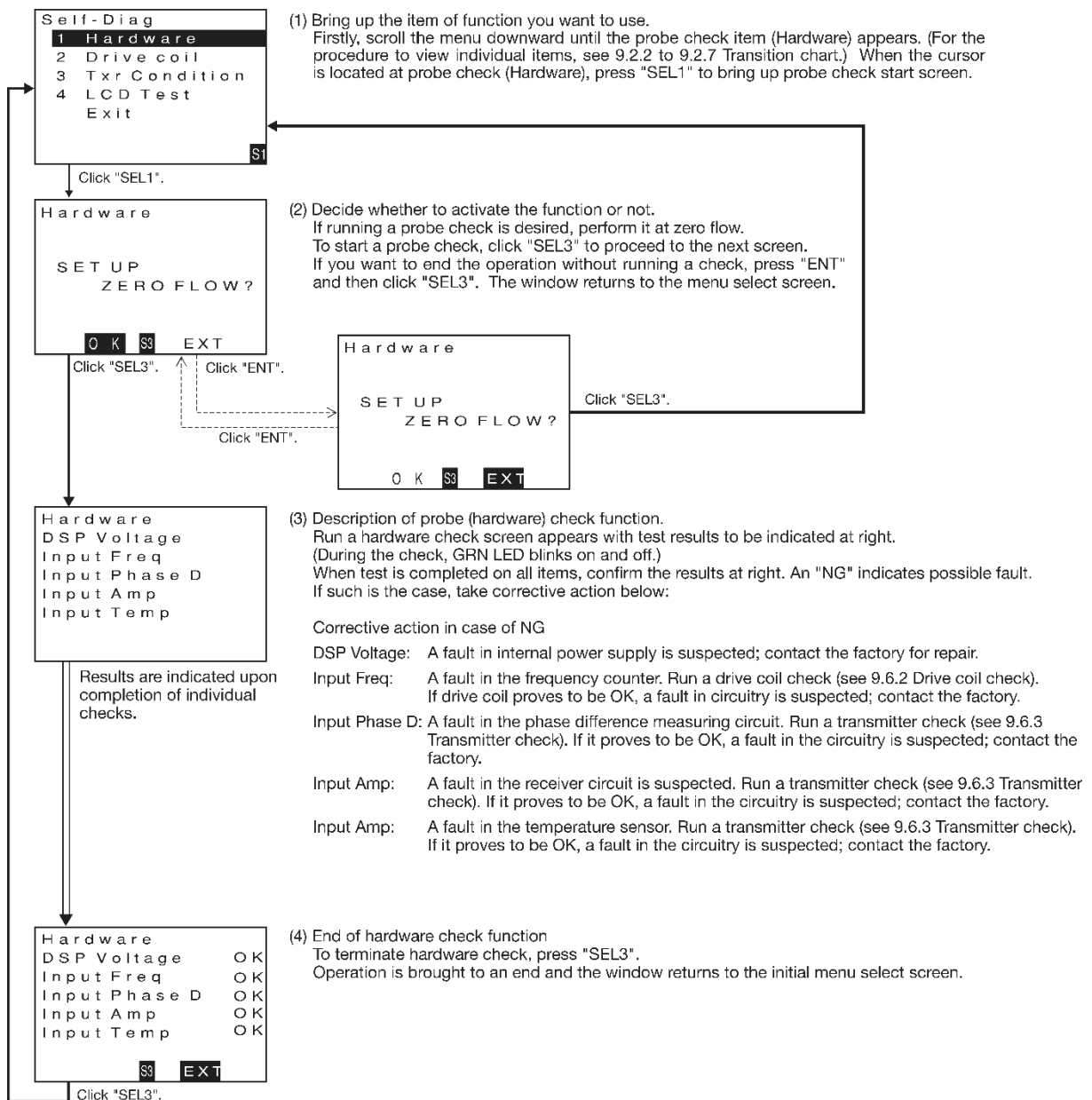

9.6.2 Drive coil check

A diagnostic test can be conducted to see if the drive coil is free from any problem. If an error is detected upon diagnosis, there is a possibility that it presents a risk to maintaining accurate measurement. You are prompted to follow the instructions given.

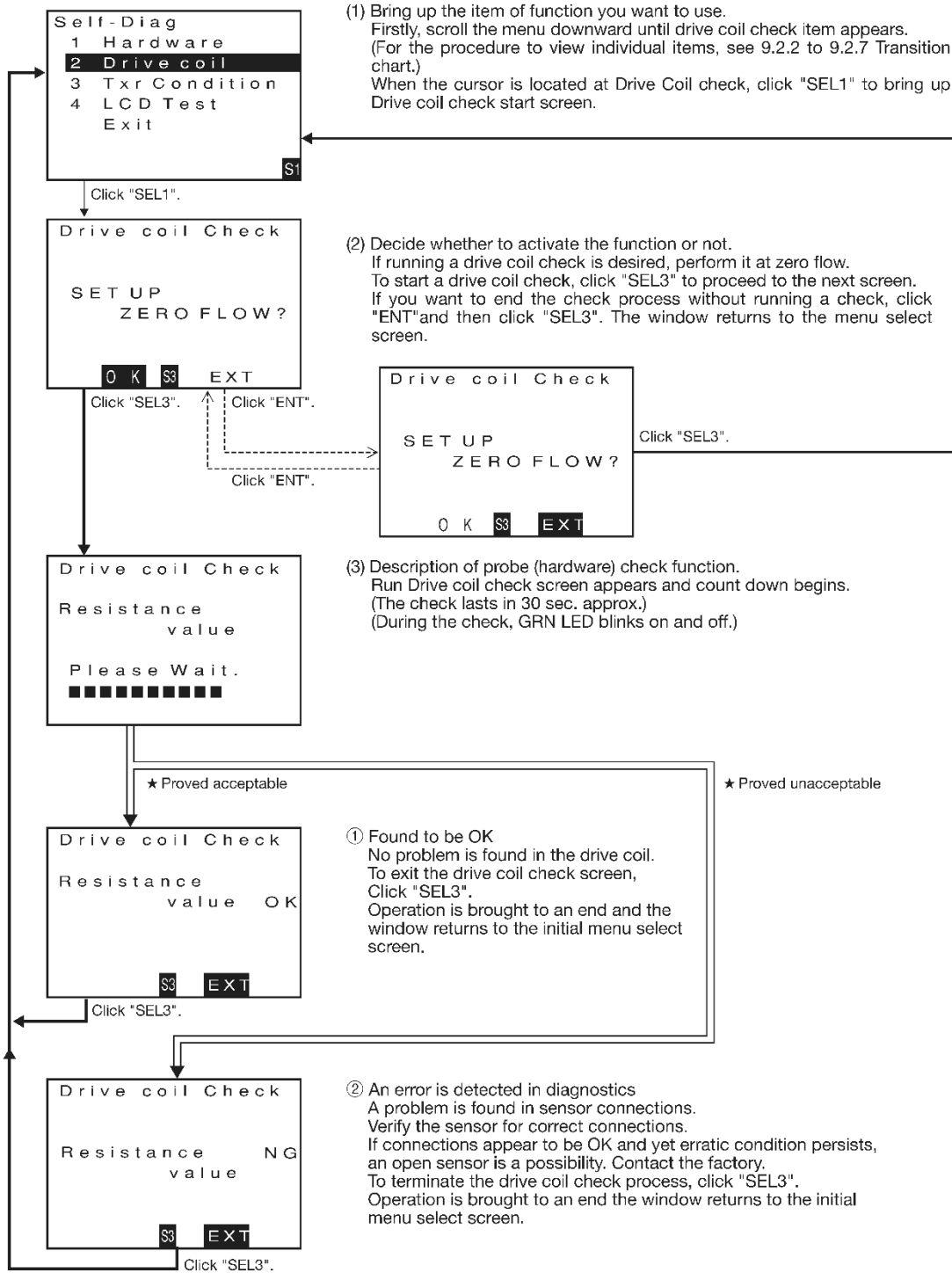

9.6.3 Transmitter check

A diagnostic test can be conducted to see if the transmitter is free from any problem. If an error is detected upon diagnosis, there is a possibility that it presents a risk to maintaining accurate measurement. You are prompted to follow the instructions given.

A precaution to remember: While the check is in progress, flow metering is disabled with flowrate at 0 (zero).

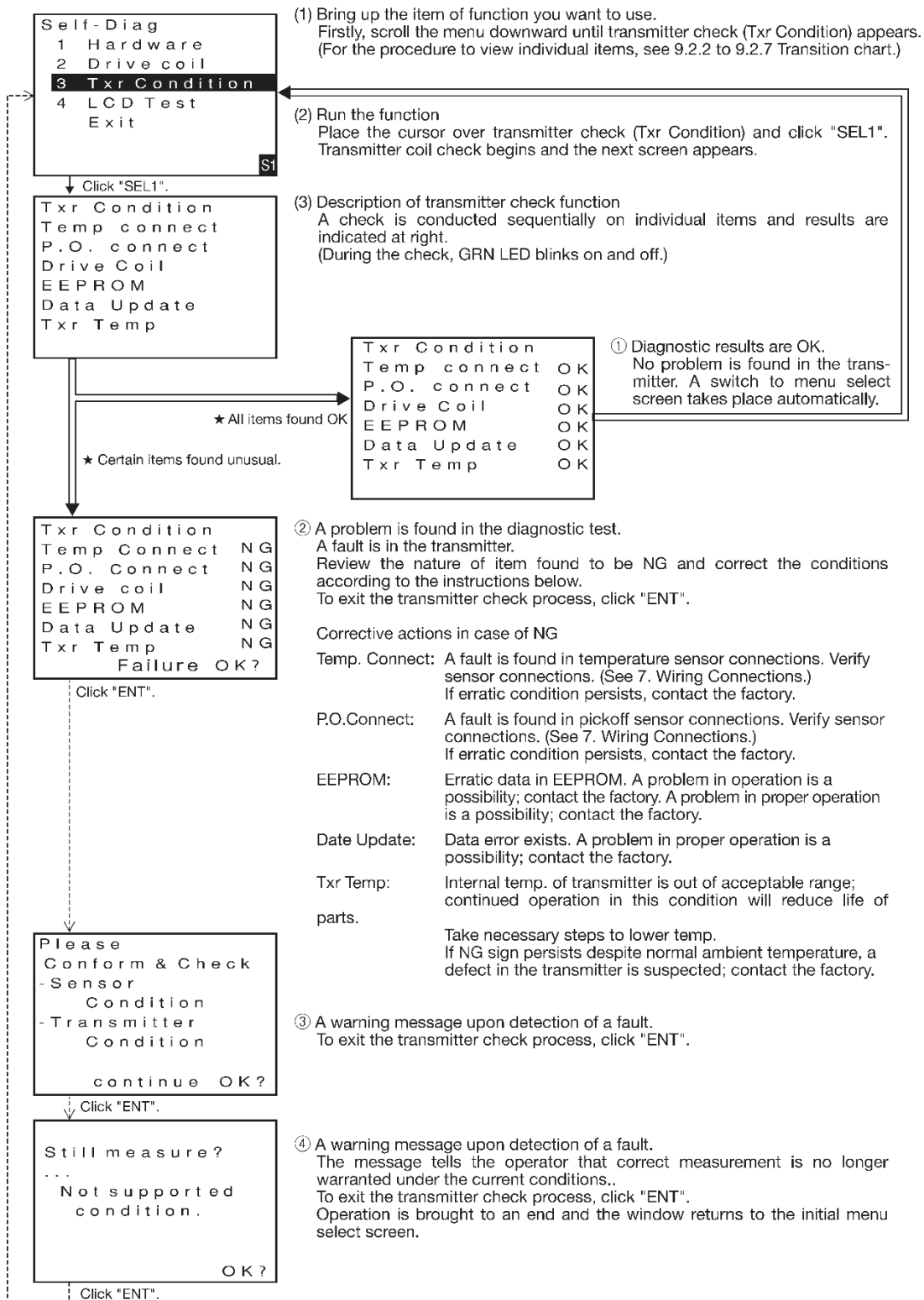

9.6.4 Pipeline vibration check (at zero flow)

This check diagnoses your flow measurement installation for condition – whether it is free from external disturbances and noises resulting from pipeline vibration or other factors. To be successful in obtaining accurate results, run the test at zero flow.

Upon completion of the check, diagnostic results will be indicated and you will be prompted to follow the instructions given.

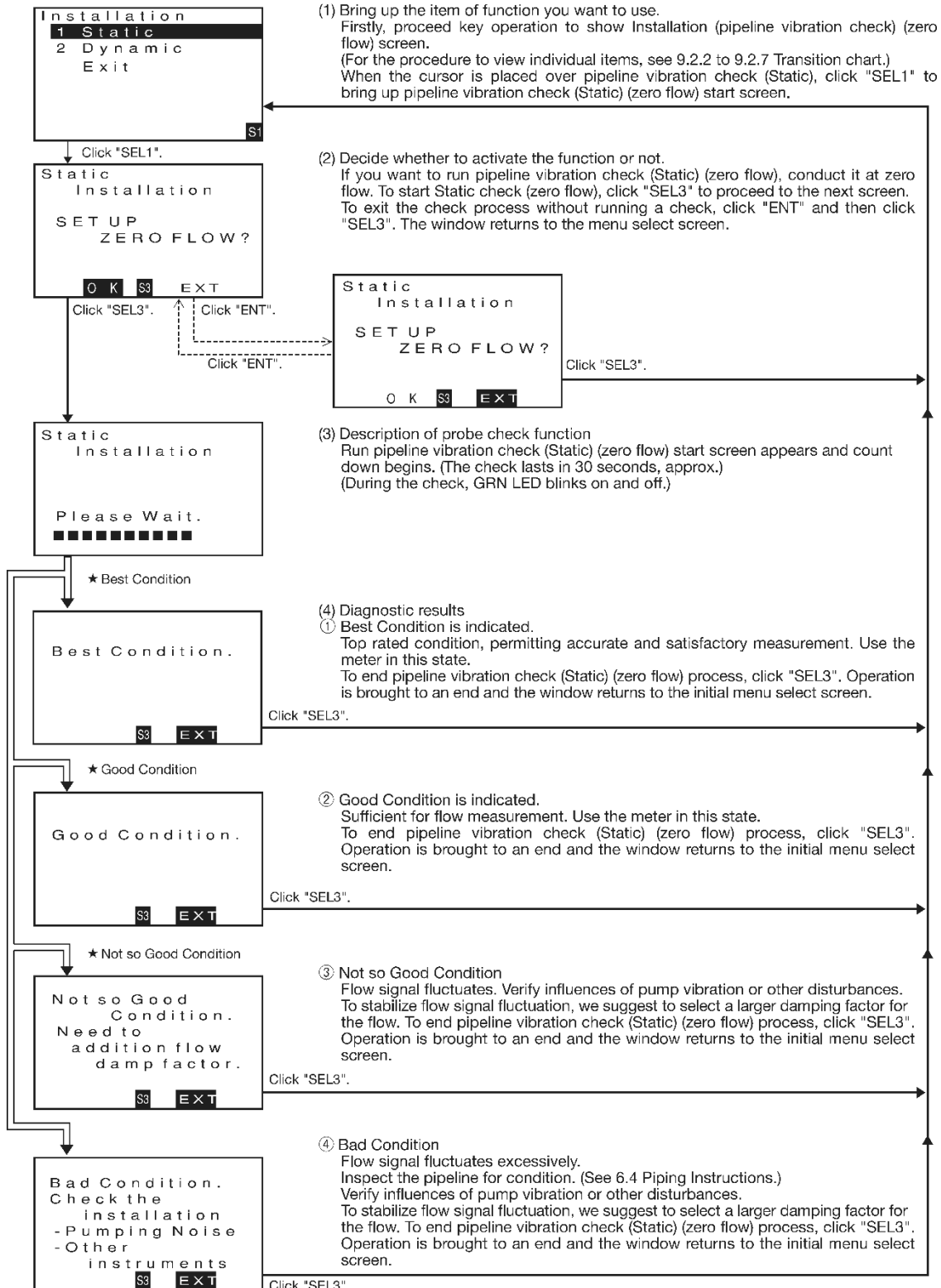

9.6.5 Pipeline oscillation check (at normal flow)

This check diagnoses your flow measurement installation for condition while allowing the fluid flow – whether it is free from external disturbances and noises resulting from pipeline vibration or other factors. Upon completion of the check, diagnostic results will be indicated and you will be prompted to follow the instructions given.

During the process of diagnosis, analog output and pulse output operations are suspended.

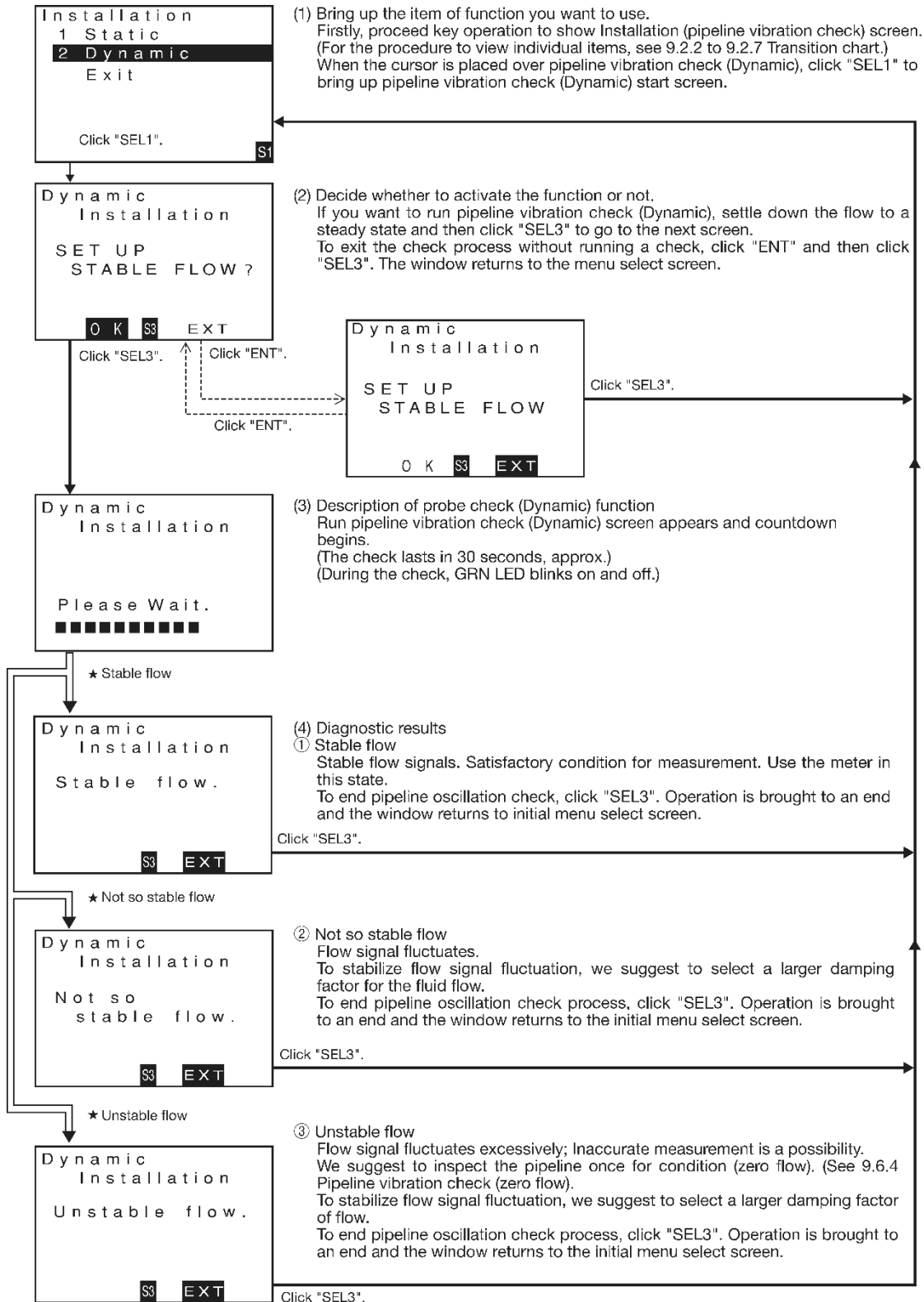

9.7 Simulated Signal Input/Output Capabilities

This transmitter features simulated output and input monitor functions. They are beneficial for running a loop check after installation and for diagnosing erratic flow signals.

9.7.1 Analog Output

An analog output is available at any current magnitude. (The procedure to provide a 12.00mA simulated output of analog output 1 is described here in the example below.)

(For key-in procedure, see 9.1.1 Key operation.)

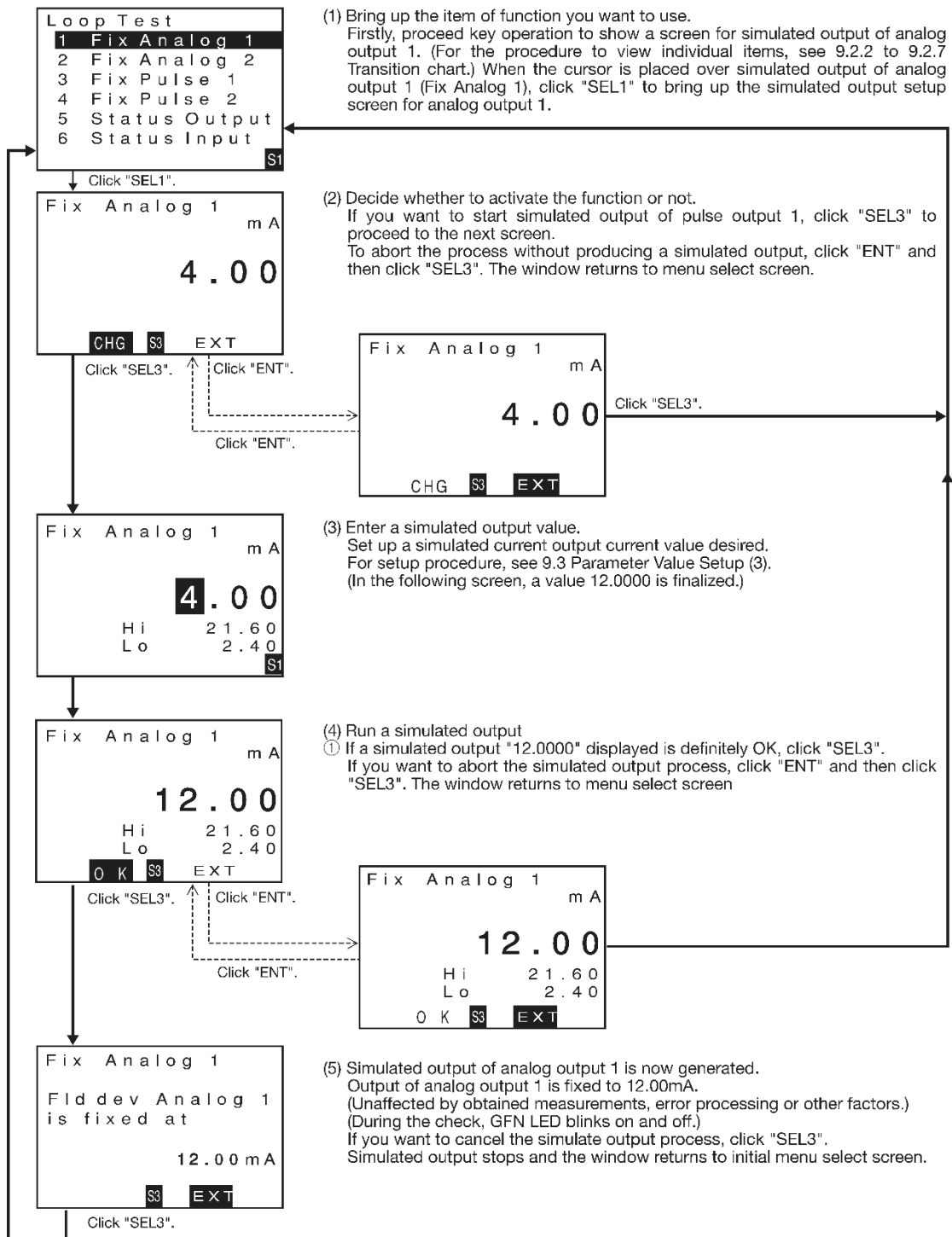

9.7.2 Pulse Output

A pulse output is available at any frequency desired. (Simulated output in pulse output 1 is described here in the example below.) This section covers the procedure to provide a 2100Hz simulated pulse output. A similar procedure applies to other output settings.

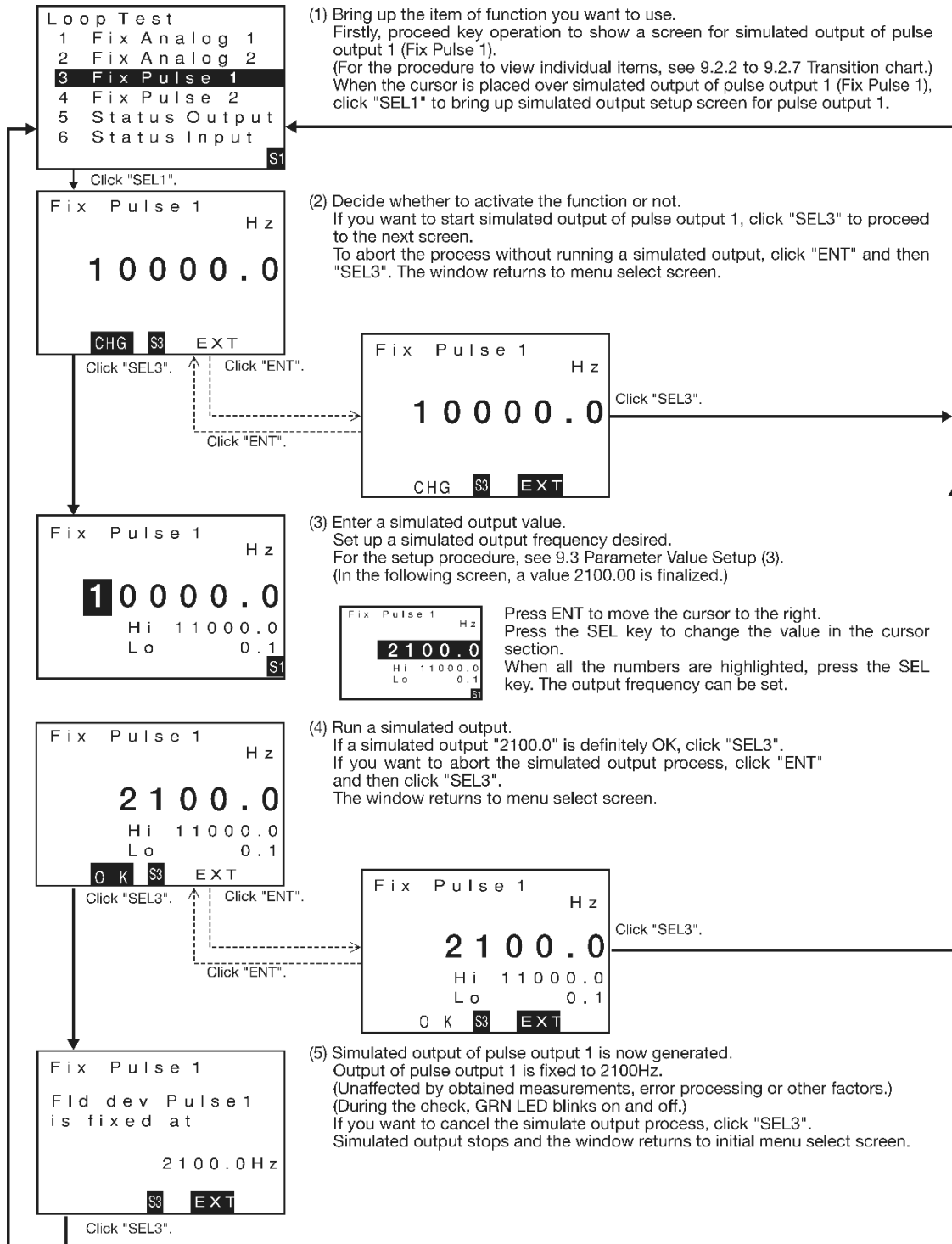

9.7.4 Status Input

You can monitor the status of status input signal.

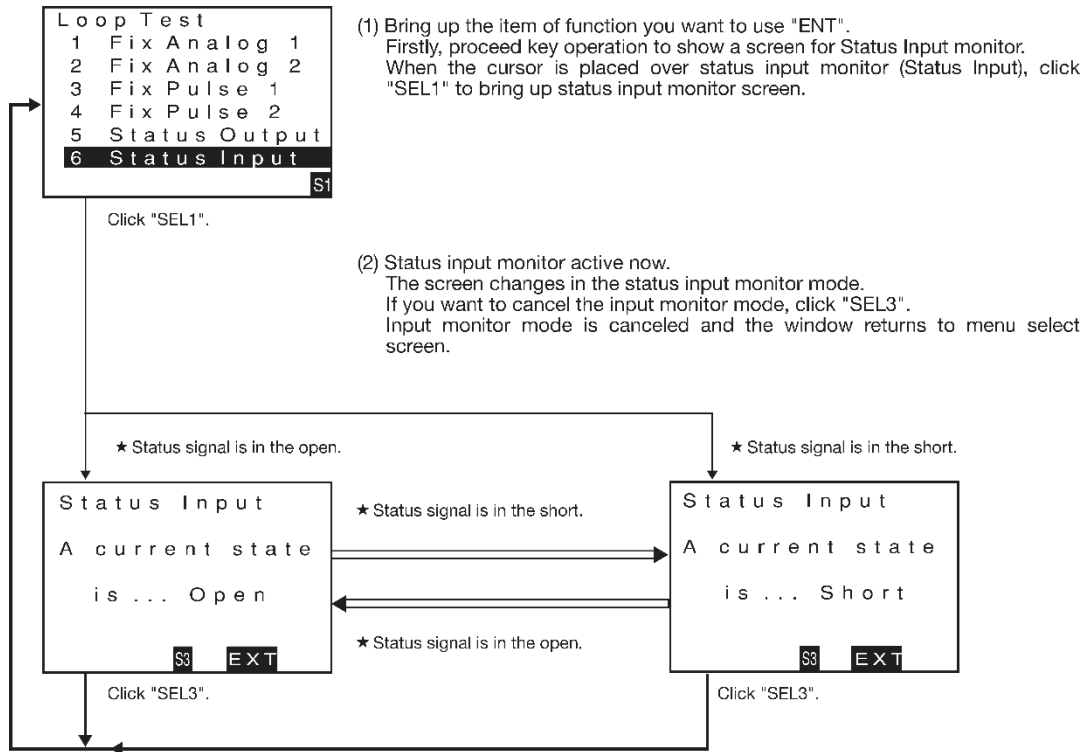

9.8 Zeroing Function

This feature detects errors in zeroing and reduces offset flowrate drift to minimum. At the stage of installation and in cases where flow conditions significantly change, zeroing is an essential part of the routines required for maintaining accurate and consistent measurement.

During the zeroing, fill the sensor unit completely with the fluid the temperature of which is within $\pm 10^{\circ}\text{C}$ from the temperature at which it operates.



CAUTION:

- 1. Before using this function, close both the display lid and the terminal lid of the transmitter and make sure that the transmitter is in the condition as the actual operating condition.**
- 2. Fluid (liquid) must completely fill the sensor unit and be absolutely at zero flow.**
- 3. Accurate zeroing cannot be achieved unless fluid flow is completely halted.**
- 4. Ensure that the shutoff valve has no leaks.**

Zero adjustment comes in three options: with LCD switches, with status input, and through communication. Each has identical functions. Choose one that best suits your task.

9.8.1 Through LCD display switches

NOTE: This function is disabled in Write Protect mode (refer to section 9.2).

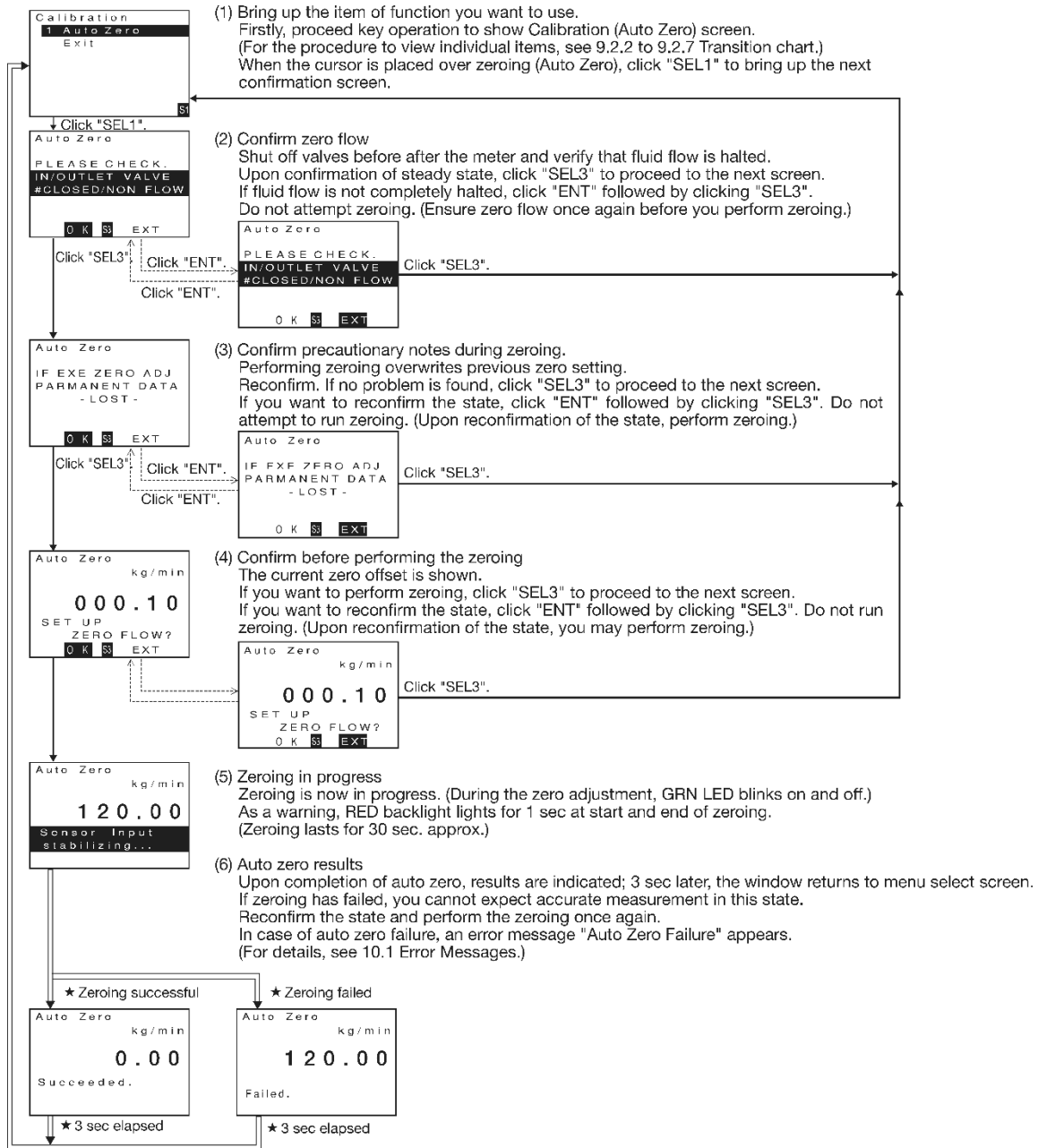

9.8.2 Through status input signal

You can perform the zeroing with status input signal. Follow the procedure given below for preparation and operation:

(1) Preparation to assign status input to zeroing

- Set status input function to "Auto Zero". (For details of setup, see 9.15 Status Input and 9.2.5 Transition chart (4) [No. 2-5-1].)
- Set input mode of status input. (For details of setup, see 9.15 Status Input and 9.2.5 Transition chart (4) [No. 2-5-2].)

(2) Preparation to assign zeroing in progress to status output

(You can perform the zeroing without this setting. You may omit this procedure if not required.) By completing the settings that follow, you can monitor the zeroing status with status output.

- Set function assignment of status output to "Error Status".
- Set adjustment item of status output to "On".
- Set working output of status output. (For detail of setup procedure, see 9.14.3 Status output and 9.2.5 Transition chart (4) [No. 2-4-5-1], [No. 2-4-5-2-8], and [No. 2-4-5-3].)

(3) Procedure to run the zeroing

By working with separately input, you can perform the zeroing. Follow the procedure outline below:

① Preparation

Verify the following precautions: During the zeroing, fill the sensor unit completely with the fluid the temperature of which is within $\pm 10^{\circ}\text{C}$ from the temperature at which it operates.

CAUTION:

- 1. Fluid (liquid) must completely fill the sensor unit and be absolutely at zero flow.**
- 2. Accurate zeroing cannot be achieved unless fluid flow is completely halted.**
- 3. Ensure that the shutoff valves, etc. have no leaks.**

② Run the zeroing: set the status input to 0.3 sec or longer in the "Short" (when input mode is "Short"). Upon detection of an input, the zeroing process starts and this process lasts in about 30 seconds.

In the event zeroing has failed, you cannot expect accurate measurement. Upon completion of zeroing, do not forget to run a check for possible errors.

9.8.3 Through L-Cor software communication

NOTE: This function is disabled in Write Protect mode (refer to section 9.2).

Zeroing can be conducted through communication, using the L-Cor Configuration Software. For detail of procedure, see the L-Cor software instruction manual.

9.9 Analog Trim Function

NOTE: This function is disabled in Write Protect mode (refer to section 9.2).

The transmitter is provided with two analog outputs. Both are factory adjusted and requires no further adjustment. However, if it is absolutely necessary to readjust, follow the instructions outlined below.

Prior to making adjustment, connect required measuring instruments in place for making output level measurement of analog output. Covered below is the procedure to make 4mA trim of analog output 1 (trimming 4.1mA to 4mA in the example below). A similar procedure applies to other adjustments.

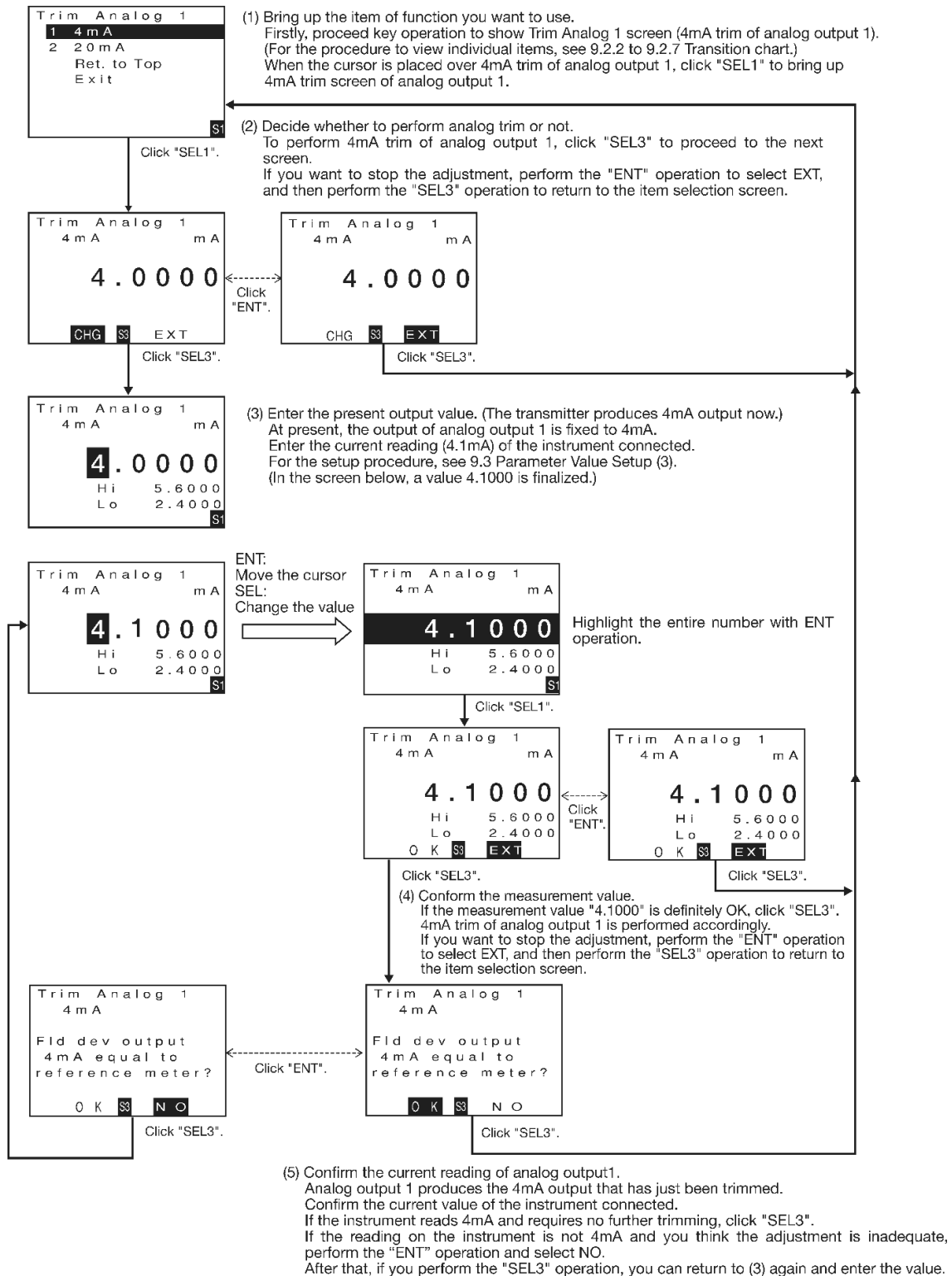

9.10 Reset Function

NOTE: This function is disabled in Write Protect mode (refer to section 9.2).

The transmitter is provided with two pulse outputs along with two counters (1 and 2) and two totalizers (1 and 2) which work in sync with pulse output. If it is desired to reset one particular counter and its associated totalizer, follow the procedure outlined below. (Since the totalizer counts pulses coming in from the counter, you cannot reset them independently.)

The procedure to reset the counter / totalizer 1 to 0 is described here as an example. The same procedure applies to the other pair.

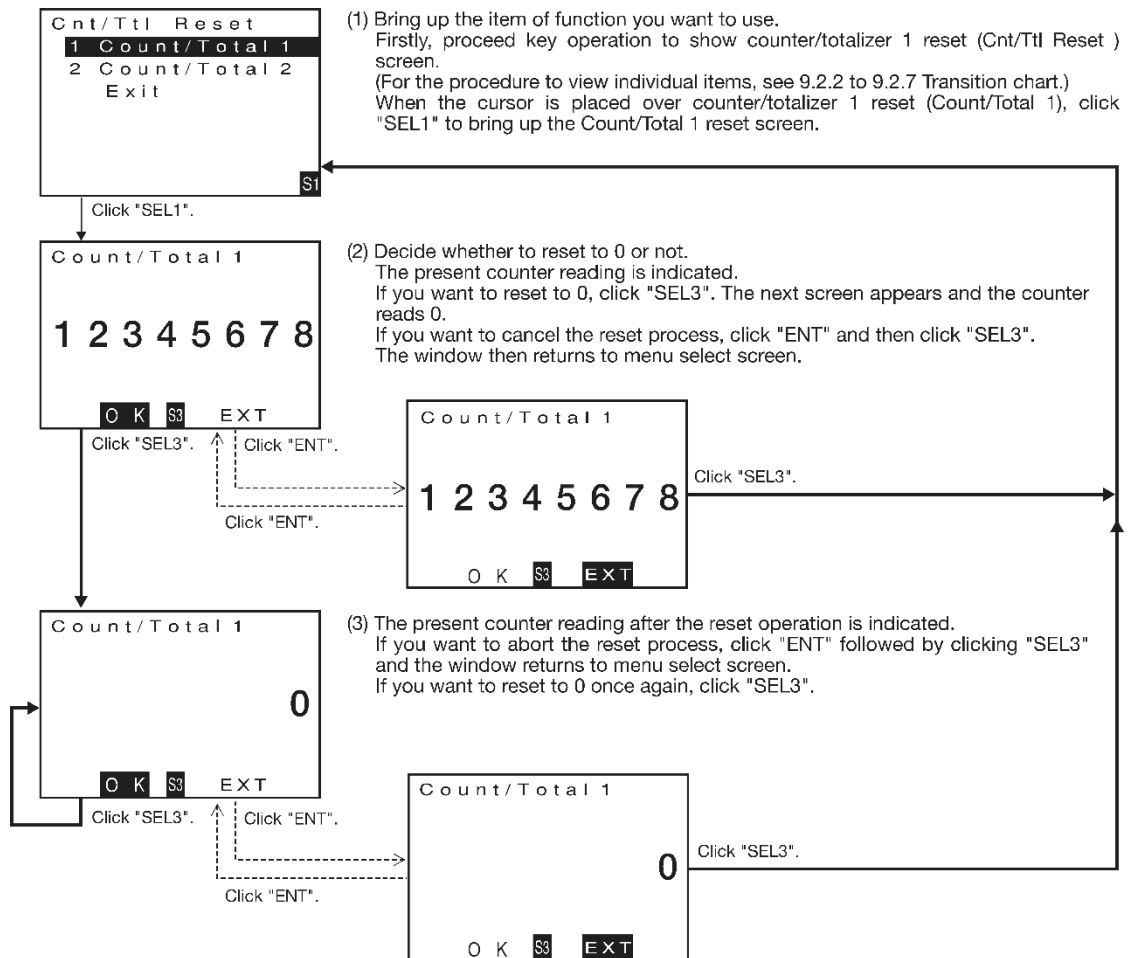

9.11 View Variables Screen Setup

NOTE: For this function, the setting change is disabled in Write Protect mode (refer to section 9.2).

Display / Hide and priority of variables view can be set up at the view variables screen. Follow the procedure outlined below:

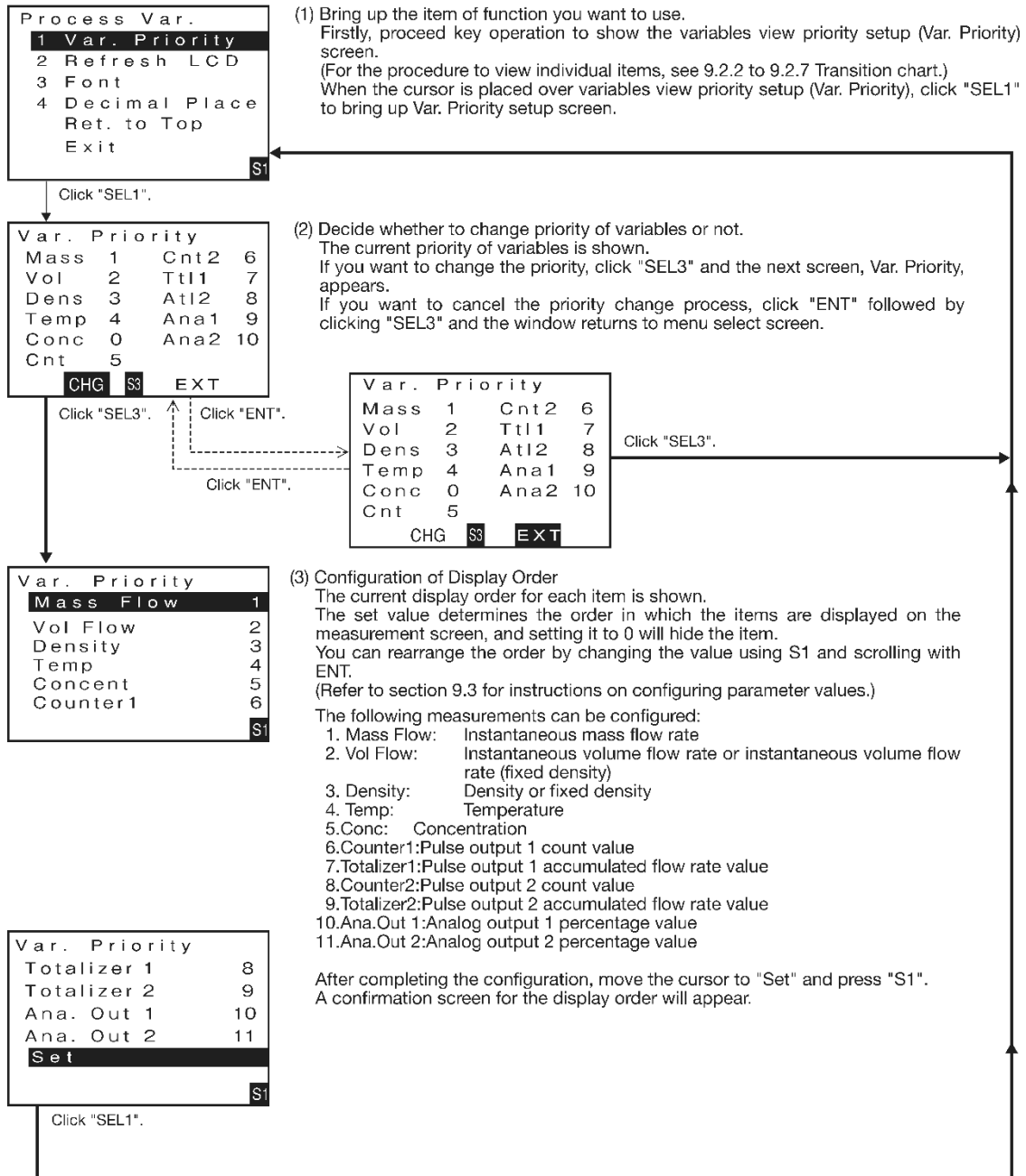

9.12 Pulse Output Function

NOTE: For this function, the setting change is disabled in Write Protect mode (refer to section 9.2).

The transmitter is provided with two pulse outputs which can be set up as independent outputs. Attractive features include a double pulse output created by allowing two pulses out of phase by 90 or 180 degrees, and a bidirectional pulse output - linked with status output signal, enabling the operator to discriminate the direction of flow. Refer to the following topics for description of these features. (NOTE: When the pulse output assignment, full scale flowrate, or frequency at full scale is modified, the Counter/Totalizer will be reset.)

9.12.1 Pulse Output 1

If you want to use pulse output 1, it is required that the following be set up.

For using bidirectional pulse output or double pulse output, be sure to set the assignment of interest.

Setup procedure

① Pulse output 1 assignment (Assign) (See 9.2.4 Transition chart (3) [No. 2-4-3-1].) Kind of flow is selected.

- Mass flow: Mass flow
- Volume flow: Volumetric flow

② Frequency of pulse output 1 at full scale flowrate (Freq Factor) (See 9.2.4 Transition chart (3) [No. 2-4-3-2].)

The frequency at the flowrate set in ③ is set up. Set it to match the measurable range of the instrument that measures pulse output. Acceptable setting range is from 0.1 to 10000Hz.

③ Full scale flowrate of pulse output 1 (Rate Factor) (See 9.2.4 Transition chart (3) [No. 2-4-3-3].) An output is generated at the frequency set in ② when the preset flowrate is reached.

④ Low flow cutoff of pulse output 1 (Lowcut) (See 9.2.4 Transition chart (3) [No. 2-4-3-4].) When the proportion of flowrate is smaller than the low flow cutoff value - where the flowrate set in ③ is set to 100% - the output is clamped at 0. Acceptable setting range is from 0.0 to 10.0%.

⑤ The state of pulse output in an error (Pulse) (See 9.2.5 Transition chart (4) [No. 2-4-6-2].) Pulse output value in an error can be selected from the following three options:

- Zero: Pulse output is halted.
- Hold: Pulse output immediately before an error is maintained.
- Upscale: 11kHz is output. (For detail of output in an error, see 10.1 Error Messages.)

9.12.2 Pulse Output 2

If you want to use pulse output 2, it is required that the following be set up.

For using bidirectional pulse output or double pulse output, be sure to set the assignment of interest.

(In the case of double pulse output, set only pulse output 2 assignment. Invalidating parameters other than that, pulse output 2 is also output with the same setting as that of pulse output 1.)

① Pulse output 2 assignment (Assign) (See 9.2.4 Transition chart(3) [No. 2-4-4-1].) Type of flow to be assigned is selected.

- Mass flow: Mass flow
- Volume flow: Volumetric flow
- Double pulse 90: Double pulse output 90°
- Double pulse -90: Double pulse output - 90°
- Double pulse 180: Double pulse output 180°

As for double pulse output, see 9.12.4 Double pulse output.

As for ②, ③, and ④ below, a procedure similar to pulse output 1 applies. See 9.12.1 Pulse output (1).

② Frequency of pulse output 2 at full scale flowrate (Freq Factor) (See 9.2.4 Transition chart (3) [No. 2-4-4-2].)

③ Full scale flowrate of pulse output 2 (Rate Factor) (See 9.2.4 Transition chart (3) [No. 2-4-4-3].)

④ Low flow cutoff of pulse output 2 (Lowcut) (See 9.2.4 Transition chart (3) [No. 2-4-4-4].)

⑤ The state of pulse output in an error (Pulse) (See 9.2.5 Transition chart (4) [No. 2-4-6-2].)

9.12.3 Bidirectional Pulse Output

By allowing status output signal to provide flow direction information, the transmitter distinguishes between pulse outputs in the forward and reverse flow, and counts up pulses independently. (Hence, it requires on the part of measuring instrument a circuit to distinguish the directions of flow.) To utilize this function, you need to set up the following in addition to settings of pulse outputs 1 and 2.

Setup procedure

① Status output function assignment (Function) (See 9.2.5 Transition chart (4) [No. 2-4-5-1].)

- Select Bi Direction.

② Active output of status output (Mode) (See 9.2.5 Transition chart (4) [No. 2-4-5-3].)

Set the active output status of status output.

- Off Active: Output is in the Short in the forward fluid flow.
- On Active: Output is in the Open in the forward fluid flow.

An example of settings and assignments

- Status output function assignment (Function): Bi Direction
- Active output of status output (Mode): Off Active
- Pulse output 1 assignment (Assign): Mass Flow
- Frequency of pulse output 1 at full scale flowrate (Freq Factor): 1000 [Hz]
- Full scale flowrate of pulse output 1 (Rate Factor): 100.0 [kg/min]
- Low flow cutoff of pulse output 1 (Lowcut): 10.0 [%]

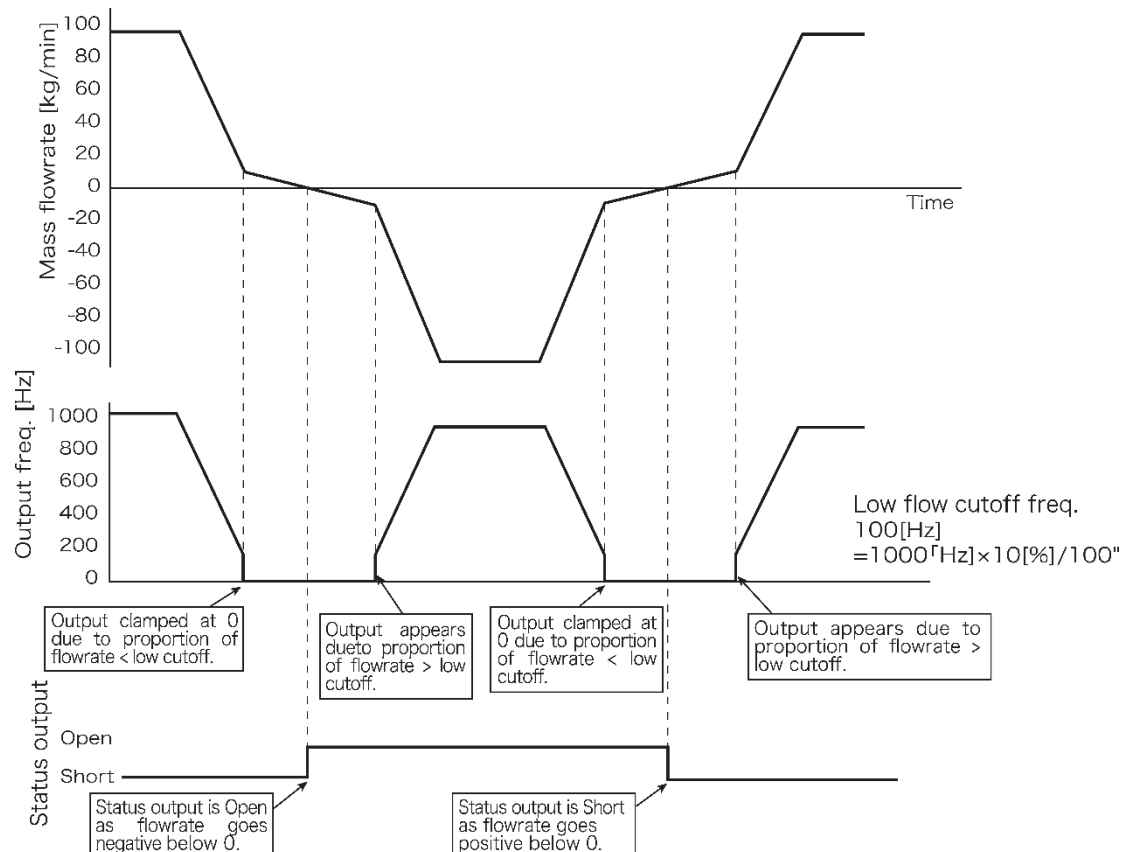

9.12.4 Double Pulse Output

This function provides pulse output 2 in sync with pulse output 1. It is enabled by setting up one of the following to pulse output 2 assignment.

Setup procedure

① Pulse output 2 assignment (Assign)

- Double pulse 90: Double pulse output 90°
Pulse output 2 lags pulse output 1 by 90 degrees (1/4 of the period) when it goes into action. (The maximum lag is 1 ms, above which is a lag within 1/4 of the period, however.)
- Double pulse -90: Double pulse output -90°
Pulse output 1 lags pulse output 2 by 90 degrees (1/4 of the period) when it goes into action. (The maximum lag is 1 ms, above which is a lag within 1/4 of the period, however.)
- Double pulse 180: Double pulse output 180°
Pulse output 2 goes into action, polarity of pulse output 1 waveform inverted.

Examples of setting and behavior

① Double pulse 90°

- Fast pulse output (above 250Hz)

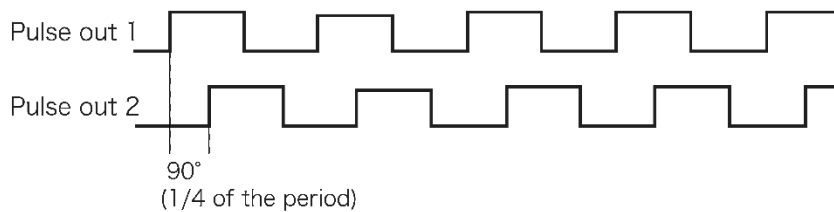

- Slow pulse output (below 250Hz)

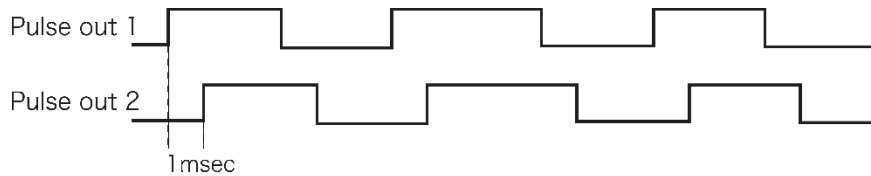

② Double pulse -90°

- Fast pulse output (above 250Hz)

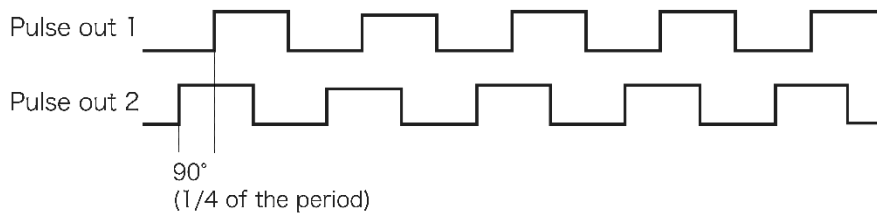

- Slow pulse output (below 250Hz)

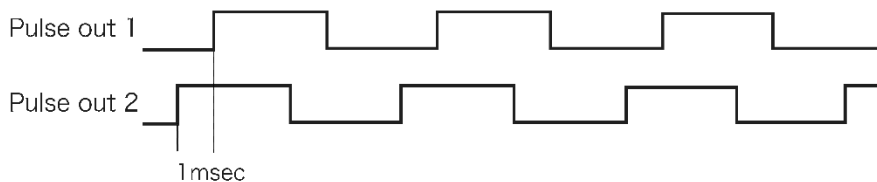

③ Double pulse 180°

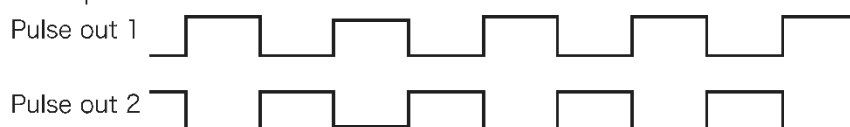

9.13 Analog Output Function

NOTE: For this function, the setting change is disabled in Write Protect mode (refer to section 9.2).

The transmitter is provided with two analog outputs which can be assigned to "mass flow", "volume flow", "temperature", "density" and "drive output". The setup procedure is outlined below:

Setup procedure

By reconfiguring the following five parameters, outputs that suit your particular application are made available.

① Output assignment (Assign) (See 9.2.4 Transition chart (3) [No. 2-4-1-1] and [No. 2-4-2-1].) Types of measurement are selected.

- Mass Flow: Instant mass flowrate
- Vol Flow: Instant volume flowrate
- Density: Density
- Temp: Temperature
- Drive Output: Drive output

When assignments are modified, reconfigure upper limit, lower limit, low flow cutoff, and damping factor to values that best suit your application.

② Upper limit value (URV) (See 9.2.4 Transition chart (3) [No. 2-4-1-2] and [No. 2-4-2-2].)

The lower limit of analog output can be changed; a 4mA output is produced when the preset value is reached. Values outside the maximum range (*1) and smaller than the lower limit value are unacceptable, however.

③ Lower limit value (LRV) (See 9.2.4 Transition chart (3) [No. 2-4-1-3] and [No. 2-4-2-3].) The upper limit of analog output can be changed; a 20mA output is produced when the preset value is reached. Values outside the maximum range (*1) and larger than the upper limit value are unacceptable, however.

④ Low flow cutoff (Lowcut) (See 9.2.4 Transition chart (3) [No. 2-4-1-4] and [No. 2-4-2-4].) The low flow cutoff of analog output (%) can be changed. When the low flow cutoff value is larger than the proportion of analog output – where the upper limit is set to 100% and the lower limit is 0% – the analog output becomes 4mA. Acceptable setting range is from 0% to 10%.

⑤ Damping factor (Added Damp) (See 9.2.4 Transition chart (3) [No. 2-4-1-5] and [No. 2-4-2-5].) Damping constant of analog output (sec) can be changed. Select a larger value when analog output fluctuates excessively; select a smaller value when fast response is desired. Acceptable setting range is from 0 to 200 (sec).

⑥ The state of analog output in an error (Analog) (See 9.2.5 Transition chart (5) [No. 2-4-6-1].)

- Downscale: 2.4mA is output.
- Zero: 4mA is output.
- Hold: Analog output immediately before an error is maintained.
- Upscale: 21.6mA is output.
(For details of outputs in an error, see 10.1 Error Messages.)

*1 Maximum range

- Instant mass flowrate: – Max allowable range to max allowable range
- Instant volume flowrate: – Max allowable range/0.3 to max allowable range/0.3
- Temperature: Max temperature range of sensor
- Density: 0.0 to 5.0

CAUTION:

When measurement-related unit set up at Assign is modified, the upper and lower limit values will be converted automatically to the measures to read in the unit selected.

9.14 Status Output

NOTE: For this function, the setting change is disabled in Write Protect mode (refer to section 9.2).

One output chosen from status information, flow direction, and alarm state can be assigned to the status output.

For details of individual functions, refer to the respective items below:

9.14.1 Status Output (Error Status)

By assigning the output of status information to the status output, the state of the flowmeter of interest can be output. Listed below are user assignable flowmeter-related items that can be set up and configured individually.

- Sensor error (Sensor Failure)
 - Transmitter error (Txr Failure)
 - Calibration error (Calibration Failure)
 - Consent alarm (Concentration Alarm)
 - Output error (Saturated Alarm)
 - Parameter alarm (Parameter Alarm)
 - Transmitter alarm (Transmitter Alarm)
 - Slug flow alarm (Slug Alarm)
 - Calibration in progress (Cal in Progress)
 - Simulated output being produced (Fix Output)
- (For details, see 10.1 Error Messages and 10.2 Status Messages.)

Operating procedure

- Select "Error Status" in selecting the status output function assignment. (See 9.2.5 Transition chart (4) [No. 2-4-5-1].)
- The flowmeter-related states listed above are available for an output; set up each item to either on or off. (See 9.2.5 Transition chart (4) [No. 2-4-5-2-1] to [No. 2-4-5-2-9].)
- Set up the active output of status output. According to the settings, the following outputs become available.
With setting "On Active", the output is Short when the preset state is reached. With setting "Off Active", the output is Open when the preset state is reached. (See 9.2.5 Transition chart (4) [No. 2-4-5-4].)

When the settings above take effect, the functions are ready for use.

9.14.2 Bidirectional Flow Direction Output (Bi Direction)

By selecting the bidirectional output for status output, an output representing the flow direction becomes available.

Pulse output is normally available in the forward direction, but with the bidirectional output setup, pulse output in the reverse direction is also available. (For details, see 9.12.3 Bidirectional pulse output.)

Operating procedure

- Select "Bi Direction" in selecting the status output function assignment. (See 9.2.5 Transition chart (4) [No. 2-4-5-1].)
- Set the active output of status output. According to the settings, the following outputs become available.

With setting "On Active", the output is Short when the fluid flows in the reverse direction. With setting "Off Active", the output is Open when the fluid flows in the reverse direction. (See 9.2.5 Transition chart (4) [No. 2-4-5-4].)

When the settings above take effect, the functions are ready for use.

9.14.3 H/L Alarm Output (H/L Alarm)

By assigning the high/low alarm output to the status output, an error output of high/low alarm of interest can be provided. Listed below are available variables that can be set up.

- Mass Flow: Instant mass flowrate
 - Vol Flow: Instant volume flowrate
 - Dens: Density
 - Temp: Temperature
 - Counter 1: Counter 1
 - Counter 2: Counter 2
- (For details of high/low alarms, see 9.16 High/Low Alarm Functions.)

Operating procedure

- Select "H/L Alarm" in selecting the status output function assignment; the state of high/low alarm can then be output. (See 9.2.5 Transition chart (4) [No. 2-4-5-1].)
- Set the output of status output. According to the settings, the following outputs become available

With setting "On Active", the output is in the Short in an alarmed condition of high/low alarms.

With setting "Off Active", the output is in the Open in an alarmed condition of high/low alarms. (See 9.2.5 Transition chart (4) [No. 2-4-5-4].)

When the settings above take effect, the functions are ready for use.

9.14.4 Drive Output Alarm (Used for Maintenance Purpose)

By assigning the drive output alarm to status output, the alarm can be activated when the drive output exceeds the threshold.

Operating procedure

- Select "Drive O Alm." for the status output function assignment; the state of drive output can then be output. (See 9.2.5 Transition chart (4) [No. 2-4-5-1])
- Enter the threshold to determine at what percentage of the drive output the alarm output should be activated. The initial value is 100%. (See 9.2.5 Transition chart (4) [No. 2-4-5-3])
- Set the output of status output. When this setting takes effect, the following status output appears.
With setting "On Active", the output is always in the Short.
With setting "Off Active", the output is always in the Open. (See 9.2.5 Transition chart (4) [No. 2-4-5-4])
The function becomes available by setting the above.

9.14.5 No Assignment (No Function)

When this setting takes effect, the following status output appears. With setting "On Active", the output is always in the Short. With setting "Off Active", the output is always in the Open.

Operating procedure

- Select "No Function" in selecting the status output function assignment. (See 9.2.5 Transition chart (4) [No. 2-4-5-1].)

9.15 Status Input Function

NOTE: For this function, the setting change is disabled in Write Protect mode (refer to section 9.2).

One of "pulse/analog output fixed to 0%", "zeroing", "totalizer 1 and totalizer 2 reset", "totalizer 1 reset", or "totalizer 2 reset" can be assigned to the status input.

For details of individual functions, refer to the respective items below.

9.15.1 Pulse/Analog Output fixed to 0% (0% Sig Lock)

When an input arrives across status input terminals, pulse output and analog output are fixed to 0Hz and 0mA, respectively.

Stopping an input across status input terminals cancels fixing of the output.

Operating procedure

- Select "0% Sig Lock" in selecting the status input function assignment. (See 9.2.5 Transition chart (4) [No. 2 to 5-1].)
- Set the input mode of status input. According to the settings, the following input mode will be enabled:
"Short Active" setting: the function is activated 0.3 seconds after the condition of the circuit between status input terminals is changed from opened to shorted.
"Open Active" setting: the function is activated 0.3 seconds after the condition of the circuit between status input terminals is changed from shorted to opened. (See 9.2.5 Transition chart (4) [No.2-5-2])
The function becomes available by setting the above.

9.15.2 Zero Adjustment (Auto Zero)

When an input arrives across status input terminals, automatic zero is initiated to reduce offset flowrate drift to minimum.

(For detail of the function, see "9.8 Zeroing Function".)

Operating procedure

- Select "Auto Zero" in selecting the status input function assignment. (See 9.2.5 Transition chart (4) [No. 2-5-1].)
- Set the input mode of status input. According to the settings, the following input mode will be enabled:
"Short Active" setting: the function is activated 0.3 seconds after the condition of the circuit between status input terminals is changed from opened to shorted.
"Open Active" setting: the function is activated 0.3 seconds after the condition of the circuit between status input terminals is changed from shorted to opened.
(See 9.2.5 Transition chart (4) [No.2 to 5-2])
The function becomes available by setting the above.

9.15.3 Totalizer 1 and Totalizer 2 Reset (Reset Total 1 and 2)

The transmitter is provided with counters (Counters 1 and 2) and totalizers (Totalizers 1 and 2) which work in synchronism with pulse output. When an input arrives across status input terminals, all these counters – Counters 1 and 2 and Totalizers 1 and 2 – are reset to 0.

In this connection, counter 1 and totalizer 1 respond to pulse 1 output while counter 2 and totalizer 2 respond to pulse 2. (For detail of the function, see 9.10 Reset Function.)

Operating procedure

- Select "Reset C/T 1·2" in selecting the status input function assignment. (See 9.2.5 Transition chart (4) [No. 2-5-1].)
- Set the input mode of status input. According to the settings, the following input mode will be enabled:
"Short Active" setting: the function is activated 0.3 seconds after the condition of the circuit between status input terminals is changed from opened to shorted.
"Open Active" setting: the function is activated 0.3 seconds after the condition of

the circuit between status input terminals is changed from shorted to opened.

(See 9.2.5 Transition chart (4) [No.2 to 5-2])
The function becomes available by setting the above.

9.15.4 Totalizer 1 Reset (Reset Total 1)

The transmitter is provided with counters (Counters 1 and 2) and totalizers (Totalizers 1 and 2) which work in synchronism with pulse output. When an input arrives across status input terminals, counter 1 and totalizer 1 are reset to 0.

In this connection, counter 1 and totalizer 1 respond to pulse 1 output while counter 2 and totalizer 2 respond to pulse 2. (For detail of the function, see 9.10 Reset Functions.)

Operating procedure

- Select "Reset D/T 1" in selecting the status input function assignment. (See 9.2.5 Transition chart (4) [No. 2 to 5-1].)
- Set the input mode of status input. According to the settings, the following input mode will be enabled:
"Short Active" setting: the function is activated 0.3 seconds after the condition of the circuit between status input terminals is changed from opened to shorted.
"Open Active" setting: the function is activated 0.3 seconds after the condition of the circuit between status input terminals is changed from shorted to opened.
(See 9.2.5 Transition chart (4) [No.2 to 5-2])
The function becomes available by setting the above.

9.15.5 Totalizer 2 Reset (Reset Total 2)

The transmitter is provided with counters (Counters 1 and 2) and totalizers (Totalizers 1 and 2) which work in synchronism with pulse output. When an input arrives across status input terminals, counter 2 and totalizer 2 are reset to 0.

In this connection, counter 1 and totalizer 1 respond to pulse 1 output while counter 2 and totalizer 2 respond to pulse 2. (For detail of the function, see 9.10 Reset Function.)

Operating procedure

- Select "Reset C/T 2" in selecting the status input function assignment. (See 9.2.5 Transition chart (4) [No. 2 to 5-1].)

- Set the input mode of status input. According to the settings, the following input mode will be enabled:
"Short Active" setting: the function is activated 0.3 seconds after the condition of the circuit between status input terminals is changed from opened to shorted.
"Open Active" setting: the function is activated 0.3 seconds after the condition of the circuit between status input terminals is changed from shorted to opened.
(See 9.2.5 Transition chart (4) [No.2 to 5-2])
The function becomes available by setting the above.

9.16 High/Low Alarm Function

NOTE: For this function, the setting change is disabled in Write Protect mode (refer to section 9.2).

The transmitter provides the operator with quick grasp of conditions of the installation – flowrate, temperature, density and total flow – when high/low alarms are set up. In the event the preset alarm conditions are met, it tells the operator the event with an alarm message along with a status output signal. Setup procedure and behavior of alarm functions are described below:

Setup procedure

Ensure positive settings on individual items.

- ① Status output function assignment (Function) (See 9.2.5 Transition chart (4) [No. 2-4-5-1].) To use high/low alarm function, it is essential to assign high/low alarms to status output.
Set "H/L Alarm" to status output function assignment. ("H/L Alarm" setting is required even in cases of high alarm only or low alarm only.)
- ② Output mode of status output (Mode) (See 9.2.5 Transition chart (4) [No. 2-4-5-3].) Set up the output mode of status output.
 - Active output of status output: Off Active or On Active
(For detail of the status output function, see 9.14 Status Output Function.)

③ Assignment of H/L alarm values (Assign) (See 9.2.5 Transition chart (4) [No. 2-6-1].)
From the following options, select the variables against which the transmitter identifies alarmed conditions.

- Mass Flow: Instant mass flowrate
- Vol Flow: Instant volume flowrate
- Dens: Density
- Temp: Temperature
- Counter 1: Counter 1
- Counter 2: Counter 2

④ Alarm type selection (H/L Alm. Type) (See 9.2.5 Transition chart (4) [No. 2-6-2].)

Select alarm type from the following options.

- To validate only high alarm, select "High Alarm".
- To validate only low alarm, select "Low Alarm".
- To validate both high and low alarms, select "H/L Alarm".

⑤ High alarm value setting (High Alm. Po.) (See 9.2.5 Transition chart (4) [No. 2-6-3].)
If the input exceeds this setting, the high alarm is activated. Set the high alarm value desired. In the case "Low Alarm" is set in ④, setting is not required.

⑥ Low alarm value setting (Low Alm. Po.) (See 9.2.5 Transition chart (4) [No. 2-6-4].)

- Low Alm. Po.: Low alarm value

In the case "High Alarm" is set in ④, setting is not required.

⑦ Hysteresis value setting for high/low alarms (H/L Alm. hys) (See 9.2.5 Transition chart (4) [No. 2-6-5].)
The setting determines a dead (or immunity) zone following the occurrence of an alarm. Select a larger value when measurement fluctuates excessively; select a smaller value if fast recovery from alarmed condition is desired.

(2) An example of settings and assignments:

- Status output assignment (Function): H/L Alarm
- Active output of status output (Mode): Off Active
- H/L alarm value assignment (Assign): Mass Flow
- Alarm type selection (H/L Alm. Type): H/L Alarm
- High alarm value setting (High Alm. Po.): 900 [kg/min]
- Low alarm value setting (Low Alm. Po.): 200 [kg/min]
- High/low alarm hysteresis value setting (H/L Alm. hys): 100 [kg/min]

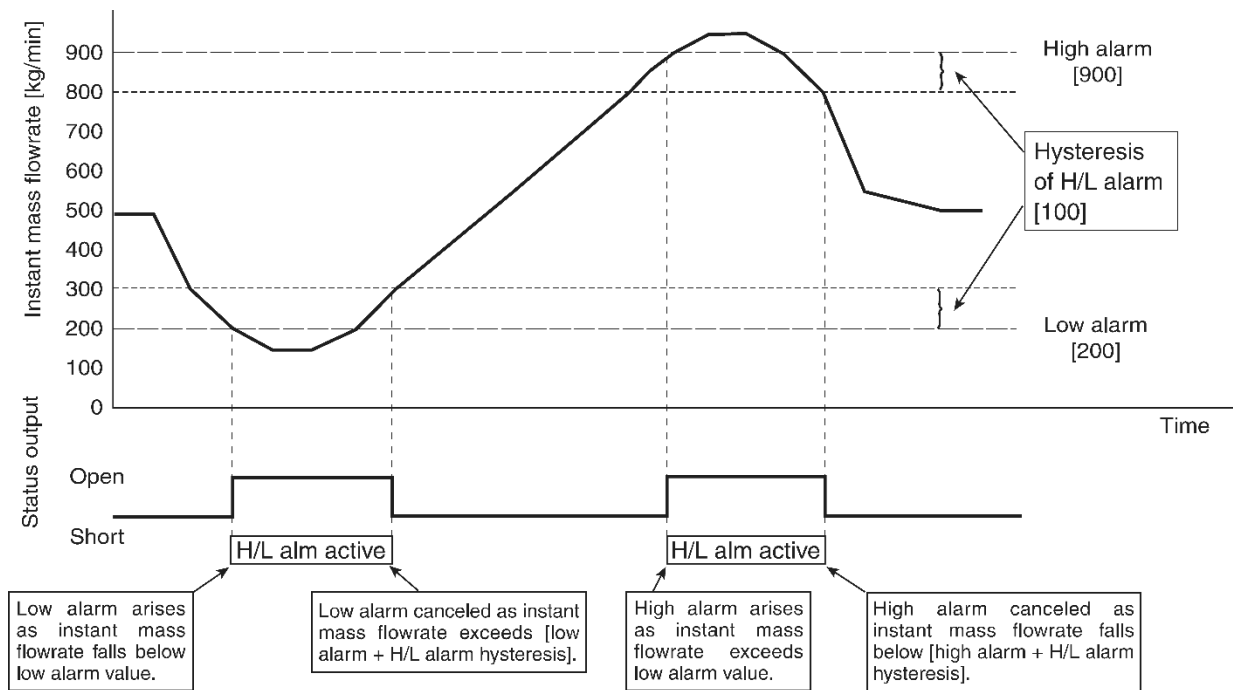

9.17 Gas Mixed Flow Alarm Function

NOTE: For this function, the setting change is disabled in Write Protect mode (refer to section 9.2).

If gases exist in large quantities in the process fluid, it is impossible to make accurate flow measurement. This feature, if correctly set up, detects gases entrapped in the fluid, indicates a slug flow alarm, clamps the flow signal at 0, and provides a status output telling the operator the alarm event. (If you want to use this function, set the higher limit density value of slug flow to 10 (default) and the lower limit density value of slug flow to 0 (default). This function then remains disabled.) The setup procedure of slug flow function is outlined below.

Setup procedure

Ensure positive settings of individual items.

① Lower limit density of slug flow (Slug Low) (See 9.2.3 Transition chart (2) [No. 2-2-3].) Upon detection of density smaller than this setting, the circuitry interprets it as slug flow and starts analysis.

Set a value small enough with respect to the density expected for the fluid of interest.

② Higher limit density of slug flow (Slug High) (See 9.2.4 Transition chart (2) [No. 2-2-4].) Upon detection of density larger than this setting, the circuitry interprets it as an error and starts analysis.

Set a value large enough with respect to the density expected for the fluid of interest.

③ Slug flow identification time (Slug Duration) (See 9.2.5 Transition chart (2) [No. 2-2-5].)

It is the time required for the circuitry to identify the slug flow being outside the slug flow high/low limit and to issue a slug flow alarm (sec). Until this slug flow identification time expires, it retains the most recent and properly measured value. After the expiration of this preset time, the flowrate becomes 0.

④ If you want to assign this slug flow alarm in the status output function to the status output, setting the following is required: (For detail of this output function, see 9.14 Status Output Function.)

- Status output function assignment: Error Status (See 9.2.5 Transition chart (2) [No. 2-4-5-1].)
- Slug flow error select: On (See 9.2.5 Transition chart (4) [No. 2-4-5-2-7].)
- Active output of status output: Off Active or On Active (See 9.2.5 Transition chart (4) [No. 2-4-5-3].)

An example of settings and behavior

- Lower limit density value of slug flow: 0.5 [g/mL]
- Upper limit density value of slug flow: 2.0 [g/mL]
- Slug flow identification time: 10 [sec]

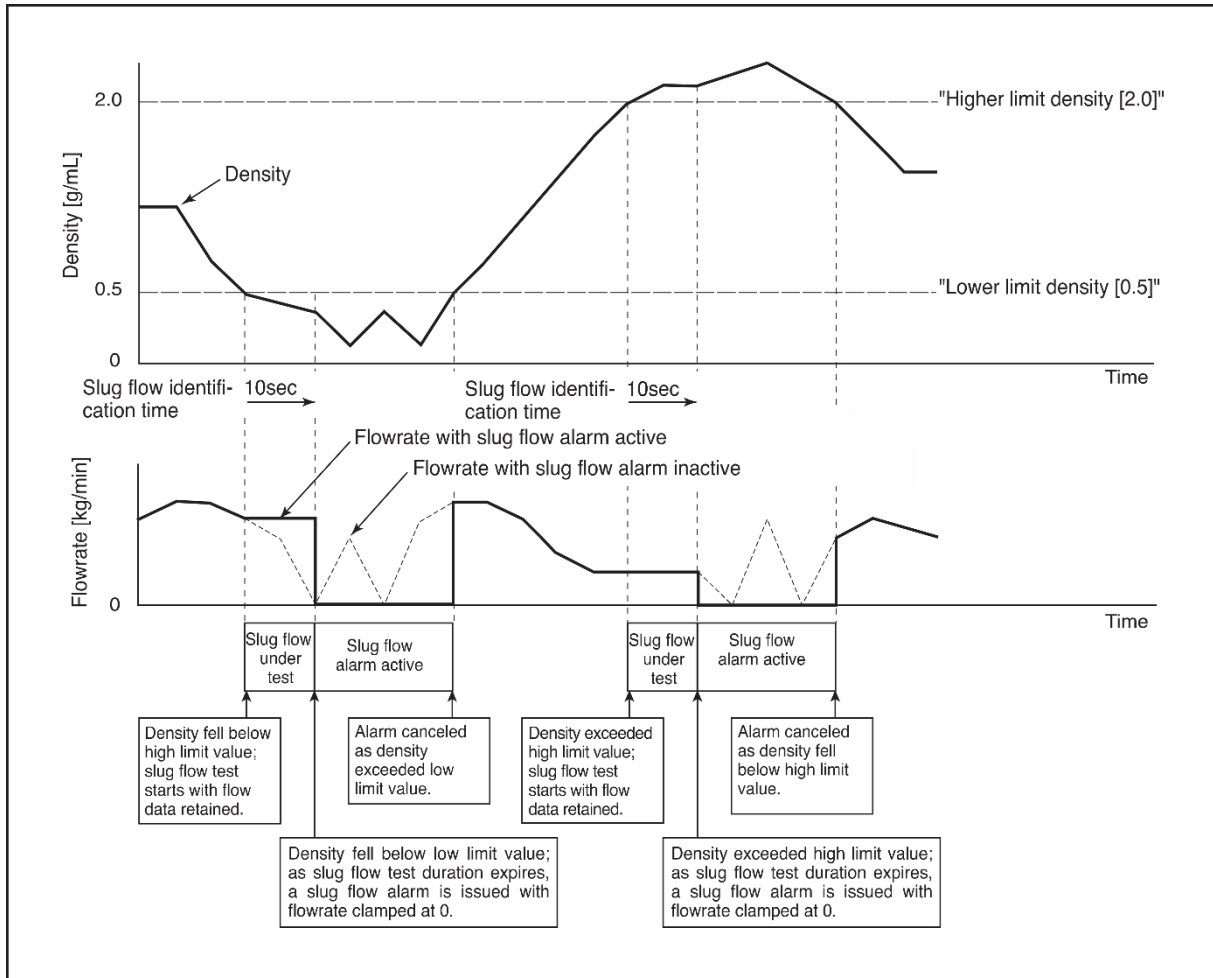

9.18 Setup Unit List

Measurement type	No.	Acceptable setup units	LCD display
Instantaneous mass flowrate	M-1	g/sec	g/s
	M-2	g/min	g/min
	M-3	g/hr	g/h
	M-4	kg/sec	kg/s
	M-5	kg/min	kg/min
	M-6	kg/hr	kg/h
	M-7	kg/day	kg/d
	M-8	MetTon/min	Mt/min
	M-9	MetTon/hr	Mt/h
	M-10	MetTon/day	Mt/d
	M-11	lb/sec	lb/s
	M-12	lb/min	lb/min
	M-13	lb/hr	lb/h
	M-14	lb/day	lb/d
	M-15	ShTon/min	St/min
	M-16	ShTon/hr	St/h
	M-17	ShTon/day	St/d
Instantaneous volume flowrate	V-1	ml/sec	mL/s
	V-2	ml/min	mL/min
	V-3	ml/hr	mL/h
	V-4	liter/sec	L/s
	V-5	liter/min	L/min
	V-6	liter/hr	L/h
	V-7	liter/day	L/d
	V-8	CuMtr/sec	Cm/s
	V-9	CuMtr/min	Cm/min
	V-10	CuMtr/hr	Cm/h
	V-11	CuMtr/day	Cm/d
	V-12	gal/sec	ga/s
	V-13	gal/min	ga/min
	V-14	ImpGal/min	Ig/min
	V-15	ImpGal/hr	Ig/h
	V-16	ImpGal/day	Ig/d
	V-17	CuFt/sec	Cf/s
	V-18	CuFt/min	Cf/min
	V-19	CuFt/hr	Cf/h
	V-20	bbbl/sec	bl/s
	V-21	bbbl/min	bl/min
	V-22	bbbl/hr	bl/h
	V-23	bbbl/day	bl/d
Density	D-1	g/ml	g/mL
	D-2	g/cc	g/cc
	D-3	kg/l	kg/L
	D-4	kg/CuMtr	kg/Cum
	D-5	lb/gal	lb/gal
	D-6	lb/CuFt	lb/Cf
	D-7	SGU	SGU
Temperature	T-1	°C	deg C
	T-2	°F	deg F
	T-3	Kelvin	Kelvin
	T-4	°R	deg R

Implemented Bell 202 command list

10 Bell 202 command list

Following table shows the implemented Bell 202 command list.

Command			Request Data				Response Data				Response Code
No.	Description	Type	Size	Byte	Name	Format	Size	Byte	Name	Format	
0	Read Unique Identifier	R	-				22	0	"254"	Unsigned-8	0
								1	Manufacturer Identification Code	Unsigned-8	
								2	Manufacturer's Device Type Code	Unsigned-8	
								3	Number of Preambles Master to Slave	Unsigned-8	
								4	HART Protocol Major Revision	Unsigned-8	
								5	Device Revision	Unsigned-8	
								6	Software Revision	Unsigned-8	
								7	Hardware Revision	Unsigned-8	
								7-3			
								7	Physical Signaling Code	Unsigned-8	
								2-0			
								8	Flags	Unsigned-8	
								9-11	Device ID	Unsigned-24	
								12	Minimum number of preambles to be sent with the response message	Unsigned-8	
13	Maximum Number of Device Variables	Unsigned-8									
14	Configuration Change Counter 0	Unsigned-8									
15	Configuration Change Counter 1	Unsigned-8									
16	Extended Field Device Status	Unsigned-8									
17	Manufacturer Identification Code 0	Unsigned-8									
18	Manufacturer Identification Code 1	Unsigned-8									
19	Private Label Distributor Code 0	Unsigned-8									
20	Private Label Distributor Code 1	Unsigned-8									
21	Device Profile	Unsigned-8									
1	Read Primary Variable	R	-				5	0	PV Units Code	Unsigned-8	0
								1-4	PV	Float	
2	Read Loop Current and Percent of Range	R	-				8	0-3	PV Loop Current	Float	0
								4-7	PV Percent of Range	Float	
3	Read Dynamic Variables and Loop Current	R	-				24	0-3	PV Loop Current	Float	0,1,5
								4	PV Units Code	Unsigned-8	
								5-8	PV	Float	
								9	SV Units Code	Unsigned-8	
								10-13	SV	Float	
								14	TV Units Code	Unsigned-8	
								15-18	TV	Float	
								19	QV Units Code	Unsigned-8	
20-23	QV	Float									
6	Write Polling Address	W	2	0	Polling Address of Device	Unsigned-8	2	0	Polling Address of Device	Unsigned-8	0,2,5,12,1,7,32
				1	Loop Current Mode	Unsigned-8		1	Loop Current Mode	Unsigned-8	
7	Read Loop Configuration	R	-				2	0	Polling Address of Device	Unsigned-8	0
								1	Loop Current Mode	Unsigned-8	

Command			Request Data				Response Data				Response Code
No.	Description	Type	Size	Byte	Name	Format	Size	Byte	Name	Format	
8	Read Dynamic Variable Classification	R	-				4	0	Primary Variable Classification	Unsigned-8	0
								1	Secondary Variable Classification	Unsigned-8	
								2	Tertiary Variable Classification	Unsigned-8	
								3	Quaternary Variable Classification	Unsigned-8	
9	Read Dynamic Variable Classification	R	4				37	0	Slot 0: Device Variable Code	Unsigned-8	0,2,5,30
								1	Slot 1: Device Variable Code	Unsigned-8	
								2	Slot 2: Device Variable Code	Unsigned-8	
								3	Slot 3: Device Variable Code	Unsigned-8	
								0	Extended Field Device Status	Unsigned-8	
								1	Slot 0: Device Variable Code	Unsigned-8	
								2	Slot 0: Device Variable Classification	Unsigned-8	
								3	Slot 0: Units Code	Unsigned-8	
								4-7	Slot 0: Device Variable Value	Float	
								8	Slot 0: Device Variable Status	Unsigned-8	
								9	Slot 1: Device Variable Code	Unsigned-8	
								10	Slot 1: Device Variable Classification	Unsigned-8	
								11	Slot 1: Units Code	Unsigned-8	
								12-15	Slot 1: Device Variable Value	Float	
								16	Slot 1: Device Variable Status	Unsigned-8	
								17	Slot 2: Device Variable Code	Unsigned-8	
								18	Slot 2: Device Variable Classification	Unsigned-8	
								19	Slot 2: Units Code	Unsigned-8	
								20-23	Slot 2: Device Variable Value	Float	
								24	Slot 2: Device Variable Status	Unsigned-8	
25	Slot 3: Device Variable Code	Unsigned-8									
26	Slot 3: Device Variable Classification	Unsigned-8									
27	Slot 3: Units Code	Float									
28-31	Slot 3: Device Variable Value	Float									
32	Slot 3: Device Variable Status	Float									
33-36	Slot 0 data time stamp	Float									

Command			Request Data				Response Data				Response Code
No.	Description	Type	Size	Byte	Name	Format	Size	Byte	Name	Format	
11	Read Unique Identifier Associated with Tag	R	6	0-5	Tag (Dummy)	Packed ASCII	22	0	"254"	Unsigned-8	0
								1	Manufacturer Identification Code	Unsigned-8	
								2	Manufacturer's Device Type Code	Unsigned-8	
								3	Number of Preambles Master to Slave	Unsigned-8	
								4	HART Protocol Major Revision	Unsigned-8	
								5	Device Revision	Unsigned-8	
								6	Software Revision	Unsigned-8	
								7	Hardware Revision	Unsigned-8	
								7			
								2-0	Physical Signaling Code	Unsigned-8	
								8	Flags	Unsigned-8	
								9-11	Device ID	Unsigned-24	
								12	Minimum number of preambles to be sent with the response message	Unsigned-8	
								13	Maximum Number of Device Variables	Unsigned-8	
								14	Configuration Change Counter 0	Unsigned-8	
								15	Configuration Change Counter 1	Unsigned-8	
								16	Extended Field Device Status	Unsigned-8	
								17	Manufacturer Identification Code 0	Unsigned-8	
								18	Manufacturer Identification Code 1	Unsigned-8	
								19	Private Label Distributor Code 0	Unsigned-8	
								20	Private Label Distributor Code 1	Unsigned-8	
				21	Device Profile	Unsigned-8					
12	Read Message	R	-				24	0-23	Message	Packed ASCII	0
13	Read Tag, Descriptor, Date	R	-				21	0-5	Tag	Packed ASCII	0
								6-17	Descriptor	Packed ASCII	
								18	Day	Unsigned-8	
								19	Month	Unsigned-8	
								20	Year	Unsigned-8	
14	Read PV Transducer Information	R	-				16	0-2	Transducer Serial No.	Unsigned-24	0
								3	Transducer Limit, Min Span Units Codes	Unsigned-8	
								4-7	Upper Transducer Limit	Float	
								8-11	Lower Transducer Limit	Float	
								12-15	Minimum Span	Float	
15	Read Device Information	R	-				18	0	PV Alarm Selection Code	Unsigned-8	0
								1	PV Transfer Function Code	Unsigned-8	
								2	PV Upper, Lower Range Values Units Code	Unsigned-8	
								3-6	PV Upper Range Value	Float	
								7-10	PV Lower Range Value	Float	
								11-14	PV Damping Value	Float	
								15	Write Protect Code	Unsigned-8	
								16	"250"	Unsigned-8	
17	PV Analog Channel Flags	Unsigned-8									
16	Read Final Assembly Number	R	-				3	0-2	Final Assembly Number	Unsigned-24	0

Command			Request Data				Response Data				Response Code
No.	Description	Type	Size	Byte	Name	Format	Size	Byte	Name	Format	
17	Write Message	W	24	0-23	Message	Packed ASCII	24	0-23	Message	Packed ASCII	0,1,5,7,32
18	Write Tag, Descriptor, Date	W	21	0-5	Tag	Packed ASCII	21	0-5	Tag	Packed ASCII	0,9,1,5,7,32
				6-17	Descriptor	Packed ASCII		6-17	Descriptor	Packed ASCII	
				18	Day	Unsigned-8		18	Day	Unsigned-8	
				19	Month	Unsigned-8		19	Month	Unsigned-8	
				20	Year	Unsigned-8		20	Year	Unsigned-8	
19	Write Final Assembly Number	W	3	0-2	Final Assembly Number	Unsigned-24	3	0-2	Final Assembly Number	Unsigned-24	0,1,5,7,32
20	Read Long Tag	R	-				32	0-31	Long Tag	Packed ASCII	0
21	Read Unique Identifier Associated with Long Tag	R	32	0-31	Long Tag (Dummy)	Packed ASCII	22	0	"254"	Unsigned-8	0
								1	Manufacturer Identification Code	Unsigned-8	
								2	Manufacturer's Device Type Code	Unsigned-8	
								3	Number of Preambles Master to Slave	Unsigned-8	
								4	HART Protocol Major Revision	Unsigned-8	
								5	Device Revision	Unsigned-8	
								6	Software Revision	Unsigned-8	
								7	Hardware Revision	Unsigned-8	
								7-3			
								7	Physical Signaling Code	Unsigned-8	
								7-0	Flags	Unsigned-8	
								8	Device ID	Unsigned-24	
								9-11	Minimum number of preambles to be sent with the response message	Unsigned-8	
								12	Maximum Number of Device Variables	Unsigned-8	
								13	Configuration Change Counter 0	Unsigned-8	
								14	Configuration Change Counter 1	Unsigned-8	
								15	Extended Field Device Status	Unsigned-8	
								16	Manufacturer Identification Code 0	Unsigned-8	
								17	Manufacturer Identification Code 1	Unsigned-8	
								18	Private Label Distributor Code 0	Unsigned-8	
								19	Private Label Distributor Code 1	Unsigned-8	
								20	Device Profile	Unsigned-8	
22	Write Long Tag	W	32	0-31	Long Tag	Packed ASCII	32	0-31	Long Tag	Packed ASCII	0,1,5,7,32
33	Read Device Variables	R	4	0	Slot 0: Device Variable Code	Unsigned-8	24	0	Slot 0: Device Variable Code	Unsigned-8	0,2,5
				1	Slot 1: Device Variable Code	Unsigned-8		1	Slot 0: Units Code	Unsigned-8	
				2	Slot 2: Device Variable Code	Unsigned-8		2-5	Slot 0: Device Variable Value	Float	
				3	Slot 3: Device Variable Code	Unsigned-8		6	Slot 1: Device Variable Code	Unsigned-8	
								7	Slot 1: Units Code	Unsigned-8	
								8-11	Slot 1: Device Variable Value	Float	
								12	Slot 2: Device Variable Code	Unsigned-8	
								13	Slot 2: Units Code	Unsigned-8	
								14-17	Slot 2: Device Variable Value	Float	
								18	Slot 3: Device Variable Code	Unsigned-8	
								19	Slot 3: Units Code	Unsigned-8	
								20-23	Slot 3: Device Variable Value	Float	

10 Bell 202 command list

Command			Request Data				Response Data				Response Code
No.	Description	Type	Size	Byte	Name	Format	Size	Byte	Name	Format	
35	Write Primary Variable Range Values	W	9	0	Upper and Lower Range Values Units Code	Unsigned-8	9	0	Upper and Lower Range Values Units Code	Unsigned-8	0,18,6,8,9,10,11,12,13,14,29,5,7,32
				1-4	Upper Range Value	Float		1-4	Upper Range Value	Float	
				5-8	Lower Range Value	Float		5-8	Lower Range Value	Float	
38	Reset Configuration Changed Flag	C	2	0-1	Configuration Change Counter	Unsigned-16	2	0-1	Configuration Change Counter	Unsigned-16	0,5,9
41	Perform Self-Test	C	-				-				0
42	Perform Device Reset	C	-				-				0
43	Set PV Zero	C	-				-				0,9,10,7,32
48	Read Additional Device Status	R	25	0	Device-Specific Status 0	Unsigned-8	25	0	Device-Specific Status 0	Unsigned-8	0,5
				1	Device-Specific Status 1	Unsigned-8		1	Device-Specific Status 1	Unsigned-8	
				2	Device-Specific Status 2	Unsigned-8		2	Device-Specific Status 2	Unsigned-8	
				3	Device-Specific Status 3	Unsigned-8		3	Device-Specific Status 3	Unsigned-8	
				4	Device-Specific Status 4	Unsigned-8		4	Device-Specific Status 4	Unsigned-8	
				5	Device-Specific Status 5	Unsigned-8		5	Device-Specific Status 5	Unsigned-8	
				6	Extend Device Status Information	Unsigned-8		6	Extend Device Status Information	Unsigned-8	
				7	Operating Mode	Unsigned-8		7	Operating Mode	Unsigned-8	
				8	Standardized Status 0	Unsigned-8		8	Standardized Status 0	Unsigned-8	
				9	Standardized Status 1	Unsigned-8		9	Standardized Status 1	Unsigned-8	
				10	Analog Channel Saturated	Unsigned-8		10	Analog Channel Saturated	Unsigned-8	
				11	Standardized Status 2	Unsigned-8		11	Standardized Status 2	Unsigned-8	
				12	Standardized Status 3	Unsigned-8		12	Standardized Status 3	Unsigned-8	
				13	Analog Channel Fixed	Unsigned-8		13	Analog Channel Fixed	Unsigned-8	
				14	Device-Specific Status 6	Unsigned-8		14	Device-Specific Status 6	Unsigned-8	
				15	Device-Specific Status 7	Unsigned-8		15	Device-Specific Status 7	Unsigned-8	
				16	Device-Specific Status 8	Unsigned-8		16	Device-Specific Status 8	Unsigned-8	
				17	Device-Specific Status 9	Unsigned-8		17	Device-Specific Status 9	Unsigned-8	
				18	Device-Specific Status 10	Unsigned-8		18	Device-Specific Status 10	Unsigned-8	
				19	Device-Specific Status 11	Unsigned-8		19	Device-Specific Status 11	Unsigned-8	
				20	Device-Specific Status 12	Unsigned-8		20	Device-Specific Status 12	Unsigned-8	
				21	Device-Specific Status 13	Unsigned-8		21	Device-Specific Status 13	Unsigned-8	
				22	Device-Specific Status 14	Unsigned-8		22	Device-Specific Status 14	Unsigned-8	
				23	Device-Specific Status 15	Unsigned-8		23	Device-Specific Status 15	Unsigned-8	
				24	Device-Specific Status 16	Unsigned-8		24	Device-Specific Status 16	Unsigned-8	
49	Write PV Transducer Serial Number	W	3	0-2	PV Transducer Serial Number	Unsigned-24	3	0-2	PV Transducer Serial Number	Unsigned-24	0,1,5,7,32
50	Read Dynamic Variable Assignments	R	-				4	0	Device Variable Assigned to the PV	Unsigned-8	0
								1	Device Variable Assigned to the SV	Unsigned-8	
								2	Device Variable Assigned to the TV	Unsigned-8	
								3	Device Variable Assigned to the QV	Unsigned-8	

Command			Request Data				Response Data				Response Code
No.	Description	Type	Size	Byte	Name	Format	Size	Byte	Name	Format	
51	Write Dynamic Variable Assignments	W	4	0	Device Variable Assigned to the PV	Unsigned-8	4	0	Device Variable Assigned to the PV	Unsigned-8	0,2,5,1,7,32
				1	Device Variable Assigned to the SV	Unsigned-8		1	Device Variable Assigned to the SV	Unsigned-8	
				2	Device Variable Assigned to the TV	Unsigned-8		2	Device Variable Assigned to the TV	Unsigned-8	
				3	Device Variable Assigned to the QV	Unsigned-8		3	Device Variable Assigned to the QV	Unsigned-8	
53	Write Device Variable Units	W	2	0	Device Variable Code	Unsigned-8	2	0	Device Variable Code	Unsigned-8	0,11,12,1,5,7,32
				1	Device Variable Units Code	Unsigned-8		1	Device Variable Units Code	Unsigned-8	
54	Read Device Variable Information	R	1	0	Device Variable Code	Unsigned-8	21	0	Device Variable Code	Unsigned-8	0,2,1,5
				1-3	Device Variable Transducer Serial Number	Unsigned-8		1-3	Device Variable Transducer Serial Number	Unsigned-8	
				4	Device Variable Units Code	Unsigned-8		4	Device Variable Units Code	Unsigned-8	
				5-8	Device Variable Upper Transducer Limit	Float		5-8	Device Variable Upper Transducer Limit	Float	
				9-12	Device Variable Upper Transducer Limit	Float		9-12	Device Variable Upper Transducer Limit	Float	
				13-16	Device Variable Damping Value	Float		13-16	Device Variable Damping Value	Float	
55	Write Device Variable Damping Value	W	5	0	Device Variable Code	Unsigned-8	5	0	Device Variable Code	Unsigned-8	0,2,3,4,5,1,7,32
				1-4	Device Variable Damping Value	Float		1-4	Device Variable Damping Value	Float	
59	Write Number of Response Preambles	W	1	0	Number of Preambles Slave to Master	Unsigned-8	1	0	Number of Preambles Slave to Master	Unsigned-8	0,3,4,1,5,7,32
60	Read Analog Channel and Percent Of Range	R	1	0	Analog Channel Number Code	Unsigned-8	10	0	Analog Channel Number Code	Unsigned-8	0,2,1,5
				1	Analog Channel Units Code	Unsigned-8		1	Analog Channel Units Code	Unsigned-8	
				2-5	Analog Channel Level	Float		2-5	Analog Channel Level	Float	
				6-9	Analog Channel Percent Of Range	Float		6-9	Analog Channel Percent Of Range	Float	
63	Read Analog Channel Information	R	1	0	Analog Channel Number Code	Unsigned-8	17	0	Analog Channel Number Code	Unsigned-8	0,2,1,5
				1	Analog Channel Alarm Selection Code	Unsigned-8		1	Analog Channel Alarm Selection Code	Unsigned-8	
				2	Analog Channel Transfer Function Code	Unsigned-8		2	Analog Channel Transfer Function Code	Unsigned-8	
				3	Analog Channel Upper, Lower Range Values Units Code	Unsigned-8		3	Analog Channel Upper, Lower Range Values Units Code	Unsigned-8	
				4-7	Analog Channel Upper Range Value	Float		4-7	Analog Channel Upper Range Value	Float	
				8-11	Analog Channel Lower Range Value	Float		8-11	Analog Channel Lower Range Value	Float	
				12-15	Analog Channel Damping Value	Float		12-15	Analog Channel Damping Value	Float	
				16	Analog Channel Flags	Unsigned-8		16	Analog Channel Flags	Unsigned-8	
64	Write Analog Channel Additional Damping Value	W	5	0	Analog Channel Number Code	Unsigned-8	5	0	Analog Channel Number Code	Unsigned-8	0,2,3,4,1,5,7,32
				1-4	Analog Channel Additional Damping Value	Float		1-4	Analog Channel Additional Damping Value	Float	
65	Write Analog Channel Range Values	W	10	0	Analog Channel Number Code	Unsigned-8	10	0	Analog Channel Number Code	Unsigned-8	0,5,6,7,8,9,10,11,12,13,14,15,16,28,29
				1	Analog Channel Upper, Lower Range Values Units Codes	Unsigned-8		1	Analog Channel Upper, Lower Range Values Units Codes	Unsigned-8	
				2-5	Analog Channel Upper Range Value	Float		2-5	Analog Channel Upper Range Value	Float	
				6-9	Analog Channel Lower Range Value	Float		6-9	Analog Channel Lower Range Value	Float	
66	Enter/Exit Fixed Analog Channel Mode	C	6	0	Analog Channel Number Code	Unsigned-8	6	0	Analog Channel Number Code	Unsigned-8	0,3,4,11,12,15,16,1,5,32
				1	Analog Channel Units Code	Unsigned-8		1	Analog Channel Units Code	Unsigned-8	
				2-5	Fixed Analog Channel Level	Float		2-5	Fixed Analog Channel Level	Float	

Command			Request Data				Response Data				Response Code
No.	Description	Type	Size	Byte	Name	Format	Size	Byte	Name	Format	
67	Trim Analog Channel Zero	C	6	0	Analog Channel Number Code	Unsigned-8	6	0	Analog Channel Number Code	Unsigned-8	0,3,4,9,11,1,5,7,32
				1	Analog Channel Units Code	Unsigned-8		1	Analog Channel Units Code	Unsigned-8	
				2-5	Externally Measured Analog Channel Level	Float		2-5	Actual Analog Channel Level	Float	
68	Trim Analog Channel Gain	C	6	0	Analog Channel Number Code	Unsigned-8	6	0	Analog Channel Number Code	Unsigned-8	0,3,4,9,11,15,1,5,7,32
				1	Analog Channel Units Code	Unsigned-8		1	Analog Channel Units Code	Unsigned-8	
				2-5	Externally Measured Analog Channel Level	Float		2-5	Actual Analog Channel Level	Float	
70	Read Analog Channel Endpoint Values	R	1	0	Analog Channel Number Code	Unsigned-8	10	0	Analog Channel Number Code	Unsigned-8	0,2,5,32
								1	Analog Channel Upper and Lower Endpoint Value Units Code	Unsigned-8	
								2-5	Analog Channel Upper Endpoint Value	Float	
								6-9	Analog Channel Lower Endpoint Value	Float	
122	Write Device ID Number	W	3	0-2	Device ID Number	Unsigned-24	3	0-2	Device ID Number	Unsigned-24	0,1,5,7,32
126	Write Hardware Revision	W	4	0-2	Device ID Number	Unsigned-24	1	0	Hardware Revision	Unsigned-8	0,5,7,16,32
				3	Hardware Revision	Unsigned-8					
128	Read Static Data - Material and Sensor	R	-				12	0	Flange Type	Unsigned-8	0
								1-4	-	-	
								5-10	Sensor Model	Packed ASCII	
								11	Sensor Material	Unsigned-8	
129	Write Static Data - Material and Sensor	W	12	0	Flange Type	Unsigned-8	12	0	Flange Type	Unsigned-8	0,1,5,7,32
								1-4	-	-	
								5-10	Sensor Model	Packed ASCII	
								11	Sensor Material	Unsigned-8	
130	Read Device Variables (Transmitter Specific Version)	R	4	0	Slot 0: Device Variable Code	Unsigned-8	24	0	Slot 0: Device Variable Code	Unsigned-8	0,2,5
				1	Slot 1: Device Variable Code	Unsigned-8		1	Slot 0: Units Code	Unsigned-8	
				2	Slot 2: Device Variable Code	Unsigned-8		2-5	Slot 0: Device Variable Value	Float	
				3	Slot 3: Device Variable Code	Unsigned-8		6	Slot 1: Device Variable Code	Unsigned-8	
								7	Slot 1: Units Code	Unsigned-8	
								8-11	Slot 1: Device Variable Value	Float	
								12	Slot 2: Device Variable Code	Unsigned-8	
								13	Slot 2: Units Code	Unsigned-8	
								14-17	Slot 2: Device Variable Value	Float	
								18	Slot 3: Device Variable Code	Unsigned-8	
								19	Slot 3: Units Code	Unsigned-8	
								20-23	Slot 3: Device Variable Value	Float	
131	Read Static Data - Setup Parameters	R	-				14	0	Direction Configuration Code	Unsigned-8	0
								1-4	Density High Limit (Slug Flow)	Float	
								5-8	Density Low Limit (Slug Flow)	Float	
								9	Low Mass Flow Cutoff Units Code	Unsigned-8	
								10-13	Low Mass Flow Cutoff	Float	

Command			Request Data				Response Data				Response Code
No.	Description	Type	Size	Byte	Name	Format	Size	Byte	Name	Format	
132	Read Sensor Flow Calibration Factor	R	-				20	0-3	SK20	Float	0
								4-7	SKt	Float	
								8-11	Calibration Temperature (Inner)	Float	
								12-15	Calibration Temperature (Outer)	Float	
								16-19	Calibration Frequency	Float	
134	Write Direction Configuration	W	1	0	Direction Configuration Code	Unsigned-8	1	0	Direction Configuration Code	Unsigned-8	0,2,1,5,7,32
135	Write Frequency Output #1 Factor	W	17	0-7	Pulse1 Frequency Factor	Double	17	0-7	Pulse1 Frequency Factor	Double	0,9,10,1,5,7,32
				8	Pulse1 Flow Rate Factor Units Code	Unsigned-8		8	Pulse1 Flow Rate Factor Units Code	Unsigned-8	
				9-16	Pulse1 Flow Rate Factor	Double		9-16	Pulse1 Flow Rate Factor	Double	
136	Write Frequency Output #2 Factor	W	17	0-7	Pulse2 Frequency Factor	Double	17	0-7	Pulse2 Frequency Factor	Double	0,9,10,1,5,7,32
				8	Pulse2 Flow Rate Factor Units Code	Unsigned-8		8	Pulse2 Flow Rate Factor Units Code	Unsigned-8	
				9-16	Pulse2 Flow Rate Factor	Double		9-16	Pulse2 Flow Rate Factor	Double	
137	Write Measurement Low Mass Flow Cutoff	W	5	0	Low Mass Flow Cutoff Units Code	Unsigned-8	5	0	Low Mass Flow Cutoff Units Code	Unsigned-8	0,3,4,1,5,7,32
				1-4	Low Mass Flow Cutoff	Float		1-4	Low Mass Flow Cutoff	Float	
138	Write Sensor Limit	W	9	0	Device Variable Code	Unsigned-8	9	0	Device Variable Code	Unsigned-8	0,2,1,5,7,32
				1-4	Upper Transducer Limit	Float		1-4	Upper Transducer Limit	Float	
				5-8	Lower Transducer Limit	Float		5-8	Lower Transducer Limit	Float	
139	Read Frequency Output #1 Factor	R	-				17	0-7	Pulse1 Frequency Factor	Double	0
								8	Pulse1 Flow Rate Factor Units Code	Unsigned-8	
								9-16	Pulse1 Flow Rate Factor	Double	
140	Read Volumetric Flow Parameter	R	-				18	0-13	Dummy	Unsigned-8	0
								14-17	Volumetric Flow Coefficient	Float	
141	Write Volumetric Flow Parameter	W	18	0-13	Dummy	Unsigned-8	18	0-13	Dummy	Unsigned-8	0,3,4,1,5,7,32
				14-17	Volumetric Flow Coefficient	Float		14-17	Volumetric Flow Coefficient	Float	
142	Read Frequency Output #2 Factor	R	-				17	0-7	Pulse2 Frequency Factor	Double	0
								8	Pulse2 Flow Rate Factor Units Code	Unsigned-8	
								9-16	Pulse2 Flow Rate Factor	Double	
143	Set PV Zero & Measure	C	-				-				0,1,7,32
144	Perform Self Diagnosis	C	1	0	Self-Diagnosis Mode	Unsigned-8	1	0	Self-Diagnosis Mode	Unsigned-8	0,2,1,5,32
145	Enter/Exit Fixed Frequency #1 Mode	C	8	0-3	Frequency Output #1 Level	Float	8	0-3	Frequency Output #1 Level	Float	0,3,4,1,5,32
				4-7	Number of Times Frequency Output #1	Float		4-7	Number of Times Frequency Output #1	Float	
146	Totalizer #1 Control	C	1	0	Totalizer #1 Control Code	Unsigned-8	1	0	Totalizer #1 Control Code	Unsigned-8	0,2,1,5,32
147	Enter/Exit Fixed Status Output Mode	C	1	0	Status Output Level Code	Unsigned-8	1	0	Status Output Level Code	Unsigned-8	0,2,1,5,7,32
148	Read Status I/O Level	R	-				2	0	Status Input Level Code	Unsigned-8	0
								1	Status Output Level Code	Unsigned-8	

Command			Request Data				Response Data				Response Code
No.	Description	Type	Size	Byte	Name	Format	Size	Byte	Name	Format	
149	Write Dynamic Variable Assignments (Transmitter Specific Version)	W	4	0	Device Variable assigned to the PV	Unsigned-8	4	0	Device Variable assigned to the PV	Unsigned-8	0,2,5,1,7,32
				1	Device Variable assigned to the SV	Unsigned-8		1	Device Variable assigned to the SV	Unsigned-8	
				2	Device Variable assigned to the TV	Unsigned-8		2	Device Variable assigned to the TV	Unsigned-8	
				3	Device Variable assigned to the QV	Unsigned-8		3	Device Variable assigned to the QV	Unsigned-8	
150	Read Sensor Type	R	-				6	0	Sensor Type	Unsigned-8	0
								1	Nominal Size (unit)	Unsigned-8	
								2-5	Nominal Size (value)	Float	
151	Enter/Exit Fixed Frequency #2 Mode	C	8	0-3	Fixed Frequency #2 Output Level	Float	8	0-3	Fixed Frequency #2 Output Level	Float	0,3,4,5,32
				4-7	Number of Times Frequency #2 Output	Float		4-7	Number of Times Frequency #2 Output	Float	
152	Totalizer #2 Control	C	1	0	Totalizer #2 Control Code	Unsigned-8	1	0	Totalizer #2 Control Code	Unsigned-8	0,2,1,5,32
153	Read Measurement Mode	R	1	0	Measurement Mode	Unsigned-8	1	0	Measurement Mode	Unsigned-8	0
154	Write Measurement Mode	W	1	0	Measurement Mode	Unsigned-8	1	0	Measurement Mode	Unsigned-8	0,2,1,5,7,32
155	Write Sensor Flow Calibration Factor	W	20	0-3	SK20	Float	20	0-3	SK20	Float	0,9,10,11,12,13,15,1,5,7,32
				4-7	SKt	Float		4-7	SKt	Float	
				8-11	Calibration Temperature (Inner)	Float		8-11	Calibration Temperature (Inner)	Float	
				12-15	Calibration Temperature (Outer)	Float		12-15	Calibration Temperature (Outer)	Float	
				16-19	Calibration Frequency	Float		16-19	Calibration Frequency	Float	
156	Write Sensor Type	W	6	0	Sensor Type	Unsigned-8	6	0	Sensor Type	Unsigned-8	0,2,1,5,7,32
				1	Nominal Size (unit)	Unsigned-8		1	Nominal Size (unit)	Unsigned-8	
				2-5	Nominal Size (value)	Float		2-5	Nominal Size (value)	Float	
157	Write Density Limits	W	8	0-3	Density High Limit (Slug Flow)	Float	8	0-3	Density High Limit (Slug Flow)	Float	0,9,10,11,12,1,5,7,32
				4-7	Density Low Limit (Slug Flow)	Float		4-7	Density Low Limit (Slug Flow)	Float	
158	Read Flow Parameters 1	R	-				20	0-3	SK20	Float	0
								4-7	SKt	Float	
								8-11	Calibration Temperature (Inner)	Float	
								12-15	Calibration Temperature (Outer)	Float	
								16-19	Calibration Frequency	Float	
159	Write Flow Parameters 1	W	20	0-3	SK20	Float	20	0-3	SK20	Float	0,9,10,11,12,13,1,5,7,32
				4-7	SKt	Float		4-7	SKt	Float	
				8-11	Calibration Temperature (Inner)	Float		8-11	Calibration Temperature (Inner)	Float	
				12-15	Calibration Temperature (Outer)	Float		12-15	Calibration Temperature (Outer)	Float	
				16-19	Calibration Frequency	Float		16-19	Calibration Frequency	Float	

Command			Request Data				Response Data				Response Code
No.	Description	Type	Size	Byte	Name	Format	Size	Byte	Name	Format	
160	Read Device Variables (Maintenance Version)	R	4	0	Slot 0: Device Variable Code	Unsigned-8	24	0	Slot 0: Device Variable Code	Unsigned-8	0,2,5
				1	Slot 1: Device Variable Code	Unsigned-8		1	Slot 0: Units Code	Unsigned-8	
				2	Slot 2: Device Variable Code	Unsigned-8		2-5	Slot 0: Device Variable Value	Float	
				3	Slot 3: Device Variable Code	Unsigned-8		6	Slot 1: Device Variable Code	Unsigned-8	
								7	Slot 1: Units Code	Unsigned-8	
								8-11	Slot 1: Device Variable Value	Float	
								12	Slot 2: Device Variable Code	Unsigned-8	
								13	Slot 2: Units Code	Unsigned-8	
								14-17	Slot 2: Device Variable Value	Float	
								18	Slot 3: Device Variable Code	Unsigned-8	
								19	Slot 3: Units Code	Unsigned-8	
								20-23	Slot 3: Device Variable Value	Float	
				161	Read Alarm Output Selection	R		-			
			1				Sensor Failure Code		Unsigned-8		
			2				Transmitter Failure Code		Unsigned-8		
			3				Parameter Alarm Code		Unsigned-8		
			4				Calibration Failure Code		Unsigned-8		
			5				Slug Flow Code		Unsigned-8		
			6				Transmitter Alarm Code		Unsigned-8		
			7				Fixed Output Code		Unsigned-8		
			8				Calibration in Progress Code		Unsigned-8		
			9				Concentration Alarm Code		Unsigned-8		
			10				Error Output Analog		Unsigned-8		
			11				Error Output Pulse		Unsigned-8		
162	Write Alarm Output Selection	W	12	0	Saturated Alarm Code	Unsigned-8	12	0	Saturated Alarm Code	Unsigned-8	0,2,1,5,7,32
				1	Sensor Failure Code	Unsigned-8		1	Sensor Failure Code	Unsigned-8	
				2	Transmitter Failure Code	Unsigned-8		2	Transmitter Failure Code	Unsigned-8	
				3	Parameter Alarm Code	Unsigned-8		3	Parameter Alarm Code	Unsigned-8	
				4	Calibration Failure Code	Unsigned-8		4	Calibration Failure Code	Unsigned-8	
				5	Slug Flow Code	Unsigned-8		5	Slug Flow Code	Unsigned-8	
				6	Transmitter Alarm Code	Unsigned-8		6	Transmitter Alarm Code	Unsigned-8	
				7	Fixed Output Code	Unsigned-8		7	Fixed Output Code	Unsigned-8	
				8	Calibration in Progress Code	Unsigned-8		8	Calibration in Progress Code	Unsigned-8	
				9	Concentration Alarm Code	Unsigned-8		9	Concentration Alarm Code	Unsigned-8	
				10	Error Output Analog	Unsigned-8		10	Error Output Analog	Unsigned-8	
				11	Error Output Pulse	Unsigned-8		11	Error Output Pulse	Unsigned-8	
165	Read H/L Alarm Parameters	R	-				22	0	H/L Alarm Type Code	Unsigned-8	0
								1	H/L Alarm Unit Code	Unsigned-8	
								2-9	High Alarm Point	Double	
								10-17	Low Alarm Point	Double	
								18-21	H/L Alarm Hysteresis	Float	

Command			Request Data				Response Data				Response Code
No.	Description	Type	Size	Byte	Name	Format	Size	Byte	Name	Format	
166	Write H/L Alarm Parameters	W	22	0	H/L Alarm Type Code	Unsigned-8	22	0	H/L Alarm Type Code	Unsigned-8	0,2,9,10,11,13,15,7,32
				1	H/L Alarm Units Code	Unsigned-8		1	H/L Alarm Units Code	Unsigned-8	
				2-9	High Alarm Point	Double		2-9	High Alarm Point	Double	
				10-17	Low Alarm Point	Double		10-17	Low Alarm Point	Double	
				18-21	H/L Alarm Hysteresis	Float		18-21	H/L Alarm Hysteresis	Float	
169	Read Concentration Parameters	R	1	0	Parameter Number Code (*Set only 0)	Unsigned-8	25	0	Parameter Number Code	Unsigned-8	0,2,5
								1-4	Parameter 0 (Concentration Adjust Gain)	Float	
								5-8	Parameter 1 (Concentration Adjust Offset)	Float	
								9-12	Reserved	Float	
								13-16	Reserved	Float	
								17-20	Reserved	Float	
								21-24	Reserved	Float	
170	Write Concentration Parameters	R	25	0	Parameter Number Code (*Set only 0)	Unsigned-8	25	0	Parameter Number Code	Unsigned-8	0,2,5,9,10
				1-4	Parameter 0 (Concentration Adjust Gain)	Float		1-4	Parameter 0 (Concentration Adjust Gain)	Float	
				5-8	Parameter 1 (Concentration Adjust Offset)	Float		5-8	Parameter 1 (Concentration Adjust Offset)	Float	
				9-12	Parameter 2 (Undefined (*Set only 0))	Float		9-12	Parameter 2 (Undefined (*Set only 0))	Float	
				13-16	Parameter 3 (Undefined (*Set only 0))	Float		13-16	Parameter 3 (Undefined (*Set only 0))	Float	
				17-20	Parameter 4 (Undefined (*Set only 0))	Float		17-20	Parameter 4 (Undefined (*Set only 0))	Float	
				21-24	Parameter 5 (Undefined (*Set only 0))	Float		21-24	Parameter 5 (Undefined (*Set only 0))	Float	
171	Write Status I/O Mode	W	2	0	Status Input Mode	Unsigned-8	2	0	Status Input Mode	Unsigned-8	0,9,10,15,7,32
				1	Status Output Mode	Unsigned-8		1	Status Output Mode	Unsigned-8	
172	Write Status I/O Function	W	3	0	Status Input Function	Unsigned-8	3	0	Status Input Function	Unsigned-8	0,5,7,9,10,32
				1	Status Output Function	Unsigned-8		1	Status Output Function	Unsigned-8	
				2	H/L Alarm Assign	Unsigned-8		2	H/L Alarm Assign	Unsigned-8	
173	Read Status I/O Function	R	-				3	0	Status Input Function	Unsigned-8	0,5,7,9,10,11,32
								1	Status Output Function	Unsigned-8	
								2	H/L Alarm Assign	Unsigned-8	
174	Read Status I/O Mode	R	-				2	0	Status Input Mode	Unsigned-8	0
								1	Status Output Mode	Unsigned-8	
175	Read Sensor Temperature Calibration Factor	R	-				24	0-3	Low Temp Adjust Value (Inner)	Float	0
								4-7	Low Temp Adjust Value (Outer)	Float	
								8-11	Adjust Low Temp	Float	
								12-15	High Temp Adjust Value (Inner)	Float	
								16-19	High Temp Adjust Value (Outer)	Float	
								20-23	Adjust High Temp	Float	
177	Read Analog Output Adjustment Value	R	-				16	0-3	Analog1 4mA Adjust Value	Float	0
								4-7	Analog1 20mA Adjust Value	Float	
								8-11	Analog2 4mA Adjust Value	Float	
								12-15	Analog2 20mA Adjust Value	Float	
180	Write Fault Duration	W	4	0-3	Fault Duration	Float	4	0-3	Fault Duration	Float	0,3,4,15,7,32

Command			Request Data				Response Data				Response Code
No.	Description	Type	Size	Byte	Name	Format	Size	Byte	Name	Format	
181	Read Fault Duration	R	-				4	0-3	Fault Duration	Float	0
182	Read Settled Density	R	-				5	0	Settled Density	Unsigned-8	0
								1-4	Settled Density Value	Float	
183	Write Settled Density	W	5	0	Settled Density	Unsigned-8	5	0	Settled Density	Unsigned-8	0,2,3,4,1,5,7,32
				1-4	Settled Density Value	Float		1-4	Settled Density Value	Float	
184	Read Slave Address for Modbus	R	-				1	0	Slave Address for Modbus	Unsigned-8	0
185	Write Slave Address for Modbus	W	1	0	Slave Address for Modbus	Unsigned-8	1	0	Slave Address for Modbus	Unsigned-8	0,3,4,1,5,7,32
187	Read Flow Parameters 2	R					4	0-3	SKM	Float	0
188	Write Flow Parameters 2	W	4	0-3	SKM	Float	4	0-3	SKM	Float	0,3,4,1,5,7,32
189	Read Auto Zero Parameters	R	-				6	0	Sensor Zero Units Code	Unsigned-8	0
								1-4	Sensor Zero Value	Float	
								5	Auto Zero Code*	Unsigned-8	
190	Write Auto Zero Parameters	W	6	0	Sensor Zero Units Code	Unsigned-8	6	0	Sensor Zero Units Code	Unsigned-8	0,9,1,5,7,32
				1-4	Sensor Zero Value	Float		1-4	Sensor Zero Value	Float	
				5	Auto Zero Code*	Unsigned-8		5	Auto Zero Code*	Unsigned-8	
191	Read Dummy input 1	R	-				17	0	Dummy input 1	Unsigned-8	0
								1-4	Dummy Phase Difference Value	Float	
								5-8	Dummy Drive Frequency Value	Float	
								9-12	Dummy Temperature Inner Value	Float	
								13-16	Dummy Temperature Outer Value	Float	
192	Write Dummy input 1	W	17	0	Dummy input 1	Unsigned-8	17	0	Dummy input 1	Unsigned-8	0,9,10,11,12,13,1,5,7,32
				1-4	Dummy Phase Difference Value	Float		1-4	Dummy Phase Difference Value	Float	
				5-8	Dummy Drive Frequency Value	Float		5-8	Dummy Drive Frequency Value	Float	
				9-12	Dummy Temperature Inner Value	Float		9-12	Dummy Temperature Inner Value	Float	
				13-16	Dummy Temperature Outer Value	Float		13-16	Dummy Temperature Outer Value	Float	
193	Read Dummy input 2	R	-				23	0	Dummy input 1	Unsigned-8	0
								1	Dummy Mass Flow Units Code	Unsigned-8	
								2-5	Dummy Mass Flow Value	Float	
								6-9	Dummy Density Value	Float	
								10-13	Dummy Temperature Inner Value	Float	
								14-17	Dummy Temperature Outer Value	Float	
								18	Dummy Volume Flow Units Code	Unsigned-8	
19-22	Dummy Volume Flow Value	Float									

Command			Request Data				Response Data				Response Code
No.	Description	Type	Size	Byte	Name	Format	Size	Byte	Name	Format	
194	Write Dummy input 2	W	23	0	Simulation input 1	Unsigned-8	23	0	Dummy input 1	Unsigned-8	0,9,10,11,15,29,1,5,7,32
				1	Dummy Mass Flow Units Code	Unsigned-8		1	Dummy Mass Flow Units Code	Unsigned-8	
				2-5	Dummy Mass Flow Value	Float		2-5	Dummy Mass Flow Value	Float	
				6-9	Dummy Density Value	Float		6-9	Dummy Density Value	Float	
				10-13	Dummy Temperature Inner Value	Float		10-13	Dummy Temperature Inner Value	Float	
				14-17	Dummy Temperature Outer Value	Float		14-17	Dummy Temperature Outer Value	Float	
				18	Dummy Volume Flow Units Code	Unsigned-8		18	Dummy Volume Flow Units Code	Unsigned-8	
				19-22	Dummy Volume Flow Value	Float		19-22	Dummy Volume Flow Value	Float	
195	Read Specified Low Flow Cutoff	R	1	0	Cutoff Type Code	Unsigned-8	6	0	Cutoff Type Code	Unsigned-8	0,2
								1	Low Flow Cutoff Units Code	Unsigned-8	
								2-5	Low Flow Cutoff	Float	
196	Write Specified Low Flow Cutoff	W	6	0	Cutoff Type Code	Unsigned-8	6	0	Cutoff Type Code	Unsigned-8	0,3,4,13,1,5,7,32
				1	Low Flow Cutoff Units Code	Unsigned-8		1	Low Flow Cutoff Units Code	Unsigned-8	
				2-5	Low Flow Cutoff	Float		2-5	Low Flow Cutoff	Float	
197	Read Present Output Frequency	R					4	0-3	Present Output Frequency	Float	0
198	Read Drive Out Threshold	R					4	0-3	Drive Out Threshold	Float	0
199	Write Drive Out Threshold	W	4	0-3	Drive Out Threshold	Float	4	0-3	Drive Out Threshold	Float	0,3,4,1,5,7,32
200	Read Forward Total	R	-				16	0-7	Forward Total #1 Count	Double	0
								8-15	Forward Total #2 Count	Double	
201	Read Density Compensation	R	-				10	0	Density Compensation Code	Unsigned-8	0
								1	Standard Temperature Units Code	Unsigned-8	
								2-5	Standard Temperature	Float	
								6-9	Expansion Coefficient	Float	
202	Write Density Compensation	W	10	0	Density Compensation Code	Unsigned-8	10	0	Density Compensation Code	Unsigned-8	0,9,10,11,1,5,7,32
				1	Standard Temperature Units Code	Unsigned-8		1	Standard Temperature Units Code	Unsigned-8	
				2-5	Standard Temperature	Float		2-5	Standard Temperature	Float	
				6-9	Expansion Coefficient	Float		6-9	Expansion Coefficient	Float	
203	Read Reverse Total	R	-				16	0-7	Reverse Total #1 Count	Double	0
								8-15	Reverse Total #2 Count	Double	
204	Read Difference Total	R	-				16	0-7	Difference Total #1 Count	Double	0
								8-15	Difference Total #2 Count	Double	
205	Read Total Flow	R	-				18	0	Total #1 Flow Units Code	Unsigned-8	0
								1-8	Total #1 Flow	Double	
								9	Total #2 Flow Units Code	Unsigned-8	
								10-17	Total #2 Flow	Double	
206	Read Analog/Pulse Assign Mode	R	-				4	0	Analog 1 Mode	Unsigned-8	0
								1	Analog 2 Mode	Unsigned-8	
								2	Pulse 1 Mode	Unsigned-8	
								3	Pulse 2 Mode	Unsigned-8	

Command			Request Data				Response Data				Response Code
No.	Description	Type	Size	Byte	Name	Format	Size	Byte	Name	Format	
207	Perform LCD Test	C	1	0	LCD Test Mode	Unsigned-8	1	0	LCD Test Mode	Unsigned-8	0,2,1,5,32
208	Read Pulse Weight	R	-				18	0	Pulse #1 Weight Units Code	Unsigned-8	0
								1-8	Pulse #1 Weight	Double	
								9	Pulse #2 Weight Units Code	Unsigned-8	
								10-17	Pulse #2 Weight	Double	
209	Perform Master Reset	C	1	0	dummy	Unsigned-8	1	0	dummy	Unsigned-8	0,1,5
210	Perform 1-Point Density Calibration	C	4	0-3	Calibration Density	Float	4	0-3	Calibration Density	Float	0,3,4,1,5,7,32
211	Read Sensor Density Calibration Factor	R	-				8	0-3	Calibration Density	Float	0
								4-7	fw20	Float	
212	Write Sensor Density Calibration Factor	W	8	0-3	Calibration Density	Float	8	0-3	Calibration Density	Float	0,1,5,7,9,32
				4-7	fw20	Float		4-7	fw20	Float	
213	Read Density Parameters 1	R	-				12	0-3	Density Calibration Temperature (Inner)	Float	0
								4-7	Density Calibration Temperature (Outer)	Float	
								8-11	Density Calibration Frequency	Float	
214	Write Density Parameters 1	W	12	0-3	Density Calibration Temperature (Inner)	Float	12	0-3	Density Calibration Temperature (Inner)	Float	0,9,10,11,1,5,7,32
				4-7	Density Calibration Temperature (Outer)	Float		4-7	Density Calibration Temperature (Outer)	Float	
				8-11	Density Calibration Frequency	Float		8-11	Density Calibration Frequency	Float	
215	Read Density Slope Parameters 1	R	-				16	0-3	A	Float	0
								4-7	B	Float	
								8-11	C	Float	
								12-15	K	Float	
216	Write Density Slope Parameters 1	W	16	0-3	A	Float	16	0-3	A	Float	0,9,10,11,12,1,5,7,32
				4-7	B	Float		4-7	B	Float	
				8-11	C	Float		8-11	C	Float	
				12-15	K	Float		12-15	K	Float	
217	Read Density Slope Parameters 2	R	-				8	0-3	fw20kd	Float	0
								4-7	fa20kd	Float	
218	Write Density Slope Parameters 2	W	8	0-3	fw20kd	Float	8	0-3	fw20kd	Float	0,9,10,1,5,7,32
				4-7	fa20kd	Float		4-7	fa20kd	Float	
219	Read Density Parameters 2	R	-				4	0-3	Frequency Coefficient Beta	Float	0
220	Write Density Parameters 2	W	4	0-3	Frequency Coefficient Beta	Float	4	0-3	Frequency Coefficient Beta	Float	0,9,1,5,7,32
221	Read DSP Other Parameters 1	R	-				24	0-3	SKg3	Float	0
								4-7	SKg4	Float	
								8-11	Resistivity Revise	Float	
								12-15	Adjust Frequency	Float	
								16-19	SKd1	Float	
								20-23	SKd2	Float	

Command			Request Data				Response Data				Response Code
No.	Description	Type	Size	Byte	Name	Format	Size	Byte	Name	Format	
222	Write DSP Other Parameters 1	W	24	0-3	SKg3	Float	24	0-3	SKg3	Float	0,3,4,1,5,7,32
				4-7	SKg4	Float		4-7	SKg4	Float	
				8-11	Resistivity Revise	Float		8-11	Resistivity Revise	Float	
				12-15	Adjust Frequency	Float		12-15	Adjust Frequency	Float	
				16-19	SKd1	Float		16-19	SKd1	Float	
				20-23	SKd2	Float		20-23	SKd2	Float	
223	Read DSP Other Parameters 2	R	-				24	0-3	Calibration Temperature 0 Low	Float	0
								4-7	Calibration Temperature 0 High	Float	
								8-11	Calibration Temperature 1 Low	Float	
								12-15	Calibration Temperature 1 High	Float	
								16-19	Calibration Temperature 2 Low	Float	
								20-23	Calibration Temperature 2 High	Float	
224	Write DSP Other Parameters 2	W	24	0-3	Calibration Temperature 0 Low	Float	24	0-3	Calibration Temperature 0 Low	Float	0,3,4,1,5,7,32
				4-7	Calibration Temperature 0 High	Float		4-7	Calibration Temperature 0 High	Float	
				8-11	Calibration Temperature 1 Low	Float		8-11	Calibration Temperature 1 Low	Float	
				12-15	Calibration Temperature 1 High	Float		12-15	Calibration Temperature 1 High	Float	
				16-19	Calibration Temperature 2 Low	Float		16-19	Calibration Temperature 2 Low	Float	
				20-23	Calibration Temperature 2 High	Float		20-23	Calibration Temperature 2 High	Float	
225	Read DSP Other Parameters 3	R	-				24	0-3	ADC Interface Index	Float	0
								4-7	Phase Difference Shift Number	Float	
								8-11	Bandpass Filter	Float	
								12-15	SKg1	Float	
								16-19	SKg2	Float	
								20-23	Allowed Drive Resistance	Float	
226	Write DSP Other Parameters 1	W	24	0-3	ADC Interface Index	Float	24	0-3	ADC Interface Index	Float	0,3,4,1,5,7,32
				4-7	Phase Difference Shift Number	Float		4-7	Phase Difference Shift Number	Float	
				8-11	Bandpass Filter	Float		8-11	Bandpass Filter	Float	
				12-15	SKg1	Float		12-15	SKg1	Float	
				16-19	SKg2	Float		16-19	SKg2	Float	
				20-23	Allowed Drive Resistance	Float		20-23	Allowed Drive Resistance	Float	
227	Read DSP Version	R	-				8	0-3	DSP Version	Unsigned-32	0
								4-7	Flow CPU Version	Unsigned-32	
228	Factory Settings Operation	C	1	0	Factory Settings Operation Mode	Unsigned-8	1	0	Factory Settings Operation Mode	Unsigned-8	0,2,1,5,7,32
229	Load/Store Factory Settings	C	1	0	Factory Settings Load/Store Mode	Unsigned-8	1	0	Factory Settings Load/Store Mode	Unsigned-8	0,2,1,5,7,32
230	Read Key Protect	R	-				1	0	Key Protect	Unsigned-8	0
231	Write Key Protect	W	1	0	Key Protect	Unsigned-8	1	0	Key Protect	Unsigned-8	0,2,1,5,7,32

Command			Request Data				Response Data				Response Code
No.	Description	Type	Size	Byte	Name	Format	Size	Byte	Name	Format	
232	Read Error Log	R	4	0-3	Error Log Address	Unsigned-32	24	0-3	Error Log Address	Unsigned-32	0,10,1,5,7,32
								4	Error Log 1 Date Year 1	Unsigned-8	
								5	Error Log 1 Date Month 1	Unsigned-8	
								6	Error Log 1 Date Day 1	Unsigned-8	
								7	Error Log 1 Date Hour 1	Unsigned-8	
								8	Error Log 1 Date Min 1	Unsigned-8	
								9	Error Log 1 Date Sec 1	Unsigned-8	
								10	Error Log 1 Date Number 1	Unsigned-8	
								11	Error Log 1 Date Occurrence 1	Unsigned-8	
								12	Error Log 1 Date Year 2	Unsigned-8	
								13	Error Log 1 Date Month 2	Unsigned-8	
								14	Error Log 1 Date Day 2	Unsigned-8	
								15	Error Log 1 Date Hour 2	Unsigned-8	
								16	Error Log 1 Date Min 2	Unsigned-8	
								17	Error Log 1 Date Sec 2	Unsigned-8	
								18	Error Log 1 Date Number 2	Unsigned-8	
								19	Error Log 1 Date Occurrence 2	Unsigned-8	
								20-23	Error Log Current Address	Unsigned-32	
233	Factory Reset	C	1	1	dummy	Unsigned-8	1	1	dummy	Unsigned-8	0,1,5
234	Read Xmtr Temperature	W	-				4	0-3	Xmtr Temperature	Float	0
235	Write Analog/Pulse Assign Mode	W	4	0	Analog 1 Mode	Unsigned-8	4	0	Analog 1 Mode	Unsigned-8	0,2,1,5,7,32
				1	Analog 2 Mode	Unsigned-8		1	Analog 2 Mode	Unsigned-8	
				2	Pulse 1 Mode	Unsigned-8		2	Pulse 1 Mode	Unsigned-8	
				3	Pulse 2 Mode	Unsigned-8		3	Pulse 2 Mode	Unsigned-8	
236	Read RTC Time	R	-				10	0	RTC Year	Unsigned-8	0
								1	RTC Month	Unsigned-8	
								2	RTC Day	Unsigned-8	
								3	RTC Hour	Unsigned-8	
								4	RTC Minute	Unsigned-8	
								5	RTC Second	Unsigned-8	
								6-9	Operating Time	Unsigned-32	
237	Write RTC Time	W	6	0	RTC Year	Unsigned-8	6	0	RTC Year	Unsigned-8	0,2,3,4,5,7
				1	RTC Month	Unsigned-8		1	RTC Month	Unsigned-8	
				2	RTC Day	Unsigned-8		2	RTC Day	Unsigned-8	
				3	RTC Hour	Unsigned-8		3	RTC Hour	Unsigned-8	
				4	RTC Minute	Unsigned-8		4	RTC Minute	Unsigned-8	
				5	RTC Second	Unsigned-8		5	RTC Second	Unsigned-8	
238	Read LCD Password	R	-				9	0	LCD Password Set Mode	Unsigned-8	0
								1-4	LCD Password (User)	Unsigned-32	
								5-8	LCD Password (Master)	Unsigned-32	
239	Write LCD Password	W	9	0	LCD Password Set Mode	Unsigned-8	9	0	LCD Password Set Mode	Unsigned-8	0,2,3,1,5,7,32
				1-4	LCD Password (User)	Unsigned-32		1-4	LCD Password (User)	Unsigned-32	
				5-8	LCD Password (Master)	Unsigned-32		5-8	LCD Password (Master)	Unsigned-32	
240	Switch DSP Mode	C	1	0	DSP Mode	Unsigned-8	1	0	DSP Mode	Unsigned-8	0,2,5,32

10 Bell 202 command list

Command			Request Data				Response Data				Response Code
No.	Description	Type	Size	Byte	Name	Format	Size	Byte	Name	Format	
241	Read Display Settings	R	-				22	0	Display Mass Flow Priority	Unsigned-8	0
								1	Display Volume Flow Priority	Unsigned-8	
								2	Display Density Priority	Unsigned-8	
								3	Display Temperature Priority	Unsigned-8	
								4	Concentration Priority	Unsigned-8	
								5	Display Total #1 Count Priority	Unsigned-8	
								6	Display Total #2 Count Priority	Unsigned-8	
								7	Display Total #1 Flow Priority	Unsigned-8	
								8	Display Total #2 Flow Priority	Unsigned-8	
								9	Display Analog #1 Percent of Range	Unsigned-8	
								10	Display Analog #2 Percent of Range	Unsigned-8	
								11	Display Refresh Time	Unsigned-8	
								12	Display Font	Unsigned-8	
								13	Display Mass Flow Decimal Digits	Unsigned-8	
								14	Display Volume Flow Decimal Digits	Unsigned-8	
								15	Display Density Decimal Digits	Unsigned-8	
								16	Concentration Decimal Digits	Unsigned-8	
								17	Display Total #1 Flow Decimal Digits	Unsigned-8	
								18	Display Total #2 Flow Decimal Digits	Unsigned-8	
								19	Display Back Light	Unsigned-8	
								20	Display Telop Information	Unsigned-8	
								21	Display Contrast	Unsigned-8	

Command			Request Data				Response Data				Response Code
No.	Description	Type	Size	Byte	Name	Format	Size	Byte	Name	Format	
242	Write Display Settings	W	22	0	Display Mass Flow Priority	Unsigned-8	22	0	Display Mass Flow Priority	Unsigned-8	0,2,1,5,7,32
				1	Display Volume Flow Priority	Unsigned-8		1	Display Volume Flow Priority	Unsigned-8	
				2	Display Density Priority	Unsigned-8		2	Display Density Priority	Unsigned-8	
				3	Display Temperature Priority	Unsigned-8		3	Display Temperature Priority	Unsigned-8	
				4	Concentration Priority	Unsigned-8		4	Concentration Priority	Unsigned-8	
				5	Display Total #1 Count Priority	Unsigned-8		5	Display Total #1 Count Priority	Unsigned-8	
				6	Display Total #2 Count Priority	Unsigned-8		6	Display Total #2 Count Priority	Unsigned-8	
				7	Display Total #1 Flow Priority	Unsigned-8		7	Display Total #1 Flow Priority	Unsigned-8	
				8	Display Total #2 Flow Priority	Unsigned-8		8	Display Total #2 Flow Priority	Unsigned-8	
				9	Display Analog #1 Percent Of Range	Unsigned-8		9	Display Analog #1 Percent Of Range	Unsigned-8	
				10	Display Analog #2 Percent Of Range	Unsigned-8		10	Display Analog #2 Percent Of Range	Unsigned-8	
				11	Display Refresh Time	Unsigned-8		11	Display Refresh Time	Unsigned-8	
				12	Display Font	Unsigned-8		12	Display Font	Unsigned-8	
				13	Display Mass Flow Decimal Digits	Unsigned-8		13	Display Mass Flow Decimal Digits	Unsigned-8	
				14	Display Volume Flow Decimal Digits	Unsigned-8		14	Display Volume Flow Decimal Digits	Unsigned-8	
				15	Display Density Decimal Digits	Unsigned-8		15	Display Density Decimal Digits	Unsigned-8	
				16	Concentration Decimal Digits	Unsigned-8		16	Concentration Decimal Digits	Unsigned-8	
				17	Display Total #1 Flow Decimal Digits	Unsigned-8		17	Display Total #1 Flow Decimal Digits	Unsigned-8	
				18	Display Total #2 Flow Decimal Digits	Unsigned-8		18	Display Total #2 Flow Decimal Digits	Unsigned-8	
				19	Display Back Light	Unsigned-8		19	Display Back Light	Unsigned-8	
				20	Display Telop Information	Unsigned-8		20	Display Telop Information	Unsigned-8	
21	Display Contrast	Unsigned-8	21	Display Contrast	Unsigned-8						
243	Read Status For Display	R	-				14	0	Key Volume Set Mode	Unsigned-8	0
								1	Left Key Volume	Unsigned-8	
								2	Right Key Volume	Unsigned-8	
								3	Key Malfunction Prevention	Unsigned-8	
								4	Self-Diagnosis Status 1	Unsigned-8	
								5	Self-Diagnosis Status 2	Unsigned-8	
								6	Self-Diagnosis Status 3	Unsigned-8	
								7	Self-Diagnosis Status 4	Unsigned-8	
								8	Self-Diagnosis Status 5	Unsigned-8	
								9	Self-Diagnosis Status 6	Unsigned-8	
								10	Self-Diagnosis Status 7	Unsigned-8	
								11	Self-Diagnosis Status 8	Unsigned-8	
								12	Self-Diagnosis Status 9	Unsigned-8	
								13	Self-Diagnosis Remain Time	Unsigned-8	
								14	LCD Test Mode	Unsigned-8	
			15	LCD Display Wait	Unsigned-8						

10 Bell 202 command list

Command			Request Data				Response Data				Response Code
No.	Description	Type	Size	Byte	Name	Format	Size	Byte	Name	Format	
244	Write Key Volume	W	4	0	Key Volume Set Mode	Unsigned-8	4	0	Key Volume Set Mode	Unsigned-8	0,2,3,4,1,5,7,32
				1	Left Key Volume	Unsigned-8		1	Left Key Volume	Unsigned-8	
				2	Right Key Volume	Unsigned-8		2	Right Key Volume	Unsigned-8	
				3	Key Malfunction Prevention	Unsigned-8		3	Key Malfunction Prevention	Unsigned-8	
245	Read EEPROM Data	R	-				21	0-3	EEPROM Address	Unsigned-32	0,1,5,10
								4	EEPROM R/W Index	Unsigned-8	
								5-20	EEPROM R/W Data 0-15	Unsigned-8	
246	Write EEPROM Data	W	21	0-3	EEPROM Address	Unsigned-32	21	0-3	EEPROM Address	Unsigned-32	0,10,1,5,7,32
				4	EEPROM R/W Index	Unsigned-8		4	EEPROM R/W Index	Unsigned-8	
				5-20	EEPROM R/W Data 0-15	Unsigned-8		5-20	EEPROM R/W Data 0-15	Unsigned-8	
247	Read Key Volume Adjust Status	R	-				3	0	Key Volume Adjust Status	Unsigned-8	0
								1	Left Key Volume In Adjust	Unsigned-8	
								2	Right Key Volume In Adjust	Unsigned-8	
248	Write Key Volume In Adjust	W	3	0	Key Volume Adjust Status	Unsigned-8	3	0	Key Volume Adjust Status	Unsigned-8	0,2,1,5,32
				1	Left Key Volume In Adjust	Unsigned-8		1	Left Key Volume In Adjust	Unsigned-8	
				2	Right Key Volume In Adjust	Unsigned-8		2	Right Key Volume In Adjust	Unsigned-8	
249	Read Software Version	R	1	0	CPU Code	Unsigned-8	3	0	CPU Code	Unsigned-8	0,2,1,5,32
								1	CPU Major Version	Unsigned-8	
								2	CPU Minor Version	Unsigned-8	
250	Write Software Version	W	3	0	CPU Code	Unsigned-8	3	0	CPU Code	Unsigned-8	0,2,1,5,32
				1	CPU Major Version	Unsigned-8		1	CPU Major Version	Unsigned-8	
				2	CPU Minor Version	Unsigned-8		2	CPU Minor Version	Unsigned-8	
251	Perform 0 Degrees Celsius Calibration	C	3	0-2	Password	Unsigned-24	-				0,16,1,5,7,32
252	Perform 20 Degrees Celsius Calibration	C	3	0-2	Password	Unsigned-24	-				0,16,1,5,7,32
253	Perform Sensor Stability Check	C	3	0-2	Password	Unsigned-24	-				0,16,1,5,7,32

NOTE:

If you need the Bell 202 command list as an Excel file, please contact your nearest sales representative.

11 Maintenance

In the event an error occurs, an error message appears at the bottom of LCD display. Make sure of its nature. Sections 10.1 Error Messages and 10.2 Status Messages will assist you in identifying the cause of trouble and finding necessary corrective action. If the problem persists, or if you have any question, contact Anton Paar.

11.1 Error Messages

Error type	Status (Status display)	Description	Coping action	Indications in error			Influences on output in an error				Status Output	
				RED LED	GRN LED	Backlight (*)	Analog Output 1	Analog Output 2	Pulse Output 1	Pulse Output 2		Status Select
Saturated Alarm	Analog Output 1 Saturated (Ana. Out 1 SatUr)	Analog output 1 out of -10 to 110(%) range; failure to produce proper output.	Measurement is out of range. Adjust measurement such that measurement selected falls within [lower limit of analog output to upper limit value], or modify setting. (*6)				21.6mA	None	Unaffected		Per status select (*7)	
	Analog Output 2 Saturated (Ana. Out 2 SatUr)	Analog output 2 out of -10 to 110(%) range; failure to produce proper output.	Measurement is out of range. Adjust measurement such that measurement selected falls within [lower limit of analog output to upper limit value], or modify setting. (*6)				2.4mA	None	Unaffected		Per status select (*7)	
	Pulse Output 1 Saturated (Pis. Out 1 SatUr)	Pulse output 1 exceeds 11kHz; failure to produce proper output.	Instant flowrate selected exceeds full scale flowrate of pulse output. Lower instant flowrate for use or increase full scale flowrate setting. (*5)	Blink	ON	OFF	None	21.6mA	None	11kHz		Per status select (*7)
	Pulse Output 2 Saturated (Pis. Out 2 SatUr)	Pulse output 2 exceeds 11kHz; failure to produce proper output.	Instant flowrate selected exceeds full scale flowrate of pulse output. Lower instant flowrate for use or increase full scale flowrate setting. (*5)	Blink	ON	OFF	None	2.4mA	None	11kHz		Per status select (*7)
Sensor Failure	Drive Input Out of Range (Drive OutOfRange)	Drive frequency out of normal range; failure to make proper measurement.	A fault in drive oil connections is a possibility. Verify drive coil connections by self-diagnostics. (For details, see 9.6.2 Drive coil check.)									
	Scale Over (Scale Over)	Mass flowrate exceeds 110% of max allowable range; possible failure to make proper measurement.	Mass flowrate exceeds the specification. Use within the maximum allowable range.									
	Temperature Out of Range (Temp. OutOfRange)	Temperature out of normal range; failure to make proper measurement.	A fault in temperature sensor is a possibility. Verify temperature sensor connections by self-diagnostics. (For details, see 9.6.3 Transmitter check.)									
	Density Outside Limits (Density Outside)	Density measured out of normal range (0 to 51g/ml); failure to make proper measurement.	Bubble entrapment is a possibility. Check for bubble entrapment.									
	P.O. Sig Error (P.O. Sig Err)	Pickoff signal voltage out of normal range; failure to make proper measurement.	A fault in pickoff sensor is a possibility. Verify pickoff coil connections by self-diagnostics. (For details, see 9.6.3 Transmitter check.)	ON	OFF	ORG (*4)		Per error output Setting (*6)		Per error output Setting (*5)		Per status select (*7)
	Temperature Connect Error (Temp Connect Err)	A fault possible in temperature sensor wiring connections	A fault in temperature sensor is a possibility. Check temperature sensor connections.									
Transmitter Failure	P.O. Connect Error (P.O. Connect Err)	A fault possible in pickoff sensor wiring connections	A fault in pickoff coil connections. Check pickoff coil connections for condition.									
	Drive Coil Error	A fault possible in drive coil wiring connections	A fault in drive coil connections. Check drive coil connections. (This error does not show up in measurement. Upon error diction, be sure to verify drive coil connections by self-diagnostics.)									
Parameter Alarm	EEPROM Error (EEPROM Err)	An error in parameters; inactive operation	A fault in EEPROM is suspected. Contact the factory.	Blink (*2)	OFF	ORG (*4)		2.4mA		Stopped		OFF
	Data Update Error (Data Update Err)	A fault in internal data	A fault in transmitter is suspected. Contact the factory.	ON	OFF	ORG (*4)		Per error output setting (*3, 6)		Per error output setting (*3, 5)		Status Select (*7)
	Analog 1 Set Alarm (Ana. 1 Set Alm.)	Parameter setting of analog output 1 or analog output 2 comes under any of the following conditions - Upper limit < lower limit	Verify parameters and reconfigure to acceptable values. (*6)									
	Analog 2 Set Alarm (Ana. 2 Set Alm.)	- Upper limit or lower limit > max acceptable setting - Upper limit or lower limit < max acceptable setting H/L alarm parameter setting comes under any of the following conditions • High alarm < Low alarm • High alarm or low alarm > max acceptable setting • High alarm or low alarm < max acceptable setting	Verify parameters and reconfigure to acceptable values. (For details, see 9.16 H/L Alarm Functions.)	Blink	ON	OFF		Per error output setting (*6)		Per error output setting (*5)		Status Select (*7)
Calibration Failure	H/L Alarm Point Set Alarm (H/L pc.Set Alm.)		Wait until the fluid flow settles down to a steady state and retry zeroing.									
	Auto Zero Failed (Auto Zero Fail)	Auto zero offset (correction) is out of normal range.		Blink	OFF	OFF		Unaffected		Unaffected		Status Select (*7)
Slug Flow Alarm	Stays on for a preset duration (slug flow check) upon detention of entrapment		Air entrapment in the fluid is a possibility. Verify the fluid and line for conditions.	Blink	ON	OFF		Only flow output Clamped		Clamped		Status Select (*7)
	After expiration of slug flow check duration upon entrapment detection			Blink	ON	OFF		Flow output at '0'		Stopped		Status Select (*7)
Transmitter Alarm	Xmtr Temperature Alarm (Txr Temp Alm.)	Transmitter's internal temperature is unusual (above 80°)	High ambient temperature causes a rise in the transmitter's internal temperature, leading to shorten life of components. Take necessary step to lower ambient temperature.	Blink	ON	OFF		Continued		Continued		Status Select (*7)
	Switch Alarm (Switch Alm.)	Faulty operating switches	Faulty switch operation. Contact the factory.	OFF	ON	OFF		Continued		Continued		Status Select (*7)

NOTES:

- * 1: Even with the run indicator staying off, the white backlight comes on in response to switch operation when backlight is set in the "ON" or "sleep".
- * 2: In an alarm, the LED blinks at a faster rate (at intervals of 100ms) than in other alarms (at intervals of 250ms).
- * 3: Outputs can go uncontrolled under certain circumstances if the transmitter fails, however.
- * 4: For 5 minutes after occurrence of an alarm condition (or sleep duration of backlight setting), the ORG backlight comes on; after which it will blink on and off.
- * 5: For details, see 9.12 Pulse Output Function.
- * 6: For details, see 9.13 Analog Output Function.
- * 7: For details, see 9.14 Status Output Function.

11.2 List of Status Messages

Status type	Status (Status display)	Description	Indications in error			Influences on output in an error				
			RED LED	GRN LED	Backlight (*1)	Analog Output 1	Analog Output 2	Pulse Output 1	Pulse Output 2	Status Output
Fixed Output	Analog Output 1 Fixed (Ana. Out 1 Fix)	Analog output 1 fixed is active (*2)				Fixed output	Unaffected	Unaffected	Unaffected	Unaffected
	Analog Output 2 Fixed (Ana. Out 2 Fix)	Analog output 2 fixed is active (*2)				Unaffected	Fixed output	Unaffected	Unaffected	Unaffected
	Pulse Output 1 Fixed (Pls. Out 1 Fix)	Pulse output 1 fixed is active (*2)	OFF	Blink	OFF	Unaffected	Unaffected	Fixed output	Unaffected	Unaffected
	Pulse Output 2 Fixed (Pls. Out 2 Fix)	Pulse output 2 fixed is active (*2)				Unaffected	Unaffected	Unaffected	Fixed output	Unaffected
	Status Output Fixed (Status Out Fix)	Status output fixed is active (*2)				Unaffected	Unaffected	Unaffected	Unaffected	Fixed output
	0% Sig Lock (0% Sig Lock)	With a status input, 0% signal lock is active. (*2) (Analog output clamped at 4mA with no pulse output.)				4mA	4mA	Stopped	Stopped	Unaffected
Calibration in Progress	Calibration in Progress (Cal. in Progress)	Auto zero in progress	OFF	Blink	OFF while ORG indicator blinks at operation startup and shutoff. OFF during the test	Unaffected	Unaffected	Unaffected	Unaffected	Unaffected
H/L Alarm	H/L Alarm Triggered (H/L Alm. Trig.)	H/L alarm occurred and is active. (For details, see 9.16 High/Low Alarm Function.)	OFF	Blink	OFF	Unaffected	Unaffected	Unaffected	Unaffected	Unaffected
Drive Output Alarm	Drive Out Alarm (Drive Out Alarm)	Drive output is exceeding the threshold.	OFF	Blink	OFF	Unaffected	Unaffected	Unaffected	Unaffected	Unaffected
Concentration alarm	Concentration out of range (Conc OutOfRange)	Concentration, density, and temperature are out range	Blinking	Turned on	Turned off	Unaffected	Unaffected	Unaffected	Unaffected	Unaffected
	Concentration set alarm (Concent set ALm.)	Concentration, alarm range is higher than the sensor limit value	Blinking	Turned on	Turned off	Unaffected	Unaffected	Unaffected	Unaffected	Unaffected
Test	Self-Diagnosis (Self-Diag)	Self-diagnosis in progress	OFF	Blink	OFF	0%	0%	Stopped	Stopped	Unaffected
	Installation (Installation)	Pipeline vibration check in progress	OFF	Blink	OFF	0%	0%	Stopped	Stopped	Unaffected
	Maintenance Test (Maintenance Test)	Maintenance in progress	OFF	Blink	OFF	Unaffected (Set output during simulated output)	Unaffected (Set output during simulated output)	Unaffected (Set output during simulated output)	Unaffected (Set output during simulated output)	Unaffected (Set output during simulated output)
Transmitter Operation	Key Protect (Key protect)	If parameter change is made by switch operation while the Key Protect was ON. (If key operation is required, reconfiguration is needed.)	OFF	ON	OFF	Unaffected	Unaffected	Unaffected	Unaffected	Unaffected
	Write protect.	When the target parameter is changed or the operation for executing the target function is carried out in Write Protect mode.	OFF	ON	OFF	Unaffected	Unaffected	Unaffected	Unaffected	Unaffected
	Transmitter Operating-Time Over (Time Over LCD)	When the number of run hours has exceeded 100,000 hours, it could lead to component failure or degradation. We suggest transmitter replacement. (You can cancel indicator ○. See 9.2.7 Transition chart (6) [No. 4-3].)	OFF	ON	OFF	Unaffected	Unaffected	Unaffected	Unaffected	Unaffected
Transmitter Operation	Transmitter Warm up (WARMUP 20)	Warmup in progress (Stays on for 20 minutes upon power on. Countdown value decrements at one (1) minute intervals.)	OFF	ON	OFF	Unaffected	Unaffected	Unaffected	Unaffected	Unaffected
	Power OK?	Poor power supply condition is a possibility. (A short duration power cycling has occurred a couple of times.) While there is no problem in continuation of operation, we suggest to run a check for condition of power supply. This message goes out automatically in 20 minutes.	OFF	ON	OFF	Unaffected	Unaffected	Unaffected	Unaffected	Unaffected

NOTES:

- * 1: Even with the run indicator staying off, the white backlight comes on in response to switch operation if backlight is set in the sleep mode.
- * 2: Simulated output is available irrespective of the state of alarm. (Certain types of error disables output, however.)

11.3 Replacement Parts

We recommend to keep replacement spare parts to reduce downtime. Replacement parts can be purchased through Anton Paar representative in your area or Anton Paar Customer Service Department. Please contact us with the flowmeter model, part name, product number, and quantity at the time of order.

Interconnect cable (Teflon or PVC): Quantity 1

Replacement of parts such as O-rings and sheet packing for transmitter and terminal box

O-rings and gaskets are used as sealing components with limited service life. Although the exact service life depends on the operating environment, periodic replacement is recommended. Recommended replacement period: 5 to 8 years after the delivery

 **CAUTION:**

- 1. Whenever you open or disassemble the instrument, inspect the O-rings and gaskets. Replace the deteriorated parts.**
- 2. To ensure the soundness, periodic re-torquing of the corresponding parts is recommended.**

Corresponding parts:

- Transmitter: O-ring between display lid (front) - body
- Transmitter: O-ring between terminal box lid (rear) - body
- Transmitter: Sheet packing between side lid - body
- Transmitter: O-ring between adopter - body (Integral type only)
- Transmitter: O-ring on sensor unit (Integral type only)
- O-ring between terminal box - lid (Separate type only)
- Cable gland: rubber seal and O-ring

Please contact Anton Paar sales office when replacement is necessary.

12 Regarding EHEDG Certification

L-Cor 6000 (EHEDG Specifications) has been certified by European Hygienic Engineering & Design Group.

Certification Type: TYPE EL CLASS

Acceptable Model: AS025, AS040, AS050

Process Connection: Tri-clamp ISO 2852

It is recommended to refer EHEDG Document Number 8 [Design Criteria for Sanitary Equipment/ Device] for details.

Comply strictly with your service conditions below in case of EHEDG Specifications.

(1) Mounting Orientation

- Install this equipment vertically in the line so as to enable self-drain.
- In case the electric conduit faces upward, make sure to prepare a countermeasure to rainwater from intruding inside.

(2) Important Point at CIP Washing

- Use wash solution at flow velocity of 1.5m/s min.

(3) Process Connection and Seal

- Conform to EHEDG Document.
Refer to EHEDG Position Paper "Pipe Coupling and Process Connections" (current version).

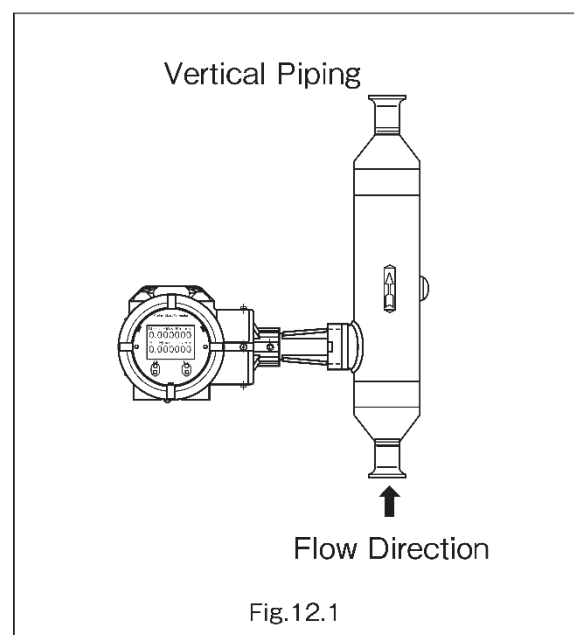

13.1.2 AU100 to AU15H

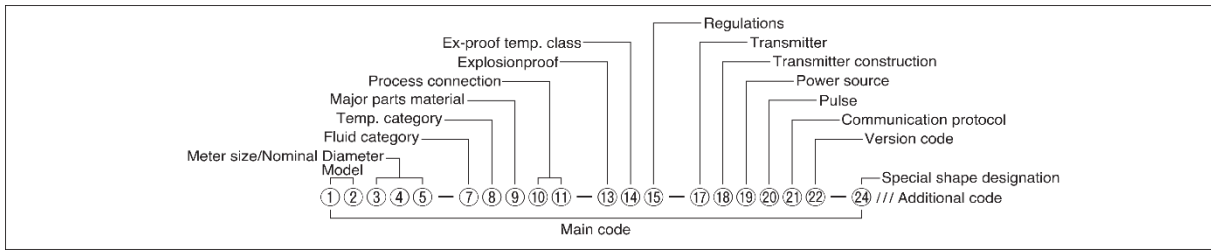

Main Code (AU100 to AU15H)

+ : Compatible, - : Not applicable

①	②	Model			AU100, AU150, AU15H	L-Cor 8100: AU100, AU150	L-Cor 8200: AU100, AU150, AU150H
A	U	L-Cor 8XXX					
③	④	⑤	Meter Size/Nominal Diameter				
			ASME B16.5 Flange	EN 1092-1 Flange			
1	0	0	4"	DN100			
1	5	0	6"	DN150			
1	5	H	6"	DN150			
⑥	-						
⑦	Fluid						
L	Liquid			+	+	+	
⑧	Temperature *1						
2	-200°C to 200°C (L-Cor 8000)			+	-	-	
3	-40°C to 350°C (L-Cor 8100)			-	+	-	
4	-200°C to 40°C (L-Cor 8200)			-	-	+	
⑨	Wetted parts						
S	SUS316L			+	+	+	
⑩	⑪	Process connection					
A	1	ASME B16.5 Class 150			+	+	+
A	3	ASME B16.5 Class 300			+	+	+
A	6	ASME B16.5 Class 600			+	+	+
D	4	EN 1092-1 PN40			+	+	+

⑫	-
⑬	Explosion-proof
0	Non-explosion-proof
2	ATEX, IECEx
4	CSA (C-US)
7	NEPSI *2
⑭	Ex-proof temperature class
0	Non-explosion-proof
1	T1
2	T2
3	T3
4	T4
5	T5
⑮	Regulations
0	Standard
K	CRN + 3.1 Material test certificate *3
F	3.1 Material test certificate
B	PED (Category II) *4
⑯	-
⑰	Transmitter *5
1	PA0K (Standard)
3	Rackmount
⑱	Transmitter construction
1	Integrated
2	Separated
⑲	Power source
1	20 to 30 VDC
⑳	Pulse
0	When "2, 3" are chosen for "21 Communication"
B	Voltage
G	Open drain (Standard)
㉑	Communication
1	Bell 202
2	Fieldbus
3	Profibus PA
4	Modbus (RS-485)
㉒	Version Code
B	Version code: B
㉓	-
㉔	Special shape designation
0	Standard

*1: Explosion-proof specifications are restricted depending on the temp. class.

*2: "2, 3" for "Communication ㉑" are not applicable.

*3: CRN is applicable only to CSA explosion-proof and ASME flange models.

*4: When selecting "B" for "Regulations ⑮" following limitations apply: Code ⑩⑪ are only to A1, A3, A6, D1, DB, D3 and D4.

*5: Applicable specifications differ with the rack-mount transmitter.

13.2 L-Cor 6000

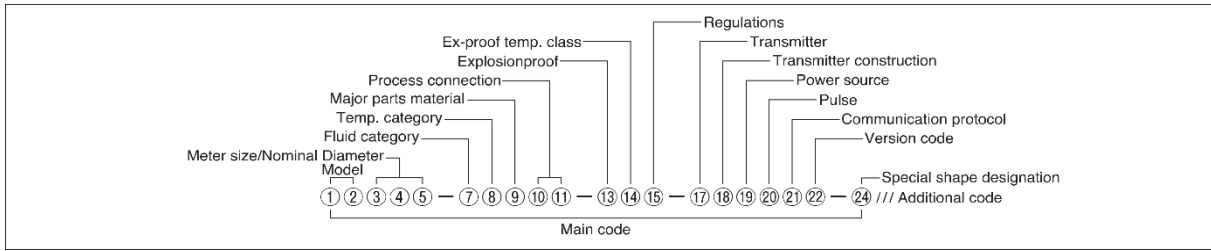

Main Code

+ : Compatible, - : Not applicable

①	②	Model	
A	S	L-Cor 6000	
③	④	⑤	Meter Size/Nominal Diameter
		ASME B16.5 Flange	
		Tri-clamp ISO 2852	
0	1	0	1/2"
0	1	5	1/2"
0	2	5	1"
0	4	0	1 1/2"
0	5	0	2"
R	5	0	3"
⑥	-		
⑦	Density range		
1	0.5 to 1.0 g/cm ³		
2	0.7 to 1.3 g/cm ³		
3	1.0 to 1.5 g/cm ³		
⑧	Temperature *1		
1	-40°C to 130°C		
⑨	Wetted parts		
T	SB338 Grade-9 + TB480H (Titan alloy)		
⑩	⑪	Process connection	
A	1	ASME B16.5 Class 150	
H	5	Tri-clamp ISO 2852	

⑫	-	
⑬	Explosion-proof *2	
0	Non-explosion-proof	
2	ATEX, IECEx	
4	CSA (C-US)	
7	NEPSI *3	
⑭	Ex-proof temperature class	
0	Non-explosion-proof	
3	T3	
4	T4	
⑮	Regulations	
0	Standard	
E	EHEDG *4	
F	3.1 Material test certificate	
B	PED (Category II)	
⑯	-	
⑰	Transmitter *5	
1	PAOK (Standard)	
3	Rackmount	
⑱	Transmitter construction *6	
1	Integrated	
2	Separated	
⑲	Power source	
1	20 to 30 VDC	
⑳	Pulse	
0	When "2, 3" are chosen for "21 Communication"	
B	Voltage	
G	Open drain (Standard)	
㉑	Communication	
1	Bell 202	
2	Fieldbus	
3	Profibus PA	
4	Modbus (RS-485)	
㉒	Version Code	
B	Version code: B	
㉓	-	
㉔	Special shape designation	
0	Standard	

*1: Explosion-proof specifications are restricted based on temperature class.

*2: For ASR50, applicable explosion-proof specifications are ATEX, and IECEx only.

*3: "2, 3" for "Communication ㉑" are not available.

*4: Process connections for AS025, AS040, and AS050 only apply to ISO ferrule.

*5: Applicable specifications differ with the rack-mount transmitter.

*6: If temperature of the fluid exceeds 80°C for explosion-proof types, only "Separately mounted" model is available for the transmitter construction.

In case of non-explosion-proof, Integrally mounted model can be used up to 130°C by restricting the transmitter ambient temp. to 45°C at maximum.

When "3" is chosen for "Transmitter construction ⑱" following limitations apply:

- Code ⑧ Only "Standard" available
- Code ⑰ Only "Rack-mount transmitter" available

13.3 L-Cor 4000

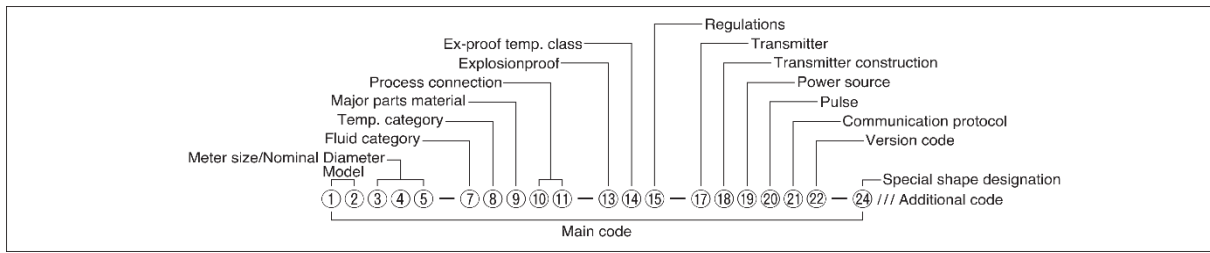

Main Code

+ : Compatible, - : Not applicable

①	②	Model	
A	B	L-Cor 4000	
③	④	⑤	Meter Size/Nominal Diameter
			ASME B16.5 Flange
0	0	6	1/2"
0	1	0	1/2"
0	1	5	1/2"
0	2	5	1"
0	4	0	1 1/2"
0	5	0	2"
			Tri-clamp ISO 2852
⑥	-		
⑦	Density range		
L	Liquid		
⑧	Temperature	*1	
1	-40°C to 130°C		
⑨	Wetted parts		
S	SUS316L		
⑩	⑪	Process connection	
A	1	ASME B16.5 Class 150	
A	3	ASME B16.5 Class 300	
A	6	ASME B16.5 Class 600	
H	S	Tri-clamp ISO 2852	

⑫	-
⑬	Explosion-proof
0	Non-explosion-proof
2	ATEX, IECEx
4	CSA (C-US)
7	NEPSI
	*2
⑭	Ex-proof temperature class
0	Non-explosion-proof
3	T3
4	T4
⑮	Regulations
0	Standard
K	CRN + 3.1 Material test certificate
F	3.1 Material test certificate
B	PED (Category II)
	*3
⑯	Transmitter
	*4
1	PAOK (Standard)
3	Rackmount
⑰	Transmitter construction
	*5
1	Integrated
2	Separated
⑱	Power source
1	20 to 30 VDC
⑲	Pulse
0	When "2, 3" are chosen for "21 Communication"
B	Voltage
G	Open drain (Standard)
㉑	Communication
1	Bell 202
2	Fieldbus
3	Profibus PA
4	Modbus (RS-485)
㉒	Version Code
B	Version code: B
㉓	Special shape designation
0	Standard

- *1: Explosion-proof specifications are restricted based on temperature class.
- *2: "2, 3" for "Communication ㉑" are in preparation and is not available yet.
- *3: CRN is applicable only to CSA explosion-proof and ASME flange models.
- *4: Applicable specifications differ with the rack-mount transmitter.
- *5: If temperature of the fluid exceeds 80°C for explosion-proof types, only "Separately mounted" model is available for the transmitter construction. In case of non-explosion-proof, Integrally mounted model can be used up to 130°C by restricting the transmitter ambient temp. to 45°C at maximum. When "3" is chosen for "Transmitter construction ⑰" following limitations apply:
 - Code ⑧ Only "Standard" available
 - Code ⑰ Only "Rack-mount transmitter" available

14 KC Mark

Registration No. R-R-OVJ-PA0K-A
MODEL: PA0K-A, PA0K-D
Equipment Class: Class A for Office Use

사용자안내문

이 기기는 업무용 환경에서 사용할 목적으로 적합성평가를 받은 기기로서
가정용 환경에서 사용하는 경우 전파간섭의 우려가 있습니다.

15 Document Numbers

Document Number	Date	Comment
XDPIB048EN-A	November 2023	First release
XDPIB048EN-B	April 2024	Minor adjustments
XDPIB048EN-C	October 2024	Adding HAS Dimensions

The image features a solid red background. At the bottom, there is a white grid pattern that curves upwards from the left and right sides, meeting in the center. The grid consists of thin white lines forming a mesh. In the lower center of the image, the website address www.anton-paar.com is written in white text.

www.anton-paar.com